



DISCOVERY 4

OWNER'S HANDBOOK

Publication Part No. LRL 10 02 53 121

ABOUT THIS HANDBOOK

Please take the time to study all of the owner/operator literature supplied with your vehicle as soon as possible.

IMPORTANT

The information contained in this handbook covers all vehicle derivatives and optional equipment, some of which may not be fitted to your vehicle. Due to printing cycles, this handbook may include descriptions of options before they become generally available.

The vehicle options, hardware and software, are designed for the market in which the vehicle is intended for sale. If the vehicle is to be used in another geographical area, it may need modifications to suit local requirements. Land Rover is not responsible for the cost of any modifications.

The information contained in this publication was correct when it went to print. Subsequent vehicle design changes may result in a supplement being added to the literature pack. Updates can also be viewed on the Land Rover internet site at; www.ownerinfo.landrover.com.

In the interest of development, the right is reserved to change specifications, design or equipment at any time without notice and without incurring any obligations. This publication, or part thereof, may not be reproduced nor translated without our approval. Errors and omissions excepted.

SYMBOLS USED IN THIS HANDBOOK



Safety warnings indicate either a procedure which must be followed precisely, or information that should be considered with great care, in order to avoid the possibility of personal injury.



Cautions indicate either a procedure which must be followed precisely, or information that should be considered with great care, in order to avoid the possibility of damage to your vehicle.



This recycling symbol identifies those items that must be disposed of safely in order to prevent unnecessary damage to the environment.



This symbol identifies those features that can be adjusted, disabled or enabled by your Dealer/Authorised Repairer.

©Land Rover 2011.

All rights reserved. Published by **Land Rover Technical Communications**.

| | | | |
|--------------------------------------|-----|--------------------------------|-----|
| Introduction..... | 2 | Audio/video overview | 119 |
| Entering the vehicle | 5 | Radio..... | 123 |
| Exiting the vehicle..... | 11 | DAB radio | 125 |
| Front seats..... | 14 | CD player..... | 127 |
| Rear seats | 18 | Portable media | 130 |
| Head restraints | 22 | Television | 136 |
| Steering wheel..... | 24 | Video media player..... | 138 |
| Occupant safety..... | 25 | Rear seat entertainment | 140 |
| Exterior lights | 38 | Voice control | 144 |
| Interior lights..... | 42 | Telephone..... | 147 |
| Wipers and washers | 43 | Navigation system..... | 153 |
| Windows | 45 | Tyre repair kit | 165 |
| Mirrors | 47 | Fuel and refuelling | 170 |
| Garage door opener..... | 49 | Maintenance | 176 |
| Instrument panel | 52 | Fluid level checks | 193 |
| Warning lamps | 54 | Technical specifications | 200 |
| Message centre | 58 | Vehicle battery..... | 207 |
| Heating and ventilation | 60 | Tyres | 211 |
| Storage compartments..... | 65 | Fuses..... | 214 |
| Load carrying | 68 | Wheel changing..... | 219 |
| Towing | 70 | Vehicle recovery | 228 |
| Starting the engine | 78 | After a collision | 231 |
| Gearbox..... | 81 | Vehicle identification | 232 |
| Stability control | 85 | Type approval..... | 233 |
| Air suspension..... | 86 | Controls overview..... | 264 |
| Brakes | 89 | | |
| Tyre pressure monitoring system...92 | | | |
| Parking aids..... | 94 | | |
| Cruise control..... | 96 | | |
| Camera systems..... | 97 | | |
| Terrain response | 99 | | |
| Hill descent control (HDC)..... | 102 | | |
| Standard audio system..... | 104 | | |
| Touch screen..... | 115 | | |

UNLOCKING THE VEHICLE

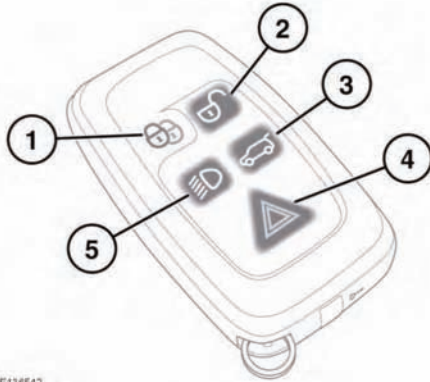

E136542



To prevent accidental operation, never leave the Smart Key in the vehicle if children or animals are also left in the vehicle.

Note: There are two designs of Smart Key, refer to the information which is relevant to the design of Smart Key supplied with the vehicle.

Note: The operational range of the Smart Key will vary considerably depending on atmospheric conditions and interference from other transmitting devices.

Note: If any door or the tailgate is unlocked 10 times within a short period, the latch is disabled for approximately one minute.

The vehicle is supplied with 2 Smart Keys. The Smart Keys act as remote controls for the locking and alarm system, and allow the vehicle to be locked, unlocked and driven without the use of a conventional key. See **8, KEYLESS ENTRY, 12, KEYLESS LOCKING** and **78, STARTING A PETROL ENGINE**.

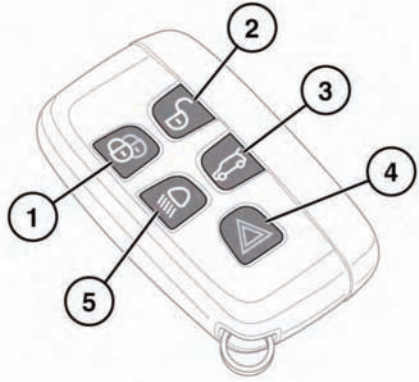

1. Lock:

- Press once to single lock the vehicle. All doors and the tailgate will lock (but can still be unlocked from inside) and the perimeter alarm will arm. See **11, SINGLE LOCKING**.
- Press twice (within 3 seconds) to double lock the vehicle. All doors and the tailgate will lock (and cannot be unlocked from inside the vehicle) and both the perimeter alarm and interior space protection will be armed. See **11, DOUBLE LOCKING**. See also **12, GLOBAL CLOSING**.

2. Your vehicle can be unlocked using either Single or Multi-point entry.

- Single point entry. The first press unlocks the driver's door and enables the other doors to be opened from the inside. The hazard warning lamps will flash twice to indicate that the vehicle is unlocked and the alarm has been disarmed. A second press unlocks the passenger doors and the luggage compartment.

Entering the vehicle

- Multi point entry. Press briefly to unlock all the doors and luggage compartment and to disarm the alarm. The hazard warning lamps will flash twice to indicate that the vehicle is unlocked and the alarm has been disarmed.

To change from Single to Multi-point entry (or vice versa), press both the lock and unlock buttons simultaneously for three seconds. The hazard warning lamps will flash twice to confirm the change.

Note: *If a door or the tailgate are not opened within 1 minute of unlocking the vehicle, doors will lock again automatically.*

3. Tailgate release:

- Press briefly to release the tailgate. The vehicle security system will remain active while the tailgate is open, but intrusion and inclination sensing systems will be disabled.

On closing of the tailgate, the hazard warning lamps will flash after a few seconds to confirm the full alarm system has been reactivated (if previously armed). Also see **9**,

OPENING THE TAILGATE.

4. Panic alarm:

- Press and hold for 3 seconds (or press 3 times within 3 seconds) to activate the horn and the hazard lamps.

Note: *The horn and hazard lamps will switch off automatically after 2 minutes and 45 seconds.*

- Once active for more than 5 seconds, the alarm can be cancelled by pressing the button and holding for 3 seconds (or pressing 3 times within 3 seconds).

- The emergency alarm will also be cancelled if a valid smart key is present when the START/STOP button is pressed.

5. Approach lighting:

- When approaching the vehicle during darkness, press to switch on the approach illumination. Press again to turn the approach lamps off.
- The approach illumination period set at the factory is 30 seconds. This delay period may be configured to provide illumination lasting between 0 and 180 seconds.

Note: *A replacement Smart Key can only be obtained from your Dealer/Authorised Repairer. The Dealer/Authorised Repairer will require proof of ownership.*

Notify your Dealer/Authorised Repairer immediately if a Smart Key is lost or stolen.

Note: *The fuel filler flap can only be opened when the vehicle is unlocked.*

EMERGENCY KEY

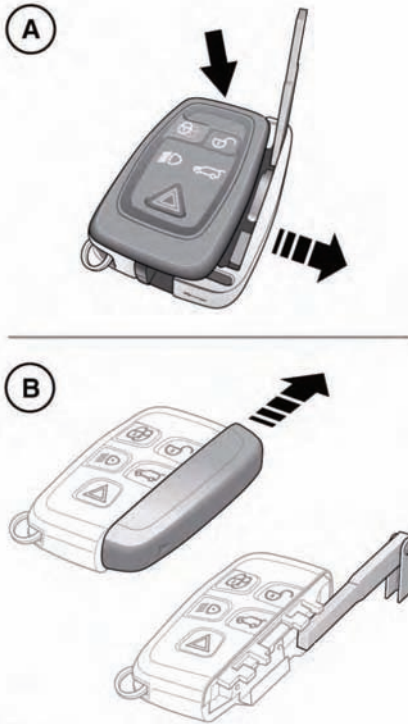

E136543

Note: There are two designs of Smart Key, refer to the information which is relevant to the design of Smart Key supplied with the vehicle.

- A. Press emergency key release button and pull out side cover to release the key.
- B. Slide and remove cover to expose the emergency key.

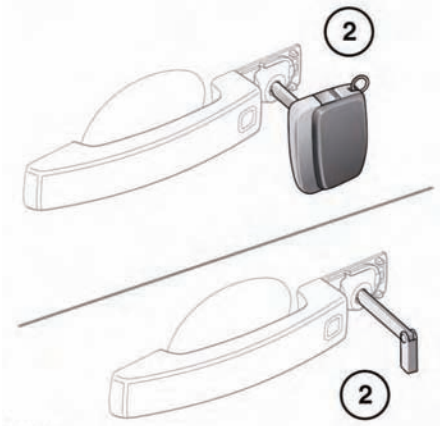
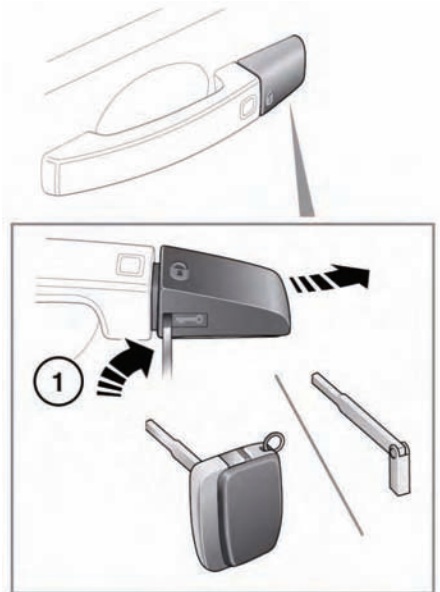

E136544

1. Insert the key blade into the slot at the base of the door lock cover and gently lever the key blade upwards.
Carefully twist the key blade, to lever the cover off the retaining clips.

Entering the vehicle

2. Insert the key blade into the exposed lock to operate.

To lock: Ensure all doors are closed, then turn the key blade towards the front of the vehicle and release. This will lock the doors but will not arm the alarm.

To unlock: Turn the key blade towards the rear of the vehicle and release. If the security system is disarmed, all doors and the tailgate will be unlocked. If the security system is armed, only the driver's door will unlock.

If the vehicle is unlocked using the emergency key blade with the security system armed, the alarm will sound when the door is unlocked. The alarm will continue to sound until the remote key fob is positioned correctly. See **79, IF THE ENGINE FAILS TO START.**

GLOBAL OPENING

Press and hold the unlock button for 3 seconds to unlock the vehicle and open all of the windows.

To cancel global opening, press any of the buttons on the smart key or operate the driver's window switch. To stop a particular window opening, operate the relevant window switch.

This feature can be enabled/disabled via the **Vehicle set-up** menu (see **52, INTERACTIVE CONTROLS**).

KEYLESS ENTRY



Any person fitted with an implanted medical device should ensure that the device is kept at a distance of at least 22 cm (8.7 inches) away from any transmitter mounted in the vehicle. This is to avoid any possibility of interference between the system and device. For information concerning the locations of the security system transmitters, see 206, REMOTE KEY FOB TRANSMITTER LOCATIONS.



If a remote control is lost, a replacement can be obtained and programmed to the vehicle by a Land Rover Dealer/Authorised Repairer. Notify a Land Rover Dealer/Authorised Repairer as soon as a remote control is lost or stolen and have the remaining remote control(s) reprogrammed.



The Smart Key may not be detected if it is placed within a metal container or if it is shielded by a device with a back-lit LCD screen, such as a smart phone, laptop (including laptop bag), games console etc. Keep the Smart Key clear of such devices when attempting Keyless entry or Keyless starting.

Keyless entry allows the vehicle to be unlocked or disarmed, simply by operating any door handle. For keyless entry to activate, the Smart Key must be within 1.0 m (3 feet) of the door handle when it is operated. When keyless entry operates, the alarm will be disarmed and the doors unlocked according to the current security setting (single or multipoint entry). The hazard warning lamps will flash twice as confirmation (in some markets an audible warning will sound twice).

Note: The Smart Key needs only to be on the driver's person or in a non-metallic bag or briefcase. It does not need to be exposed or handled.

Note: If single point entry is the current security setting, and a door other than the driver's door is opened first, the vehicle will behave as if multi-point entry is active (i.e. all doors will unlock).

DRIVE-AWAY LOCKING

Drive-away locking automatically locks all the doors when the vehicle is in motion. This feature can be enabled/disabled via the **Vehicle set-up** menu, see **52, INTERACTIVE CONTROLS**.

Note: Pressing the lock or unlock button on the Smart Key will override drive-away locking for the current journey.

OPENING THE TAILGATE

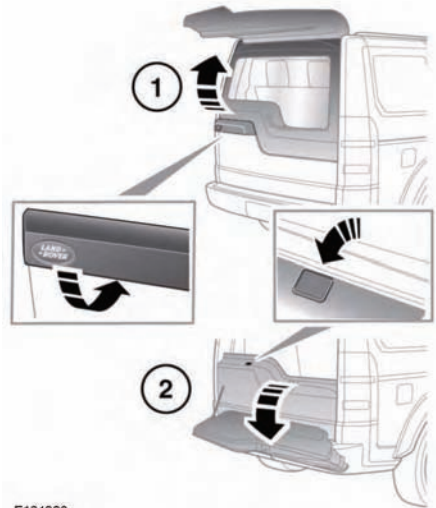

Upper tailgate: Unlock the vehicle and press the touchpad (1) on the underside of the exterior handle. Pull the tailgate upwards to open.

Lower tailgate: With the upper tailgate open, press the touchpad on the lower tailgate waist moulding (2). Lower the tailgate to open.

REMOTE KEY FOB BATTERY REPLACEMENT

Note: There are two designs of Smart Key, refer to the information which is relevant to the design of Smart Key supplied with the vehicle.

When the battery needs renewing, there will be a significant decrease in the effective range and the message **SMART KEY BATTERY LOW** will be displayed in the message centre.

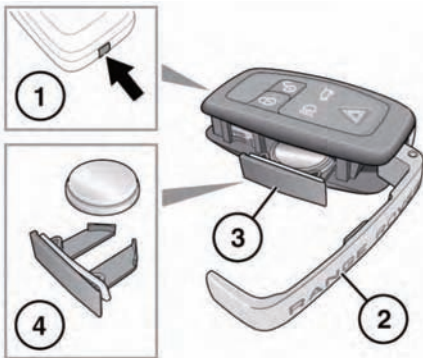

E134815

To replace the battery:

1. Press and hold the release button.
2. Open the side cover.
3. Remove the battery drawer and remove the battery.
4. Fit a new CR2032 type battery (available from your Dealer/Authorised Repairer), with the positive (+) side upwards.

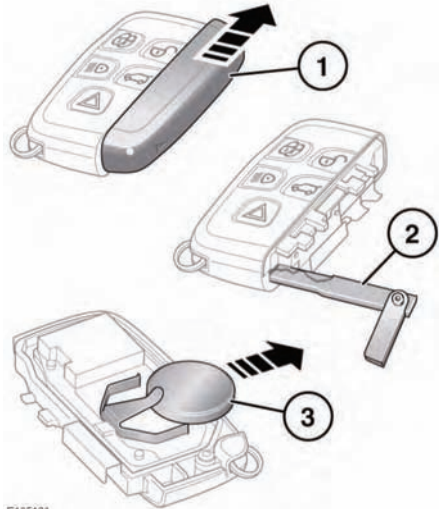

E135421

To replace the battery:

1. Slide the cover in the direction of the arrow until a click is heard. Remove the cover.
2. Use the emergency key blade to separate the Smart key body.
3. Fit a new CR2032 type battery (available from your Dealer/Authorised Repairer), with the positive (+) side upwards.

Note: Avoid touching the new battery, as moisture/oil from fingers can reduce battery life and corrode the contacts.

Refit the parts in reverse order, ensuring that they click securely into place.



Battery disposal: Used batteries must be disposed of correctly, as they contain harmful substances. Seek advice on disposal from your Dealer/Authorised Repairer and/or your local authority.

SINGLE LOCKING



Before exiting the vehicle, always ensure that the gear selector is in the Park (P) position, the engine is turned off, the parking brake is applied and the Smart Key is removed from the vehicle.

Single locking secures the vehicle and prevents the doors from being opened from outside. The doors may still be unlocked and opened from inside the vehicle. In this state, only the perimeter alarm is activated. See **11, PERIMETER ALARM**.

DOUBLE LOCKING



Before exiting the vehicle, always ensure that the gear selector is in the Park (P) position, the engine is turned off, the parking brake is applied and the Smart Key is removed from the vehicle.



Never double lock the vehicle with people, children, or pets inside. In the event of an emergency they would be unable to escape and the emergency services would be unable to release them quickly.

Double locking secures the vehicle and prevents the doors being opened from inside or outside of the vehicle. The doors cannot be unlocked or opened from inside the vehicle when double locked.

This provides additional security if the vehicle is left unattended. The vehicle cannot be opened by breaking a window and operating the door locks from inside.

Additionally, double locking also activates the full alarm system. See **11, FULL ALARM**.

PERIMETER ALARM

Once the perimeter alarm is armed, the alarm system will sound if:

- The bonnet, tailgate or a door are opened.
- The vehicle battery is disconnected.
- An attempt is made to disconnect the alarm siren.

Note: *This setting should be used in circumstances such as travelling on a ferry, when pets are to be left in the vehicle, or if a window must be left open etc.*

FULL ALARM

When the full alarm is activated, the alarm system will sound if:

- The bonnet, tailgate or a door are opened.
- Movement is detected within the vehicle interior.
- A window, front or rear windscreen or sunroof glass are broken.
- The vehicle is raised or tilted.
- The vehicle battery is disconnected.
- An attempt is made to disconnect the alarm system.

Note: *In this state, an open window or sunroof will cause the alarm to sound due to the movement of air currents. For this reason, ensure all windows and the sunroof are fully closed before double locking the vehicle.*

INTERIOR PROTECTION

The interior protection feature of the full alarm system may be temporarily disabled via the **Vehicle set-up** menu (see **52, INTERACTIVE CONTROLS**).

Note: *Once enabled, this setting will activate the next time the vehicle is double locked with the Smart Key.*

Exiting the vehicle

GLOBAL CLOSING

 **Ensure that no children, pets, or obstructions are in any open aperture before operating global closing. Safety mechanisms are in place to prevent serious injury, however injuries can still occur.**

Press and hold the lock button for 3 seconds. The vehicle will single lock and the full alarm will be activated immediately. After 3 seconds any open windows will be closed. This feature can be enabled/disabled via the **Vehicle set-up** menu, see **52, INTERACTIVE CONTROLS**.

DOOR LOCK AND RELEASE LEVERS

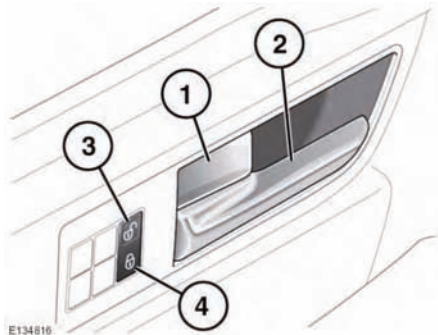

From inside the vehicle, all the doors can be locked by pressing either the driver or passenger lock lever (1).

Each rear door can be individually locked by pressing the appropriate locking lever.

To unlock and open a front door, pull the door handle (2). To unlock and open a rear door, first operate the lock lever, then pull the door handle.

Master lock/unlock buttons: To lock (4) or unlock (3) the vehicle press the respective button on the door.

Note: The master unlock button is inhibited when the vehicle is locked with the Smart Key.

MISLOCK

When attempting to lock the vehicle, if one or more of the doors, the bonnet or the tailgate are not fully closed, the vehicle will fail to lock and the horn will emit two tones. The vehicle will not fully lock until all doors, the bonnet and the tailgate are completely closed.

KEYLESS LOCKING

 **Never double lock the vehicle with people, children or pets inside. In the event of an emergency they would be unable to escape, and the emergency services would be unable to release them quickly.**

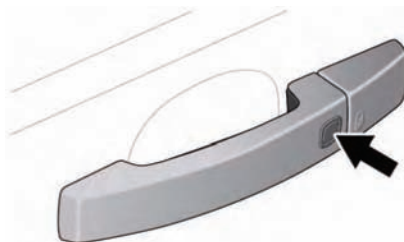

The vehicle will not lock automatically.

- To single lock the vehicle press the keyless locking button (arrowed) on the door handle once. The hazard warning lamps will flash once to confirm. In some markets an audible warning will sound.
- To double lock the vehicle, press the keyless locking button (arrowed) twice within 3 seconds. The hazard warning lamps will flash twice to confirm (with a long second flash). In some markets a double audible warning will sound.

Note: Keyless locking will only activate if the Smart Key is detected outside the vehicle. If no Smart Key is present when the button is pressed, two warning tones will sound.

To initiate global window closing, press and hold the keyless locking button for 3 seconds. This will also lock the vehicle and activate the alarm.

Note: *The windows will close only while the button is depressed. To fully secure the vehicle, continue to depress the button until all windows are fully closed.*

DEACTIVATING THE ALARM WHEN TRIGGERED

If the alarm has been triggered it can be deactivated by pressing the Smart Key unlock button, or by positioning the Smart Key underneath the steering column, see **79, IF THE ENGINE FAILS TO START**.

Front seats

MANUAL SEATS

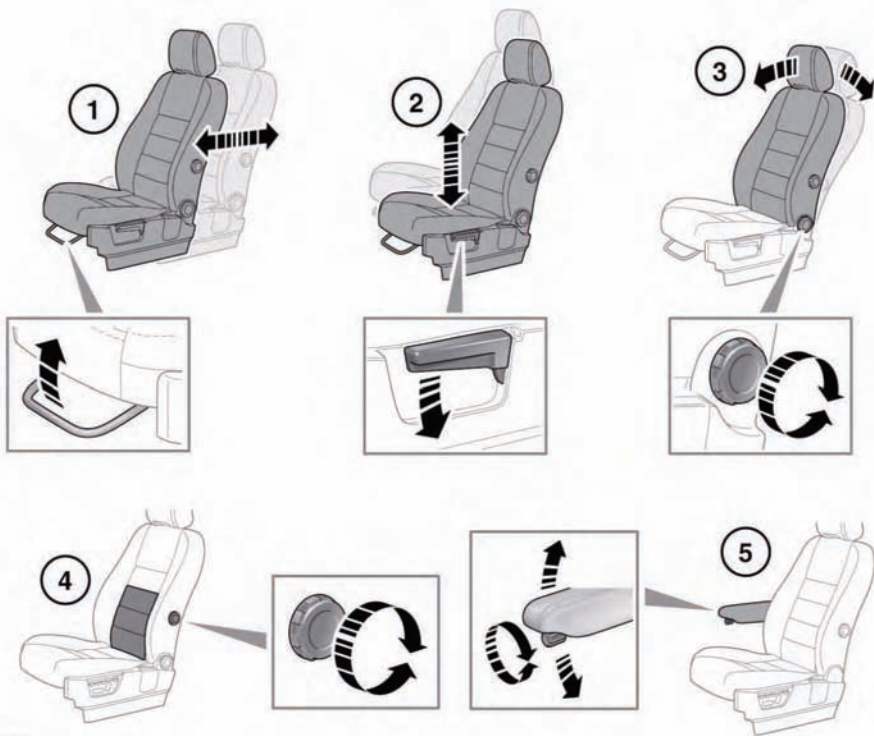

E134909



Do not adjust the seat while the vehicle is moving. Doing so could cause loss of vehicle control and personal injury.

1. Fore and aft adjustment.
2. Height adjustment.
3. Backrest adjustment.
4. Lumbar support adjustment.
5. Armrest height adjustment.

ELECTRIC SEATS

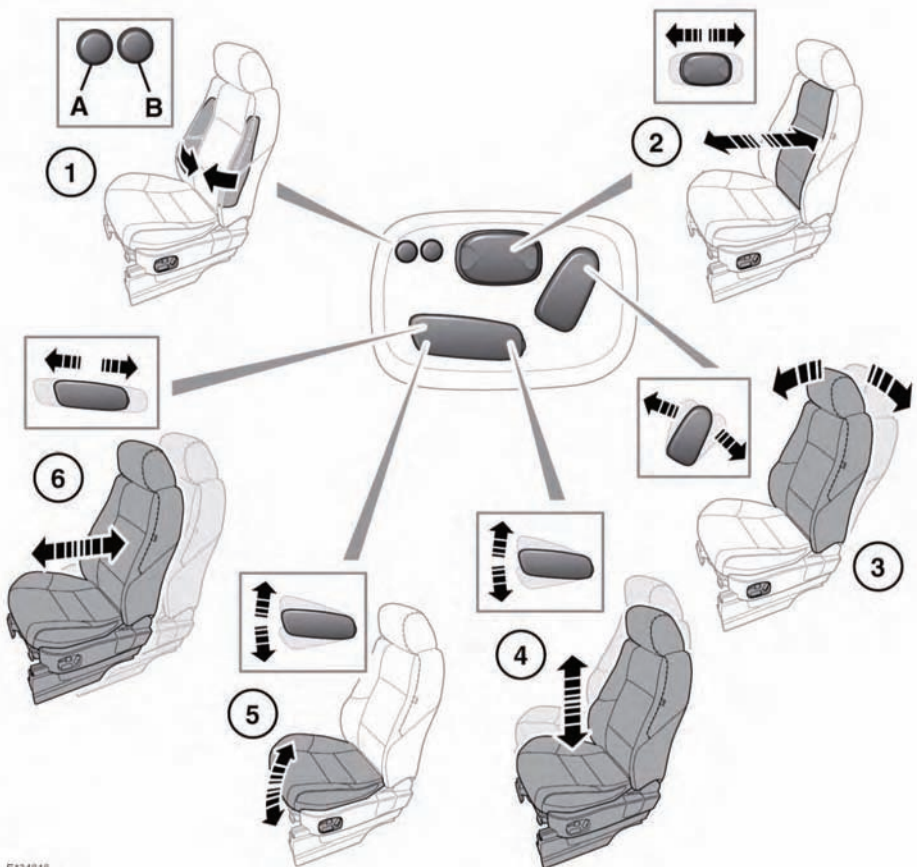

E134818



Do not adjust the seat while the vehicle is moving. Doing so could cause loss of vehicle control and personal injury.

1. Bolster adjustment:
 - A. Bolster inflate.
 - B. Bolster deflate.
2. Lumbar support adjustment.
3. Backrest adjustment.
4. Height adjustment.

5. Cushion tilt adjustment.

6. Fore and aft adjustment.

To adjust the seats, the Smart Key must be in the vehicle and the ignition switched on.

RESTRICTED SEAT TRAVEL

-  If seat movement stops unexpectedly during adjustment, check for and remove any obstructions.

Once any obstructions have been removed, the seat adjustment mechanism can be reset as follows:

Operate the button again, to continue the stalled adjustment, and hold in that position for 2 seconds. When seat movement resumes, hold the button until the end of travel in that direction has been reached. Seat adjustment can now be carried out as normal.

Note: *If no obstructions can be seen, but normal adjustment cannot be carried out without stalling, contact your Dealer/Approved Repairer.*

SITTING IN THE CORRECT POSITION

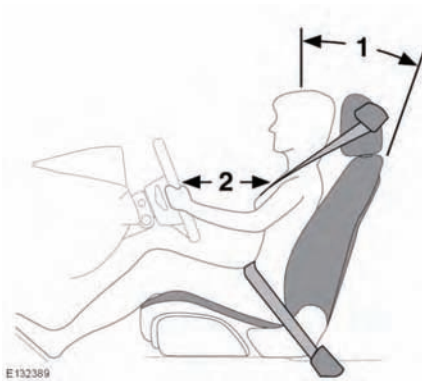

 **The driver and front seat passenger must not ride with the seat fully reclined.**

 **Do not adjust the seat while the vehicle is moving.**

The seat, head restraint, seat belt and airbags, all contribute to the protection of the user. Correct use of these components will give you greater protection. Therefore, you should always observe the following points:

1. Sit in an upright position with the base of your spine as far back as possible and the seatback reclined no more than 30 degrees.
 2. Do not move the driver's seat too close to the steering wheel. Ideally, a minimum distance of 254 mm (10 inches) is recommended between the breastbone and the steering wheel airbag cover. Hold the steering wheel in the correct position, with your arms slightly bent.
- Adjust the head restraint so that the top of the head restraint is above the centre line of the head.
 - Position the seat belt so that it is mid-way between your neck and your shoulder. Fit the strap tightly across your hips, not across your stomach.
 - Ensure that your driving position is comfortable and enables you to maintain full control of the vehicle.

DRIVING POSITION MEMORY

Once you have adjusted the power operated driver's seat, steering column (see **24, ADJUSTING THE STEERING WHEEL**) and exterior mirrors (see **47, EXTERIOR MIRRORS**) for your ideal driving position, the vehicle can memorise these settings for future use.

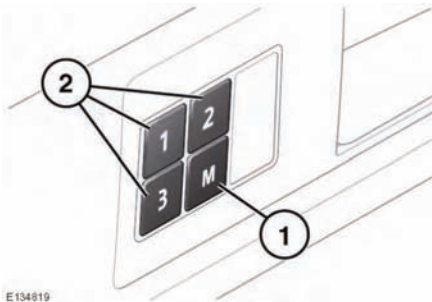

1. Press the memory store (**M**) button to activate the memory function.
2. Press one of the preset buttons within 5 seconds to memorise the current settings. **MEMORY (1, 2 or 3) SETTINGS SAVED** will be displayed on the message centre, accompanied by an audible chime to confirm the settings have been memorised.
3. To recall a stored position press the relevant preset button. **MEMORY (1, 2 OR 3) RECALLED** will be displayed in the message centre.

A seat position will only be memorised during the 5 second active period.

Any existing settings will be over-written when programming a memory position.

FOLDING ARMREST



If fitted, the folding armrest may be stowed by moving to the vertical position. Use the adjuster wheel (arrowed) to set the required height.

Rear seats

FOLDING THE REAR SEATS



Always ensure that objects carried within the vehicle are secured properly.



Never allow passengers to travel in the load space under any circumstances. All vehicle occupants should be seated correctly, and wear a seat belt at all times when the vehicle is in motion.

FOLDING THE SEATS (5 seat vehicle)

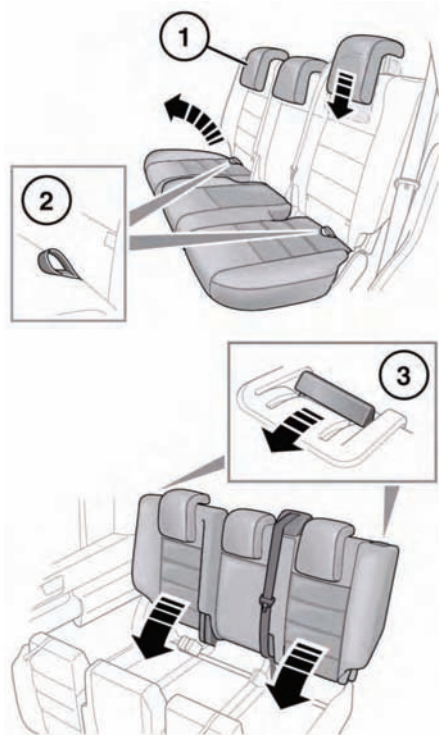

E134913

The split fold rear seat can be folded completely to accommodate large loads, or partially to accommodate large loads and still retain seating for passengers.

To fold part or all of the seat:

1. Fully lower the head restraints.
2. Pull the strap on the required cushion(s), to raise to the vertical position.
3. Pull the seat backrest release lever(s), then lower the backrest(s) until locked into place.

Note: Some 5-seat models are fitted with the same type of seat as the 7-seat model.

ERECTING THE SEATS (5 seat vehicle)



Ensure that when the backrest is raised the locking mechanism is fully engaged. If the backrests are not fully locked in place, red markers will be visible around the backrest levers.

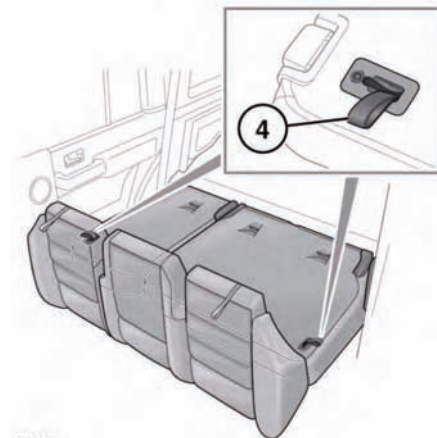

E134914

Pull the strap (4) vertically to unlock the seats, then raise the seats by following the lowering process in reverse.

Note: The head restraints should be raised to the correct position before the seats are used by a passenger.

FOLDING THE SEATS (7 seat vehicle)

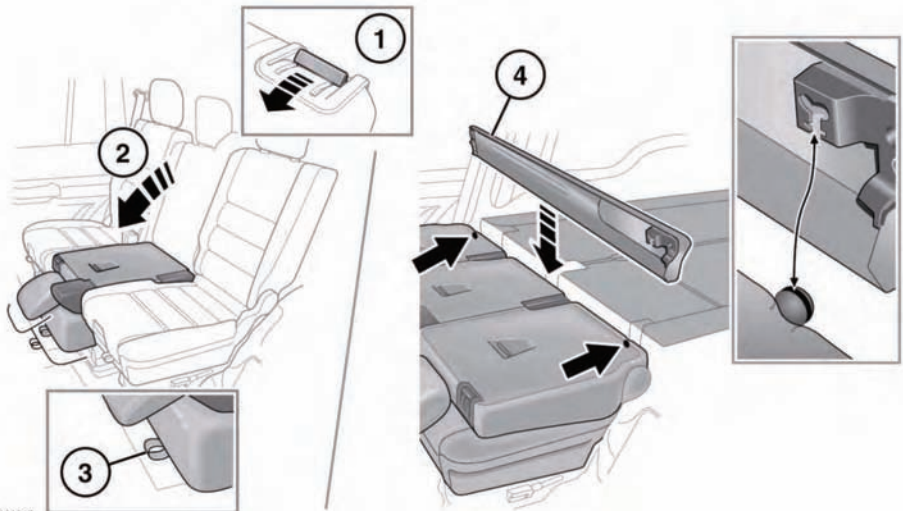

E134917

One of the seats may be folded to form a table for the other two seats, or all three seats may be folded forward to extend the loadspace. A seat may also be folded to gain access to the third row seats.

Note: The rear seats may not be folded if the front seats are in their furthest rearward position.

Note: The centre backrest must always be folded first.

1. Pull the backrest lever forwards.
2. Fold the backrest forwards into the table fold position.
3. Pull the strap at the front of the seat and press down to fold into the loadspace extension position.
4. The loadspace cover may be stowed as shown behind the folded seats.

ERECTING THE SEATS (7 seat vehicle)



The seat position should be checked and physically tested to ensure that the cushions and backrest are secure before driving. If the backrests are not fully locked in place, red markers will be visible around the backrest levers.



Do not attempt to raise the seats when the loadspace cover is stowed behind them. Damage to the loadspace cover will result.

Note: The centre backrest should always be raised last.

1. Pull the strap at the front of the cushion.
2. Grasp the top and bottom of the backrest, lift the seat and return it to the table fold position.
3. Push the release lever forward.

Rear seats

4. Pull the backrest up and push into place. When fully home the latching mechanism will click.

Note: The head restraints should be raised to the correct position before the seats are used by a passenger.

ACCESS POSITION (7 seat vehicle)



The vehicle must not be driven with the rear seats in the access position. Motion of the vehicle could cause the backrest to fall forwards suddenly, causing injury.

To access the third row of seats by this method, the headrest on the second row seat must first be fully lowered.

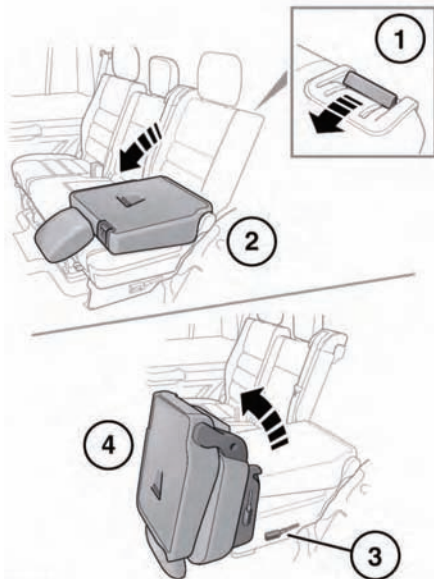

E134918

1. Pull the backrest lever forwards.
2. Lower the backrest into the table fold position.
3. Pull the access lever on the side of the seat.

4. Tilt the seat forwards.

To return the seat to the upright position, lower the seat until the access lever re-engages, then pull the backrest lever and return the backrest to the upright position.

Note: A second row seat cannot be moved directly from the loadspace position to the access position. The backrest must first be returned to the table fold position.



When returning the seat from the access position, ensure nothing is trapped beneath the returning seat.



The seat position should be checked and physically tested to ensure that the cushions and backrest are secure before driving. If the backrests are not fully locked in place, red markers will be visible around the backrest levers.

THIRD ROW SEATS (7 seat vehicle)



Ensure nothing has been left under the third row seat, or in the footwell when folding down the seat, as this could cause damage to the item or the seat.



Beware of trapping fingers when raising and lowering the third row seat.



Do not attempt to raise the third row seats when the loadspace cover is stowed behind the second row seats. Damage to the loadspace cover or the seats may result.

It is possible to fold the third row seats flat.

FOLDING AND ERECTING THE THIRD ROW SEATS

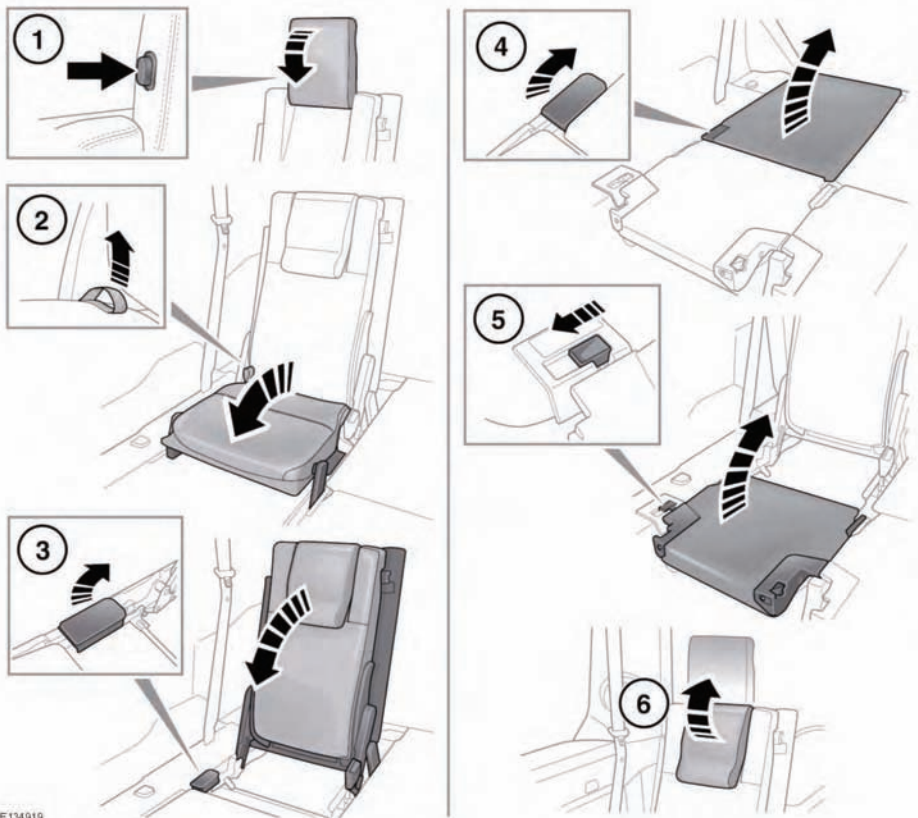

E134919





1. **To fold:** Press the head restraint release button, and fold the head restraint fully downwards.
2. Pull up the release strap (located at rear of cushion) to release the seat. This may require moderate force. Fold the cushion fully forwards until it latches into position.
3. Pull up the backrest lever and fold the backrest fully forwards, until it latches into position in the loadspace floor.
4. **To erect:** Pull backrest lever to release the backrest, and raise to the upright position. Ensure it is fully latched into position.
5. Release the catch to raise cushion. Push into place, ensuring the cushion is latched to the backrest.
6. Raise the head restraint until it latches into position.



The head restraint must always be raised when using the third row seats.

Head restraints

FRONT HEAD RESTRAINTS

-  Adjust the head restraint so that the top of the head restraint is above the centre line of the head. An incorrectly adjusted head restraint increases the risk of death or serious injury in the event of a collision.
-  It is possible to swivel the head restraint forwards or backwards. For greater protection in the event of a collision, the head restraint should be adjusted so that it is as close to the back of the head as is practical.
-  Do not drive, or carry passengers with the head restraints removed from occupied seats. The absence of a correctly adjusted head restraint increases the risk of neck injury in the event of a collision.
-  Never adjust the head restraints while the vehicle is in motion.
-  Always store a removed head restraint securely.

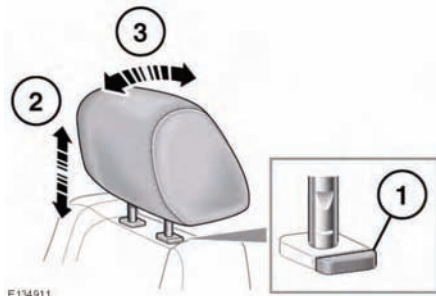

1. Press the locking collar to release the head restraint.
2. Whilst pressing the locking collar, move the head restraint up or down to the required position.

3. Manually tilt the head restraint so that it is as close to the back of the head as is practical.

Manual head restraints may be removed, if required (e.g. to fit larger child seats). Raise the head restraint to its uppermost position and press the locking collar. Lift the restraint out of the seatback.

Ensure the head restraint is refitted before the seat is used by a passenger.

To refit the head restraint, ensure it is facing the correct direction, insert the stems of the head restraint into the sockets and push it downwards until at least the first click.

Note: See 28, **CHILD SEATS**, for details on correct child restraint fitment.

REAR HEAD RESTRAINTS



Adjust the head restraint so that the top of the head restraint is above the centre line of the head. An incorrectly adjusted head restraint increases the risk of death or serious injury in the event of a collision.



Do not drive or carry passengers with the head restraint removed from an occupied seat. The absence of a correctly adjusted head restraint increases the risk of neck injury in the event of a collision.



Always store a removed restraint securely.

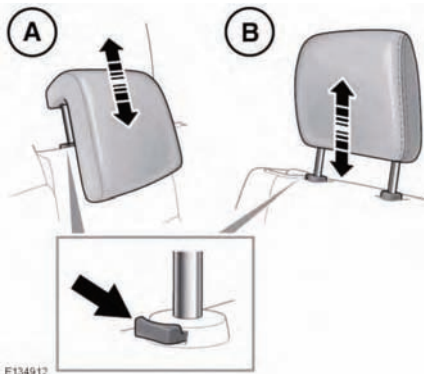

A. 5-seat vehicles.

B. 7-seat vehicles.

To adjust:

- Press the locking button on the collar.
- Raise or lower the head restraint until the top of the restraint is level with the top of the passenger's head.

To remove:

- Press the locking button on the collar.
- Lift the head restraint out of the seat.

To refit:

- Ensure the head restraint is facing the correct direction.
- Insert the stems of the restraint into the sockets on the seatback.
- Push the restraint downwards until at least the first click.

Steering wheel

ADJUSTING THE STEERING WHEEL

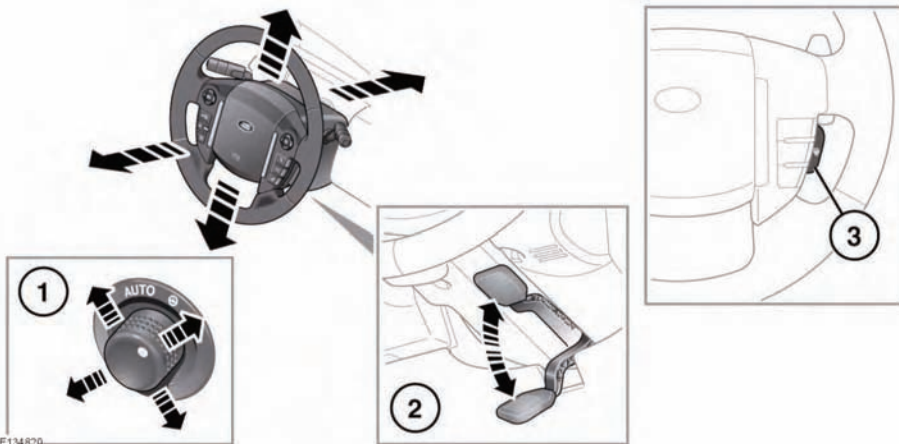

Never adjust the steering column while the vehicle is in motion.

- 1. Electric adjustment:** Move the control up or down to adjust the tilt/height. Move the control forwards or rearwards to adjust reach.
- 2. Manual adjustment:** Move the locking lever (located under the column) downwards to unlock. Move the steering column up, down, in or out, to the desired position. Move the lever fully up to re-lock the column.
- 3. Heated steering wheel:** Press to turn on and off. The switch indicator will illuminate amber when heating is on. When heating is off, the indicator illuminates green (with headlamps on) or does not illuminate (with headlamps off).

ENTRY AND EXIT MODE

With the steering column control (1) in the **AUTO** position, the steering column and driver's seat will move to provide easier entry and exit from the vehicle.

To prevent automatic movement of the driver's seat and steering column, turn the control clockwise to the manual position.

Note: *If the steering column switch is moved away from **AUTO** when the driver's seat and steering column is in the exit position, the driver's seat and steering column will move back to their previous positions when the driver's door is closed and the ignition is switched on.*

Three different steering column and driver's seat positions can be saved and recalled. See **17, DRIVING POSITION MEMORY.**

USING SEAT BELTS AND CHILD SAFETY LOCKS

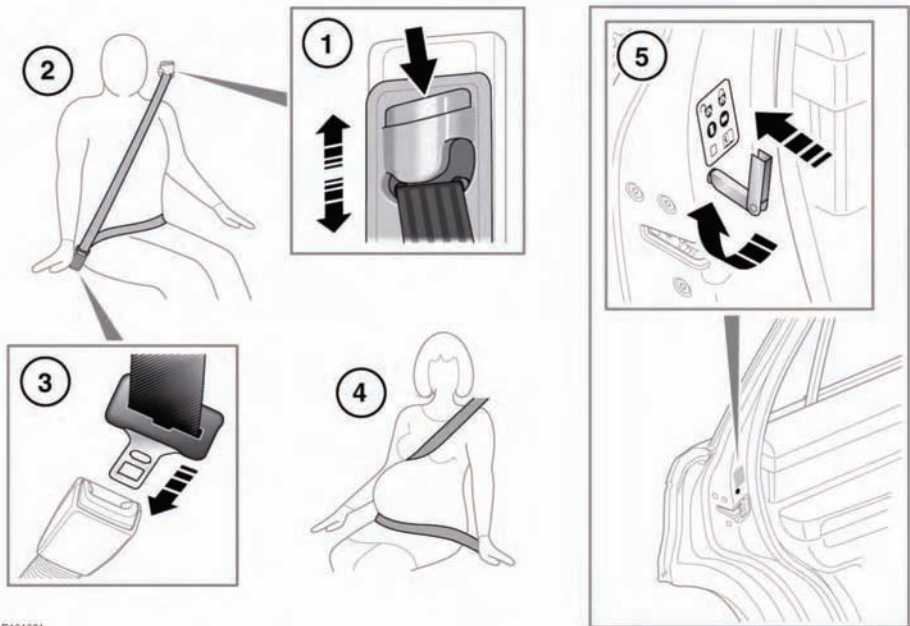

E134821

- 1. Seat belt height adjustment:** Press to release the catch.

With the catch depressed move the mechanism slide up or down to the required height. Ensure that the locking mechanism has engaged.

When correctly positioned the seat belt should cross the collar bone at the mid-point between the neck and end of your shoulder.

Where possible, rear seat passengers should adjust their seating position to achieve the same seat belt position.



Ensure that the height is correctly adjusted and the mechanism is locked in place before driving.



The use of comfort clips or devices that would create slack in the seat belt system, is not advised.



No modifications or additions should be made by the user which will either prevent the seat belt adjusting devices from operating to remove slack, or prevent the seat belt assembly from being adjusted to remove slack.

- 2. Putting on a seat belt:** Draw the belt out smoothly, ensure that the belt height, the seat and your position on the seat, are correct.



Seat belts are designed to bear upon the bony structure of the body, and should be worn low across the front of the pelvis or the pelvis, chest and shoulders, as

applicable; wearing the lap section of the belt across the abdominal area must be avoided.



Seat belts should be adjusted as firmly as possible, consistent with comfort, to provide the protection for which they have been designed. A slack belt will greatly reduce the protection afforded to the wearer.



Belts should not be worn with the straps twisted.



Each belt assembly must only be used by one occupant; it is dangerous to put a belt around a child being carried on the occupant's lap.



The occupants of the front seats should not travel with the seat back at more than 30 degrees from the upright. Doing so will reduce the protection afforded by the seat belt.



Never place anything between you and the seat belt. It can be dangerous and reduce the effectiveness of the seat belt in preventing injury.

3. **Fastening a seat belt:** With the seat belt correctly positioned, place the metal tongue into the buckle nearest to you. Press it in until a click is heard.

To release the seat belt, press the red button.

Note: When releasing the seat belt it is advisable to hold the belt before pressing the release button. This will prevent the belt from retracting too quickly.

4. **Seat belt use during pregnancy:** Position the lap strap comfortably across the hips beneath the abdomen. Place the diagonal part of the seat belt between the breasts and to the side of the abdomen.



Position the seat belt correctly for the safety of the mother and unborn child. Never wear just the lap strap, and never sit on the lap strap whilst using just the shoulder strap. Both of these actions are extremely dangerous, and may increase your risk of serious injury in the event of an accident or during emergency braking.



Never place anything between you and the seat belt in an attempt to cushion the impact in the event of an accident. It can be dangerous, and will reduce the effectiveness of the seat belt in preventing injury.



Ensure that the seat belt is not slack or twisted.

5. **Child safety locks:** If children are to be carried in the rear seat positions, it is recommended that the rear door interior handles are disabled.

To change the child lock settings:-

- Open the door to access the child safety lock.
- Insert the emergency key into the slot, and rotate a quarter of a turn to enable or disable the interior door handle as required.

Note: There are two designs of Smart Key/emergency key, see 5, **UNLOCKING THE VEHICLE**.

SEAT BELT SAFETY



Care should be taken to avoid contamination of the webbing with polishes, oils and chemicals, and particularly battery acid. Cleaning may safely be carried out using mild soap and water.



The belt should be replaced if webbing becomes frayed, contaminated or damaged.



It is essential to replace the entire assembly after it has been worn in a severe impact even if damage to the assembly is not obvious.



If any damage, wear, cuts, defects, or impaired operation are noted with the seat belts, the vehicle should be taken to a Land Rover Dealer/Authorised Repairer for immediate attention. Do not use the vehicle if the seat belts cannot be operated correctly.



Do not carry hard, fragile, or sharp items between your person and the seat belt.



Seat belts should be worn by all vehicle occupants, for every journey no matter how short.



Never wear just the lap belt or just the shoulder belt of a lap/shoulder diagonal seat belt. Both of these actions are extremely dangerous and may increase your risk of injury.



When using seat belts to restrain items other than occupants, take care to ensure that the belts are not damaged, or exposed to sharp edges.

SEAT BELT CHECKS

Note: If the vehicle is parked on an incline, the seat belt mechanism may lock. This is not a fault and the belt should be gently eased out from the upper anchorage.

The seat belts should be inspected regularly to check for fraying, cuts, wear to the webbing and the condition and security of the mechanism, buckles, adjusters and mounting points.

- With the seat belt fastened, give the webbing near the buckle a quick upward pull. The buckle must remain securely locked.
- With the seat belt unfastened, unreel the seat belt to the limit of its travel. Check that it unreels smoothly with no snatches or snags. Allow the belt to fully retract, again checking for smooth operation.
- Partially unreel the seat belt, then hold the tongue plate and give a quick forward pull. The mechanism must lock and prevent any further unreeling.

If any of the seat belts fail to meet those criteria, immediately contact your Dealer/Authorised Repairer.

SEAT BELT WARNING LAMP





If the driver's seat belt is not fastened when the vehicle is in motion, a chime will be heard and the seat belt warning lamp will illuminate. The warning chime and warning lamp will also be activated if the front passenger seat is occupied without the seat belt being fastened.

Occupant safety

Note: Objects on the front passenger seat may activate the seat belt reminder. It is recommended that any objects placed on the front passenger seat are secured using the seat belt.

CHILD SEATS

 For optimum safety, children should travel in the rear of the vehicle at all times; front passenger seat travel is not recommended. However, if it is essential that a child travels in the front (not permitted in Australia), set the vehicle seat fully rearward and seat the child in an approved forward-facing child seat. Do not use a rear-facing child seat - an inflating airbag could impact with the seat and cause serious injury.

 Do not use a forward facing child seat until the child using it is above the minimum weight of 9 kg (20 lb.) and able to sit up unaided. Up to the age of two, a child's spine and neck are not sufficiently developed to avoid injury in a frontal impact.

 Do not allow a baby or infant to be held or carried on the lap. The force of a crash can increase effective body weight by as much as thirty times, making it impossible to hold onto the child.

 Children typically require the use of a booster seat appropriate to their age and size, thereby enabling the seat belts to be properly fitted, reducing the risk of injury in a crash. Children could be endangered in a crash if their child restraints are not properly secured in the vehicle.



Do not use a child seat that hooks over the seat back. This type of seat cannot be satisfactorily secured and is unlikely to be safe for your child.



Extreme hazard! Do not use a rearward facing child restraint on a seat protected by an airbag in front of it!

The seat belts fitted to your vehicle are designed for adults and larger children. For their safety it is very important for all infants and children under 12 years of age to be restrained in a suitable child safety seat appropriate to their age and size.



E132397

This symbol, affixed to the end of the fascia on the passenger side, warns against the use of a rear-facing child seat in the front passenger seat, when a front passenger airbag is fitted and operational.

If it is essential that a child travels in the front passenger seat (and national legislation permits this), Land Rover recommends that the following preparations are made before fitting the child restraint.

- Disable the front passenger airbag.
- Adjust the front passenger seat fully rearwards.
- Adjust the lumbar support to its minimum support position.
- Adjust the seat cushion to its highest position. If cushion rake adjustment is possible, adjust it to its lowest position.

- Adjust the seat back to the fully upright position.
- Adjust the seat belt adjustable upper anchorage to its lowest position.

CHILD RESTRAINT CHECK LIST

Every time a child travels in the vehicle observe the following:-

- Use appropriate child restraints.
- Carefully follow the restraint system manufacturers instructions.
- Adjust the harnesses for every child on every trip.
- Ensure that all slack is removed from the adult seat belt.
- Always attach the top tether when installing an ISOFIX seat.

- Always check the security of the child restraint.
- Do not dress a child in bulky clothing, or place any objects/padding between the child and the restraint.
- Regularly check the fit and condition of child restraints. If the fit is poor, or wear/damage is visible replace the restraint immediately.
- Set a good example - always wear your seat belt.



Child restraint anchorages are designed to withstand only those loads imposed by correctly fitted child restraints. Under no circumstances are they to be used for adult seat belts, harnesses or for attaching other items or equipment to the vehicle.

CHILD SEAT POSITIONING



Information given within the table is correct at the time of going to press. However, availability of child restraints may change. Please consult your Dealer/Authorised Repairer for the latest recommendation.

Note: *The information contained in the following table may not be applicable to all countries. If you are in any doubt regarding the type and fitment of child seats seek advice from your Dealer/Authorised Repairer.*



Crash statistics show that children are safest when properly restrained in a child or infant restraint system that is secured in a rear seating position.

Note: *Ages given are approximate. In case of doubt, the child's weight not age should be used when considering an appropriate child seat.*

Occupant safety

Note: The legislation which governs how and where children should be carried when travelling in a vehicle, is subject to change. It is the responsibility of the driver to comply with all regulations in force.

| Mass group. | 0 = Up to 10 kg (22 lb) 0-9 months | 0+ = Up to 13 kg (29 lb) 0-18 months | I = 9-18 kg (20-40 lb) 9 months to 4 years | II = 15-25 kg (33-55 lb) 4-9 years | III = 25-36 kg (55-80 lb) 8-12 years |
|--------------------------------------|--|--|---|--|--|
| Seating positions | | | | | |
| Front passenger* | U | U | U | U | U |
| Rear seats (5 seat vehicle) | L | L | L | L | L |
| Second row seats (7 seat vehicle) | U | U | U | U | U |
| Third row seats | X | X | UF | UF | UF |

- U = Suitable for universal category restraints approved for this mass group.
- UF = Suitable for Forward-facing universal category restraints approved for this mass group.
- X = not suitable for children in this mass group.
- L = suitable for particular child restraints as listed in the Child seat usage table (see below).

* Always ensure that the passenger airbag has been disabled before using a child restraint in this seating position. The seat back needs to be adjusted to the fully upright position. If the head restraint has been removed, ensure it is refitted before the seat is used by a passenger.

RECOMMENDED CHILD SEATS

| Child size/age | Recommended seat |
|------------------|-----------------------------|
| Groups 0 and 0+ | Britax/Römer Baby Safe Plus |
| Group I | Britax/Römer Duo Plus |
| Group II and III | Britax/Römer Kid Plus |

ISOFIX ANCHOR POINTS (not Australia)

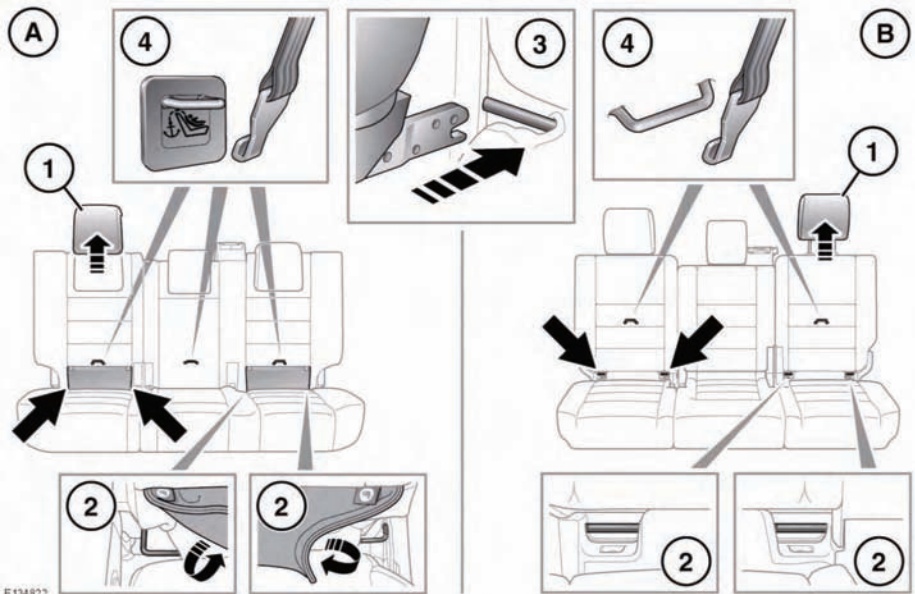

A. 5-Seat vehicles.

B. 7-Seat vehicles.

Both of the outer seat positions on the rear seat are equipped to accept ISOFIX restraints.



This symbol is shown on a label sewn into the seats to indicate the position of the ISOFIX lower anchorages.

To install an ISOFIX child seat:

1. Raise or remove the head restraint.
2. Lift the velcro flap to expose the ISOFIX locking mechanism.
3. Slide the child seat into the locking mechanism.

4. Upper tether anchorage points are provided at the back of the seats if required, see **33, INSTALLING TETHER ANCHORAGE CHILD RESTRAINTS**.

Note: Always ensure that if an upper tether is provided, it is fitted and tightened correctly.

Note: ISOFIX child restraints are only fitted to the second row of seats.

Test the security of the child restraint. To do this, attempt to pull the restraint away from the vehicle seat and twist the restraint from side to side. Even if the restraint appears secure, you should still check the anchor points visually, to ensure correct attachment.



Do not attempt to fit ISOFIX restraints to the centre rear seating position. The anchor bars are not designed to hold an ISOFIX restraint in this position.

Occupant safety



If the restraint is not correctly anchored, there is a significant risk of injury to the child in the event of a collision or emergency braking.

Note: Always refit a removed head restraint after the child restraint is removed. See **23, REAR HEAD RESTRAINTS.**

| Mass group as shown on child restraint | Size classes | Fixtures | Vehicle ISOFIX positions |
|--|---------------|----------------------------|--------------------------|
| Carrycot | F/G | ISO L1/L2 | X |
| 0 = Up to 10 kg (22 lb) 0-9 months | E | ISO R1 | IL* |
| 0+ = Up to 13 kg (29 lb) 0-18 months | C/D/E | ISO R1/R2/R3 | IL* |
| I = 9 to 18 kg (20 to 40 lb) 9 months - 4 years | C/D A/B1/B | ISO R2/R3 ISO F2/F2X/F3 | X IUF |
| II = 15 to 25 kg (33 to 55 lb) 4-9 years | N/A | N/A | N/A |
| III = 22 to 36 kg (49 to 80 lb) 8-12 years | N/A | N/A | N/A |

- IUF = Suitable for ISOFIX forward child restraint systems of universal category approved for use in the mass group.
- IL = These ISOFIX child restraint systems are of the specific vehicle, restricted or semi-universal categories.
- X = Not suitable for ISOFIX child restraint fitment in this mass group.
- * = Child seat suitable for use in these locations, is the Britax/Römer Baby Safe Plus ISOFIX.

Note: Ages given are approximate. In case of doubt, the child's weight not age should be used when considering an appropriate child seat.

Note: The information contained in the table may not be applicable to all countries. If you are in any doubt regarding the type and fitment of child seats seek advice from your Dealer/Authorised Repairer.

Note: ISOFIX anchorages are provided for second row outer seating positions. ISOFIX child restraints should be securely attached following the manufacturers instructions at these locations only.

TETHER ANCHORAGE POINTS (Australia only)

Your vehicle is equipped with anchorage points on the back of the second row seat frames. These should be used to attach straps from child seats or restraint systems.

Note: A tether anchorage is provided for the centre seat position. Do not use this anchor position with an ISOFIX child seat.

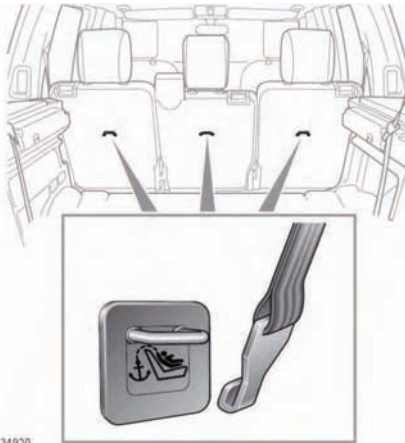

E134920



Child restraint anchorages are designed to withstand only those loads imposed by correctly fitted child restraints. Under no circumstances are they to be used for adult seat belts, harnesses or for attaching other items or equipment to the vehicle.



Always follow the child seat or restraint system manufacturer's instructions when fitting tether straps.



When fitting a child seat or restraint system, always pass the tether strap over the top of the seat back and beneath the head restraint.



If a child seat or restraint system is to be fitted to the centre seating position, the centre armrest must be in the stowed position (folded into the seat).

INSTALLING TETHER ANCHORAGE CHILD RESTRAINTS

1. Install the child restraint securely in one of the rear seating positions.
2. Pass the tether strap over the seat back and beneath the head restraint.
3. Attach the tether strap hook to the tether anchor point on the back of the seat. Ensure that the tether strap hook is facing the correct way (see illustration).
4. Tighten the tether strap according to the manufacturer's instructions.

BOOSTER SEATS

In a situation where a child is too large to fit into a child safety seat but is still too small to safely use just the three point belt, a booster seat is recommended for maximum safety. Follow the manufacturer's instructions for fitting and use, then adjust the seat belt to suit.

AIRBAGS

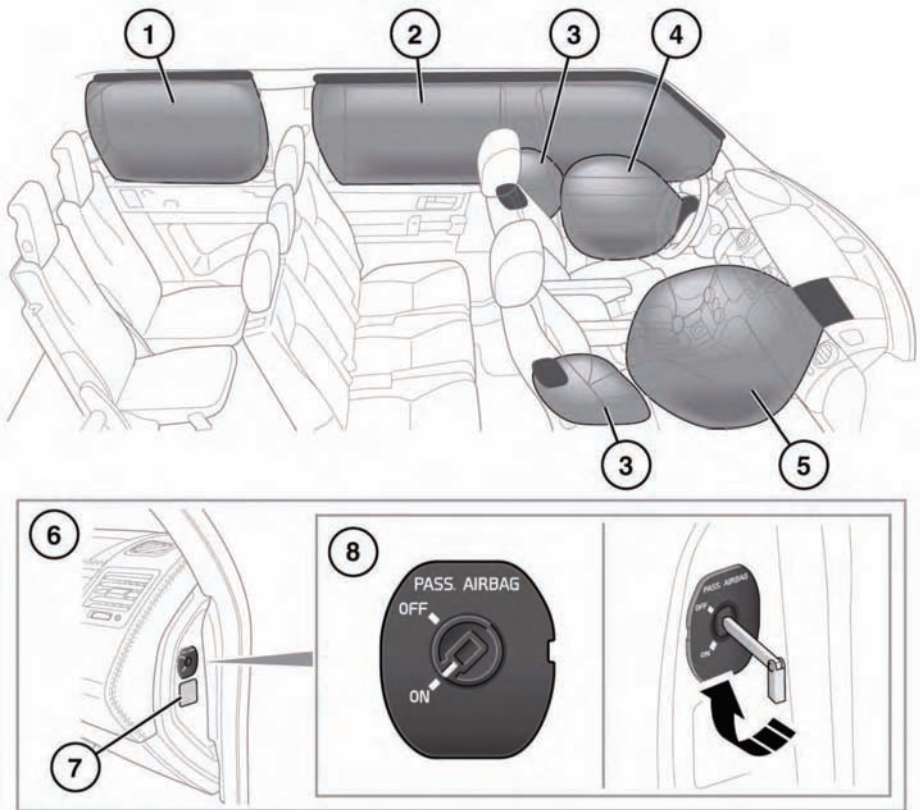

E134921





1. 3rd row seats, curtain airbag
2. Main curtain airbag.
3. Side airbags.
4. Driver's front and side airbags.
5. Passenger front and side airbags.
6. Passenger airbag disable switch location
7. Passenger airbag warning label
8. Passenger airbag disable switch operation.

Note: The general location of airbags fitted to the vehicle are marked by the word AIRBAG.

Always contact your Dealer/Authorised Repairer if:

- An airbag inflates.
- The front or sides of the vehicle are damaged.
- Any part of the Airbag Supplementary Restraint System (SRS) shows signs of cracking or damage, including trim covering airbags.

The passenger front airbag can be disabled using the passenger airbag disable switch.

-  The passenger airbag should be disabled only when a rearward facing child restraint is fitted to the front passenger seat.
-  Crash test data and statistics show that the safest place for a child to be restrained is in a child seat correctly fitted to the vehicle's rear seat.
-  Do not use a child restraint on a seat protected by an operational airbag in front of it. Doing so presents a high risk of death or serious injury to the child in the event of an accident.
-  Do not fit a child restraint to the front passenger seat if the SRS warning light illuminates continuously with the ignition on.



To disable the passenger front airbag:

1. Remove the emergency key from within the Smart Key. See 5, **UNLOCKING THE VEHICLE**.
2. Insert the emergency key blade into the slot in the switch and rotate to the OFF position.
3. Make sure the passenger airbag operational status indicator illuminates yellow.





Note: The indicator will only illuminate when the ignition is turned on.



E135480

-  As soon as the child seat is removed from the front passenger seat, the airbag must be turned on. Failure to do so, will put any front seat passengers at greater risk of death or serious injury in the event of an accident.
-  When checking the operational status of the front passenger airbag, ensure that the ignition is switched on.

AIRBAG OPERATION

-  For the airbags to operate correctly the roof lining and door post trims must be in good condition, correctly fitted, and free from obstruction. Any damage, wear, or incorrect fitment should be referred to your Dealer/Authorised Repairer as soon as possible for examination and repair.
-  Do not allow passengers to obstruct the operation of the airbags by placing any part of their person, or any objects, in contact with, or close to, an airbag module. Only use approved accessories (e.g. seat covers).
-  Ensure that a gap is maintained between the side of the vehicle, and the head and torso. This will enable unobstructed inflation of the curtain, and seat mounted side airbags.
-  Airbags inflate at high speeds. To minimise the risk of injury, ensure that all vehicle occupants wear correctly positioned seat belts, sit correctly in the seats, and position the seats as far back as practical.

Occupant safety



Airbag inflation takes place instantaneously, and cannot protect against the effects of secondary impacts. Under these circumstances the only protection will be provided by a correctly worn seat belt.



Phone systems should only be installed by qualified persons familiar with the operation of, and requirements for, vehicles fitted with SRS. If you are in any doubt, seek advice from your Dealer/Authorised Repairer.

Airbag deployment is dependent on the rate at which the passenger compartment changes velocity following the collision. Circumstances affecting different collisions (vehicle speed, angle of impact, type and size of object hit, etc.), vary considerably and will affect the rate of deceleration accordingly.

Airbags cannot deploy correctly if they are obstructed. Examples of obstructions are:-

- Any part of an occupants body in contact with, or close to, an airbag cover.
- Objects placed on, or close to, an airbag cover.
- Clothing, sun screens, or other material hanging from grab handles.
- Clothing, cushions, or other material, covering seat mounted airbags.
- Seat covers which are not approved by Land Rover, or specifically designed for use with seat mounted airbags.

This list is not exhaustive, and it remains the responsibility of the driver and passengers to ensure that the airbags are not obstructed in any way.

Note: *The airbags and SRS are not designed to operate as a result of:*

- Rear impacts.
- Minor front impacts.

- Minor side impacts.
- Heavy braking.
- Driving over bumps and pot holes.



High speed impacts may cause serious injury or death irrespective of safety features fitted to a vehicle.



The airbag SRS cannot provide protection in some types of impact. Under these circumstances the only protection will be provided by a correctly worn seat belt.

FRONT AIRBAGS

The front passenger and driver air bags are able to deploy in two stages, depending on the severity of the frontal impact. In a severe impact, the air bags inflate fully to offer maximum protection. In a lesser impact, full deployment is not required, so the air bags are partially inflated.

SIDE AND CURTAIN AIRBAGS

The seat mounted side air bags are designed to protect the thorax region of the torso and will deploy only in the event of a side impact and then, only on the side of the impact.

The curtain air bags are deployed in side impact and rollover events, providing greater protection from serious head injuries. They deflate at a slower rate than the front or side air bags.

SEAT BELT PRE-TENSIONERS

The seat belt pre-tensioners activate in conjunction with the Supplementary Restraint System (SRS) to provide additional protection in the event of a severe frontal impact. They automatically reduce any slack in a seatbelt to reduce forward movement of a front seat occupant.



The seat belt pre-tensioners will activate only once and then must be replaced. Failure to replace them will reduce the effectiveness of the SRS in reducing the risk of serious injury or death in the event of an accident.



After any impact, have the seat belts and pre-tensioners checked and, if necessary, replaced by a Dealer/Authorised Repairer.

AIRBAG DEPLOYMENT EFFECTS



When an airbag inflates, a fine powder is released. This is normal and not an indication of a malfunction. The powder may cause irritation to the skin and should be thoroughly flushed from eyes and any cuts or abrasions.



Airbag deployment is accompanied by a very loud noise which may cause discomfort and temporary loss of hearing.

AIRBAG WARNING LAMP



The airbag warning lamp is mounted in the instrument pack, and will illuminate as a bulb check when the ignition is turned on.



If the warning lamp indicates that a fault is present in the system, do not use a child restraint on the front passenger seat.

If any of the following warning lamp conditions occur, the vehicle should be checked by your Dealer/Authorised Repairer immediately.

- The warning lamp fails to illuminate when the ignition is turned on.
- The warning lamp fails to extinguish within 6 seconds of the ignition being turned on.

- The warning lamp illuminates at any time other than the bulb check, when the ignition is turned on.

AIRBAG SERVICE INFORMATION



Do not attempt to service, repair, replace, modify, or tamper with, any part of the SRS. This includes wiring or components in the vicinity of SRS components. Doing so may cause the system to trigger, or render the system inoperative.



Do not use any electrical test equipment or devices in the vicinity of SRS components or wiring. Doing so may cause the system to trigger, or render the system inoperative.

All of the following operations should only be carried out by a Dealer/Authorised Repairer, or suitably qualified person:-

- Removal or repair of any wiring or component in the vicinity of any SRS components.
- Installation of electrical, or electronic, equipment and accessories.
- Modification to the front or sides of the vehicle exterior.
- Attachment of accessories to the front or sides of the vehicle.

LIGHTING CONTROL

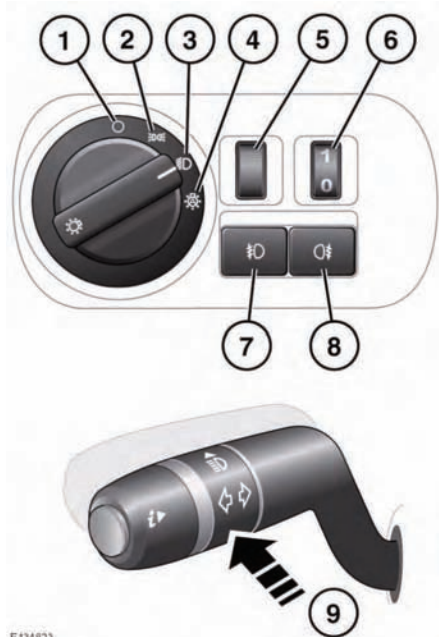

1. Headlamps/side lamps off.
2. Side lamps on.
3. Low beam headlamps on.
4. Autolamps on: With the switch in this position and the ignition on, the side lamps, low beam headlamps and licence plate lamps illuminate automatically when the ambient light level is low. Auto high beam and Headlamp courtesy delay may also be activated (see below).
5. Dimmer control.
6. Halogen lamps height adjuster.
7. Rear fog lamps on/off: When the rear fog lamps are on, the rear fog lamp warning lamp will illuminate.

8. Front fog lamps on/off: When the front fog lamps are on, the front fog lamp warning lamp will illuminate.
9. High beam on/off/flash: When low beam headlamps are switched on, push the indicator stalk to change to high beam (the high beam warning lamp will illuminate). To flash the headlamps at anytime, briefly pull the indicator stalk and release it.

Note: Do not use high beam where it may dazzle other road users.

DAYLIGHT RUNNING LAMPS

With the main lighting control in the Off position (1), low beam headlamps, side lamps, tail, license plate lamps and, where fitted, side marker lamps, will switch on automatically under the following conditions:

- The ignition is on.
- The gear selector is out of park (automatic transmission).
- The parking brake is not applied (is released) - market dependent.



Unless required or prohibited by law, daylight running lamps can be disabled or enabled by your Dealer/Authorised Repairer.

HEADLAMP COURTESY DELAY

This feature operates whenever the lamps master switch is left in the Auto position (4), and the ignition is turned off. The headlamps will remain illuminated for up to 240 seconds.

Note: The time delay may be changed via the **Vehicle set-up menu**, see **52, INTERACTIVE CONTROLS**.

AUTO HIGH BEAM

This feature automatically selects and deselects high beam, under specific conditions of road lighting and in the absence of other vehicle's lights. The system is only active when the ambient light drops below a predetermined level.

Note: It is not recommended that auto high beam is used while driving off road.

For auto high beam to become operational, the main lighting switch must be in the Auto position (4), with low beam headlamps selected.

The system will only activate when the vehicle speed exceeds 40 km/h (25 mph). The system will deactivate when vehicle speed drops below 24 km/h (15 mph).

To manually select high beam, move the stalk to the high beam position as normal. To return to Auto high beam, move the stalk back to the central position.

To manually override to low beam from high beam, pull the stalk to the flash position and auto high beam will be cancelled. To return to auto high beam, push the stalk to the high beam position and then return it to the central position.



A green warning lamp in the instrument pack illuminates when auto high beam is selected.

To turn off auto high beam, turn the main lighting control from Auto to headlamps on.

This feature can be disabled/enabled via the **Vehicle set-up** menu, see **52, INTERACTIVE CONTROLS**.

Note: The following may affect the operation of auto high beam:-

- Highly reflective road signs.
- Vehicles with dim headlamps.
- Adverse weather conditions.
- Dirty sensor.
- Dirty, damaged, or misted windscreen.

Note: The system cannot be relied upon to activate or de-activate high beam in all possible circumstances. It remains the driver's responsibility to ensure correct use of the headlamps at all times.

Note: Ensure that the sensor on the back of the rear view mirror is not blocked or obstructed.

ADAPTIVE FRONT LIGHTING SYSTEM (AFS)

When cornering using low beam, AFS will adjust the headlamp beams to provide improved illumination in the direction of travel.

AFS is deactivated when:-

- Reverse gear is selected.
- The vehicle is stationary.
- Daylight running lamps are on.

If a system fault is detected the headlamps will attempt to move to the central position, and remain stationary. The AFS warning lamp will illuminate to indicate that a fault is present. If the warning lamp illuminates, contact your Dealer/Authorised Repairer as soon as possible.

Exterior lights

HEADLAMPS - DRIVING ABROAD

Depending on the vehicle specification, the headlamps are either manually adjustable for travelling in countries which drive on the opposite side of the road, or adjustment free.



E135218

Adjustment free headlamps: If the top of the headlamps are marked with the symbols shown above, they are adjustment free. no mechanical adjustment is required or the need for any external obscuration decals.

Manually adjustable headlamps: If there are no symbols on the headlamp, there is a lever in each headlamp which allows you to manually adjust the beam pattern.

When new, the lever will be set to the correct position for the country in which the vehicle is sold. To change the pattern for driving on the alternate side of the road, move the lever to the alternate position, see **40, ADJUSTING XENON HEADLAMPS** or **41, ADJUSTING HALOGEN HEADLAMPS**.

Note: The headlamps must be removed in order to change the beam pattern, see **182, HEADLAMP REMOVAL**.

Note: On LHD vehicles fitted with halogen headlamps, the lever is on the left hand side of the bulb aperture.

Note: When changing the beam pattern using the lever, ensure that you change the lever position on both headlamps.

Note: If the Auto high beam feature is enabled, you should also configure the system for the side of the road on which you are driving. See **52, INTERACTIVE CONTROLS**.

ADJUSTING XENON HEADLAMPS

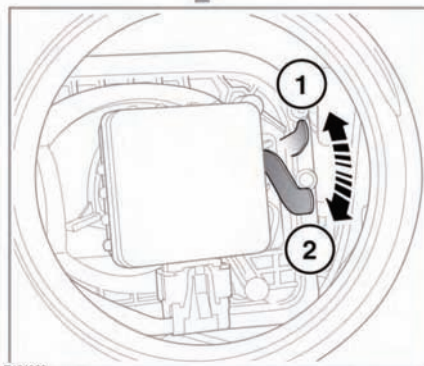
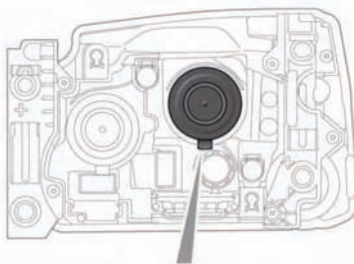

E134922

1. Lever in the correct position for the market where the vehicle was originally sold.
2. Lever in the correct position for when driving in countries where they drive on the opposite side of the road.

With the domed cap removed, move the lever to the appropriate position.

ADJUSTING HALOGEN HEADLAMPS

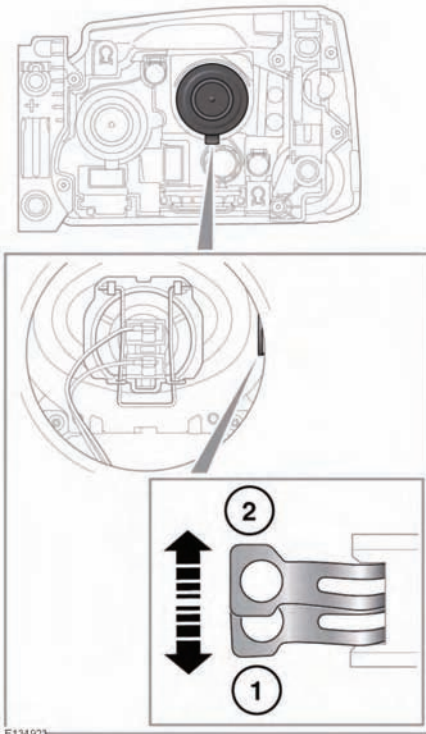

1. Lever in the correct position for the market where the vehicle was originally sold.
2. Lever in the correct position for when driving in countries where they drive on the opposite side of the road.

With the domed cap removed, depress the lever and move to the appropriate position.

HEADLAMP LEVELLING

(Halogen headlamps only)

Use the headlamp levelling control to account for vehicle loading changes.

| Vehicle load | Switch position |
|------------------------------------|-------------------------------------|
| Driver only | 0 |
| Driver and front seat passenger | 0 |
| Driver and passengers in all seats | Rotate down one position from 0. |
| Maximum gross vehicle weight | Rotate down two positions from 0. |
| Maximum rear axle load | Rotate down three positions from 0. |

HEADLAMPS - CONDENSATION

Misting of lamp lenses can occur under some atmospheric conditions. This will not affect the performance of the lamps and will clear during normal operation.

Interior lights

INTERIOR LIGHTS

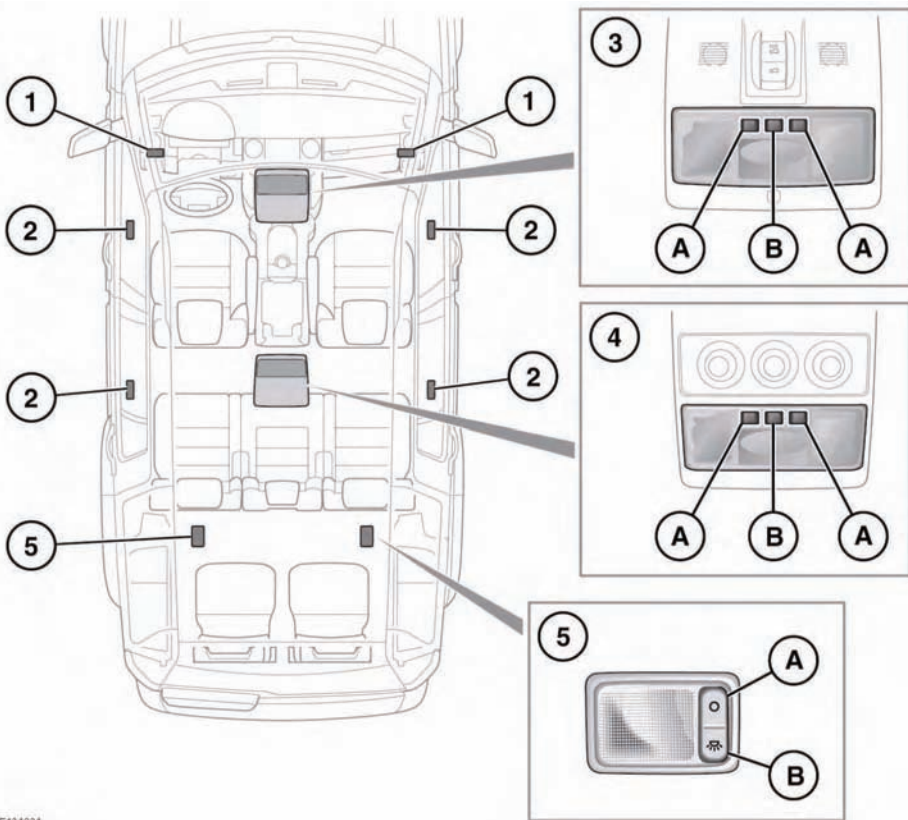

E134834

- 1. Sun visor lamps:** Switch on or off as required using the switch.
- 2. Puddle lamps:** Automatically illuminate when the doors are opened.
- 3. Map reading/interior lamps:**
 - A. Map light controls (on/off).**
 - B. Main interior lamp control (on/off/Auto).**
To activate or deactivate Auto mode, press and hold for longer than 3 seconds. In Auto mode the lamps will illuminate when a door is opened.
- 4. Rear interior light control:**
 - A. Map light controls (on/off).**
 - B. Main interior lamp control (on/off/Auto).**
To activate or deactivate Auto mode, press and hold for longer than 3 seconds. In Auto mode the lamps will illuminate when a door is opened.
- 5. Third row seating/loadspace interior lamps:**
 - A. Press to turn off.**
 - B. Press to turn on.**

WIPER OPERATION

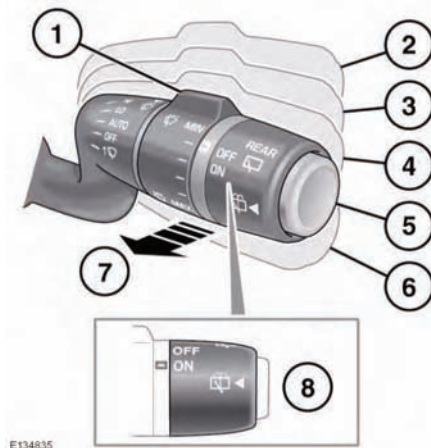

E134835



Feature (1.) can be enabled/disabled by your Dealer/Authorised Repairer.

1. Intermittent wipe delay: Rotate the control to adjust the intermittent period. The intermittent delay period will vary and is controlled by either vehicle speed or a rain sensor. The control must be in position (4) to be operational.
2. High speed wipe.
3. Low speed wipe.
4. AUTO or intermittent wipe: AUTO is controlled by either a rain sensor or vehicle speed. In this position, the rain sensor becomes active and will determine when the wipers are required to operate.
If your rain sensor is not configured by your Dealer/Authorised Repairer, intermittent wipe will operate in conjunction with the setting of control (1).

5. Rear window wash/wipe: Press and hold to operate the rear washer and wiper. The wiper will operate for two further wipes after the button is released. After a few seconds a drip wipe process will clear any residual water.
6. Single wipe of windscreen, or hold down for further continuous wipes.
7. Windscreen wash/wipe: Pull and hold to operate the front washers and wipers. The wipers will operate for three further wipes after the stalk is released. After a few seconds a drip wipe will clear any residual water.
8. Rear wiper: To operate, rotate to **ON**.



Do not operate the windscreen wipers on a dry screen.



In freezing or very hot conditions, ensure that the wipers have not stuck to the glass.



Remove any snow, ice or frost from the screen, around the wiper arms and blades and the screen scuttle, before operating the wipers.

Note: If the wiper blades become stuck or jammed, an electronic cut-out may temporarily halt wiper operation. If this happens, switch off the wipers and the ignition. Clear any obstructions and free the wiper blades, before attempting to switch on the ignition.

SPEED-DEPENDENT MODE

If vehicle speed drops below 8 km/h (5 mph) with the wipers operating, the wipers will switch to the next lowest speed. When vehicle speed increases to over 8 km/h (5 mph), the original wiper speed setting is restored automatically.

In vehicles not fitted with a rain sensor, the frequency of intermittent wipe adjusts according to vehicle speed.

Wipers and washers

The intermittent delay period can be adjusted via the collar (1), but will also reduce automatically as vehicle speed increases.



This feature can be enabled or disabled by your Dealer/Authorised Repairer.

RAIN SENSOR



Ensure that the wipers are switched off before entering a car wash. If the rain sensitive wipers operate during the car washing process, damage may occur to the wiper mechanism.

The rain sensor is able to detect the presence and amount of rain/dirt/snow on the windscreen and automatically activates the windscreen wipers accordingly. Static droplets may not be detected on initial start-up, use a single wipe to clear the screen.

To activate the rain sensitivity wipers, move the wiper stalk to the rain sensor position (4) and adjust the rain sensitivity control (1) as required. When rain sensitive wipers are activated and when sensitivity is increased, a single wipe will operate.

HEADLAMP WASHERS

If the headlamps are on, and there is sufficient liquid in the washer reservoir, operating the screen wash will also power-wash the headlamps.

The headlamp power wash will operate on every fifth operation of the screen washer, provided the headlamps are still switched on and approximately 10 minutes have elapsed since the last headlamp wash.

Switching the headlamps or ignition off and back on again, will reset the cycle.

Note: *The headlamp washers are inhibited when the washer fluid reservoir level is low.*

ELECTRIC WINDOWS

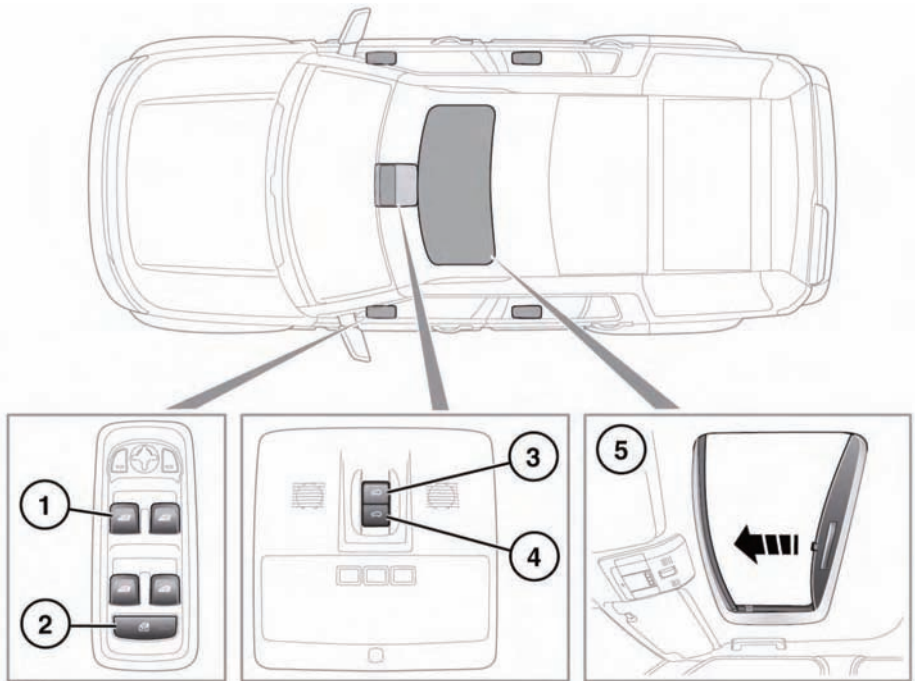

E134836

1. Window switches:

The windows will operate for 5 minutes after the engine is switched off, as long as none of the doors are opened.

2. Rear window isolator button.



If children are carried in the rear seats, the isolator switch should be used to prevent operation of the windows. If the windows are operated by young children there is a risk of serious injury or death.

3. Sunroof close/tilt switch:



Wherever possible remove any snow, ice, dirt, and leaves etc. from the sunroof mechanism before closing. Failure to do so may damage the sunroof mechanism.

- With the roof closed, briefly press to tilt the sunroof open.
- With the roof fully open, briefly press to close the roof.

Press the button again to stop movement.

4. Sunroof open/close switch:
- With the roof closed, briefly press to fully open. Press again to stop movement.
 - With the roof tilted open, press and hold to close the roof. Releasing the switch will stop roof movement.

The sunroof will operate for 30 seconds after the ignition is turned off, provided that a front door is not opened.

5. Sun blind:
- To open, push upwards on the textured part of the handle. Then, slide the blind into the panel between the sunroof and the headlining.
 - To close the sun blind, pull across the aperture until it locks in place.

ONE-TOUCH WINDOW OPERATION

All four windows have one-touch operation. Briefly pull the switch up fully and release, the window will continue to raise until fully closed. Briefly press the switch down fully and release, the window will continue to lower until fully open. Pressing or pulling the switch again will stop the window.

WINDOW ANTI-TRAP PROTECTION



The anti-trap mechanism does not operate when closing the sunroof from the tilted position. The sunroof can cause serious injury should a body part become trapped. Always ensure that the sunroof is free from obstructions before closing.



Before closing a window or the sunroof, ensure that no occupants have any part of their body in a position where it could be trapped. Even with an anti-trap system death or serious injury could occur.

Anti-trap protection will stop window or sunroof movement if an obstruction or resistance is detected. Check the window or sunroof and its aperture and remove any obstructions (e.g. ice, etc.).

If it is still necessary to raise the window or close the sunroof, the override procedure is as follows:

1. Attempt to close the window/sunroof, anti-trap will prevent closure and lower the window/open the sunroof slightly.
2. Within ten seconds attempt to raise the window/close the sunroof again, anti-trap will prevent closure and lower the window/open the sunroof slightly.
3. Attempt to close the window/sunroof for a third time, this time hold the switch in the close position. Hold until closed.

Note: *If this procedure fails to remove the blockage, the window operation may need to be reset. See **190, WINDOW RESET**.*

Note: *The sunroof anti-trap mechanism works differently and does not require reset if activated. See **190, SUNROOF RESET**.*

EXTERIOR MIRRORS

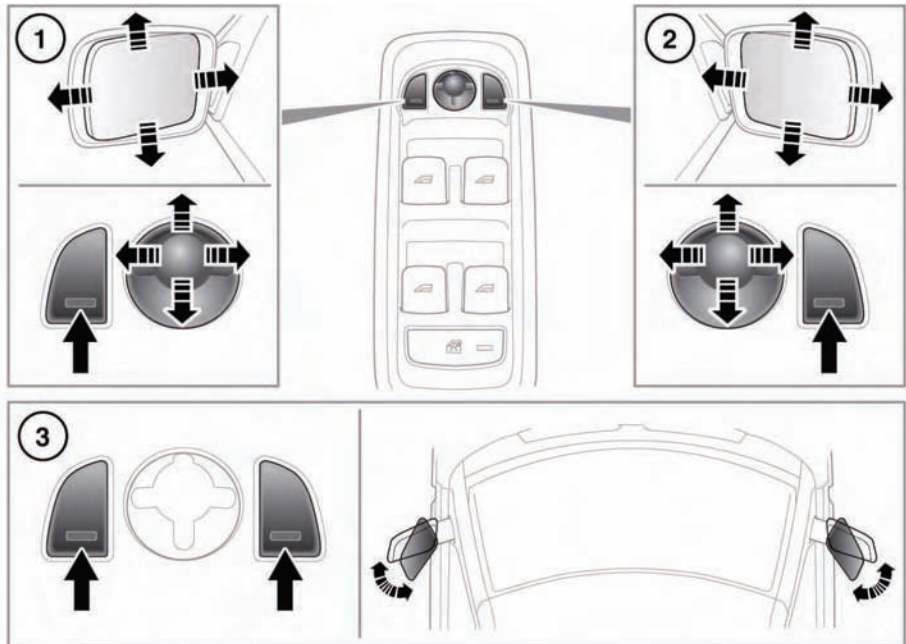

E134637

1. Left mirror adjustment.
2. Right mirror adjustment.
3. Press both switches together to fold/unfold the mirrors.

Note: If the mirrors are manually folded or knocked into the folded position accidentally, the mirror head will be loose. To re-engage the mechanism, fold, then unfold the mirrors using the switches.

A thermal cut-out which will temporarily disable the powerfold feature if the switches are operated repeatedly.

Powerfold will only operate if the vehicle is stationary, or travelling at 20 km/h (12 mph) or less.



The mirrors can be configured by your Dealer/Authorised Repairer to automatically fold when the vehicle is locked, and unfold when it is unlocked.

Note: If the mirrors were folded using the switches, they will not unfold when the vehicle is unlocked.

MIRROR DIP WHEN REVERSING

Selecting reverse gear will cause the door mirrors to automatically adjust, providing an improved viewing angle for reversing.



The exact dipped position can be adjusted when the mirrors are dipped. The next time reverse is selected, the newly adjusted position will be selected.

When the gear selector is moved out of reverse, the mirrors will return to their previous position.

Note: *If vehicle speed exceeds 7 km/h (4 mph) in reverse, the mirrors will return to their normal driving position for enhanced visibility.*

The automatic mirror dip feature can be enabled or disabled from the **Vehicle set-up** menu, see **52, INTERACTIVE CONTROLS**.

GARAGE DOOR TRANSCEIVER

-  **Do not use the transceiver with any garage door opener that lacks the safety stop and reverse feature as required by safety standards.**
-  **When programming the transceiver to a garage door opener or entry gate, ensure the area is clear. This will prevent potential harm or damage as the gate or garage door will activate during the programme.**
-  This device may suffer from interference if operated in the vicinity of a mobile or fixed station transmitter. This interference is likely to affect the hand-held transmitter as well as the in-car transceiver.

The door transceiver is located in the rear-view mirror. It can be programmed to transmit the radio frequencies of up to three different transmitters, which can be used to operate garage doors, entry gates, home lighting, security systems or other radio frequency operated devices.

Although this section mainly describes the procedures for a garage door opener, it equally applies to the previously mentioned applications.

In some countries, this feature is also known as the HomeLink[®] Universal Transceiver.

For further information, see **51, INFORMATION AND ASSISTANCE.**

BEFORE PROGRAMMING

-  When programming a device that may require you to press and re-press the hand-held transmitter (cycle), unplug the device during the cycling process to prevent possible motor failure.

For best results, fit a new battery to the hand-held transmitter of the garage door opener (or other device) before programming. If your garage door opener receiver (located in the garage) is equipped with an antenna, ensure that the antenna is hanging straight down.

PROGRAMMING

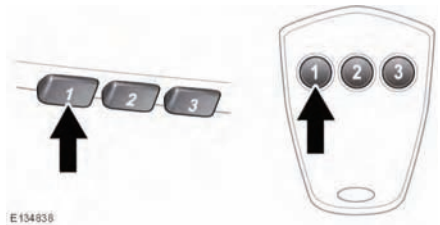

With the engine switched off;

1. Ensure that the ignition system is on.
2. Hold the end of the original garage door opener hand-held transmitter 50 to 150 mm (2 to 6 inches) away from the transceiver in the rear-view mirror, keeping the indicator lamp in view.
3. Using both hands, simultaneously press and hold both the chosen transceiver button on the rear-view mirror, as shown above, and the hand-held transmitter button. Keep both buttons pressed. The indicator lamp will flash slowly at first and then change to a fast flash. When the indicator lamp flashes rapidly, release both buttons. The rapid flashing lamp indicates successful programming.
4. If, after 60 seconds, the indicator lamp does not flash rapidly, release both the transceiver and the hand-held transmitter buttons and repeat the procedure starting with Step 2. Position the hand-held transmitter at a different angle and/or distance.

5. Press and hold the programmed garage door opener button and observe the indicator lamp.
 - If the indicator is continuous, programming is complete and your device should operate when the garage door opener button is pressed and held for approximately 1 to 2 seconds and then released.
 - If the indicator lamp blinks rapidly for two seconds and then illuminates continuously, proceed with the following programming instructions for rolling code device equipment.

TO ERASE ALL PROGRAMMING

For first time programming, ensure that the engine is switched off:

1. Ensure that the ignition is on (but with the engine switched off).
2. Press and hold the two outer buttons on the transceiver in the rear-view mirror. Keep the buttons pressed until the indicator lamp begins to flash (this will take approximately 20 seconds), then release the buttons.

All memories in the garage door opener have now been cleared.

Note: Do not perform this procedure when programming the additional garage door opener buttons.

ROLLING CODE DEVICE EQUIPMENT PROGRAMMING

Note: The assistance of a second person, may make the following steps quicker and easier. Once the button has been pressed there are only 30 seconds in which to complete Step 3.

1. At the garage door opener receiver (motor head unit) in the garage, locate the learn or smart button/switch.
 - The name of the button or switch may vary between manufacturers.
2. Press and release the learn or smart button.
3. Return to the vehicle and firmly press and hold the programmed garage door opener button for two seconds and release.
4. Repeat the press, hold, release sequence three times to complete the programming process.

The garage door opener in the rear-view mirror should now activate the rolling code device.

REPROGRAMMING A SINGLE GARAGE DOOR OPENER BUTTON

To programme a device to a previously programmed button:

1. Press and hold the desired pre-programmed garage door opener button for at least 20 seconds, but no longer than 30 seconds, until the indicator lamp begins to flash.
2. Without releasing the rear-view mirror button, position the hand-held transmitter approximately 50 to 150 mm (2 to 6 inches) away from the transceiver in the rear-view mirror, keeping the indicator lamp in view.
3. Carry out Step 3 of Programming.

ENTRY GATE PROGRAMMING

The technology of some entry gates requires you to press and re-press (cycle) the hand-held transmitter button every two seconds during programming.

Continue to press and hold the desired rear-view mirror button while you cycle your hand-held transmitter until the indicator lamp flashes rapidly.

INFORMATION AND ASSISTANCE



It is recommended that when you sell or dispose of the vehicle, the programmed transceiver buttons be erased for security purposes.

For information on the range of available compatible products or accessories, or for assistance, you should contact your Dealer/ Authorised Repairer.

You can also contact the supplier's helpline on **0 0800 0466 354 65**. This toll-free number can be called from anywhere within Europe. No separate country code is required (the first zero is not required when calling from within Germany).

Contact can also be made via the internet. The website address is www.eurohomelink.com.

The e-mail address is:

info@eurohomelink.com.

Note: *Keep the original transmitter for future use or programming procedures if, for example, you purchase a new vehicle.*

Note: *The manufacturer is not responsible for any radio or TV interference caused by unauthorised modifications to this equipment. Such modifications could void the user's authority to operate the equipment.*

INTERACTIVE CONTROLS

7. Access the vehicle service menu.

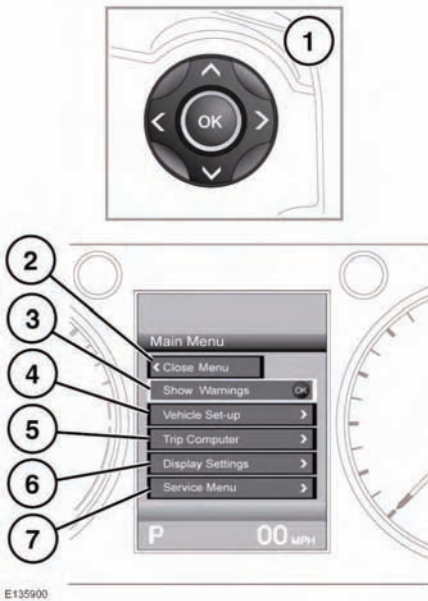

A number of vehicle features and display settings may be configured via the instrument panel menu.

1. Steering wheel menu control: Press any of the controls to activate the menu, then use as follows:
 - Press the up/down arrow to scroll up or down the list.
 - Press the right arrow to view a sublist.
 - Press the left arrow to return to the previous menu.
 - Press the **OK** button to select the highlighted item from a list.
2. Select to close the menu.
3. Show any warning messages.
4. Access the vehicle set-up menu.
5. Access the trip computer menu.
6. Access the display settings menu.

INSTRUMENT PANEL

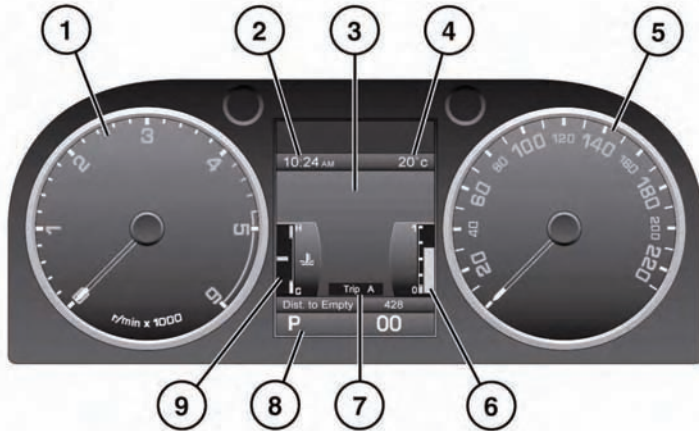

E134839

1. Tachometer.
2. Clock.
3. Message centre.
4. External temperature.
5. Speedometer.
6. Fuel gauge:
8. Gear selector position display.
9. Temperature gauge:

! Never allow the engine to run out of fuel. The resultant misfire can seriously damage the catalytic convertor.

If the amber low fuel warning lamp illuminates, the vehicle should be refuelled as soon as possible. The approximate distance that can be travelled on the remaining fuel can be viewed via the trip computer Distance to Empty function. See **58, TRIP COMPUTER**.

As a reminder for the location of the fuel filler, there is an arrow next to the fuel pump symbol pointing to the relevant side of the vehicle.

7. Total distance (odometer) and trip recorder.

! Serious engine damage can occur if the vehicle is driven while the engine is overheating.

If the pointer moves into the **H** section at the top of the scale, the engine is overheating. Stop the vehicle as soon as safety permits and allow the engine to idle until the temperature reduces. If, after several minutes, the temperature does not reduce, switch off the engine and allow to cool. If the problem persists, seek qualified assistance immediately.

Note: If engine overheating occurs, there may be a noticeable reduction in engine power and the air conditioning may cease operation. This is a normal operating strategy, to reduce load on the engine and assist with cooling.

Warning lamps

WARNING LAMPS AND INDICATORS

RED warning lamps are for primary warnings. A primary warning must be investigated immediately. Seek qualified assistance before continuing.

AMBER and **YELLOW** warning lamps are for secondary warnings. Some indicate that a vehicle system is in operation, others indicate that the driver must take action and then seek qualified assistance as soon as possible.

GREEN and **BLUE** lamps within the instrument panel indicate system status, such as green for direction indicators, when in operation and blue for high beam.

LAMP CHECK

A warning lamp bulb check is initiated when the ignition system is switched on and lasts for 3 seconds (except for the airbag warning lamp which will remain on for 6 seconds). If any warning lamp remains on after this period, investigate the cause before driving.

Some warning lamps have associated messages displayed on the message centre.

Note: *Not all warning lamps are included in the check (e.g. high beam headlamps and direction indicators).*

CRITICAL WARNING MESSAGE (RED)



Illuminates when a critical warning message is available in the message centre.

LOW OIL PRESSURE (RED)



Illuminates as a bulb check when the ignition is switched on and extinguishes when the engine is started. If the lamp remains on, flashes, or illuminates whilst driving, stop the vehicle as soon as safety permits and switch off the engine immediately.

Check and top-up the oil level if necessary. Start the engine: If the lamp remains illuminated, switch the engine off immediately and seek qualified assistance before continuing.

BRAKE (RED)



Illuminates briefly as a bulb check when the ignition is switched on. If the lamp illuminates whilst driving, suspect low brake fluid level or a fault with the Electronic Brake Distribution (EBD) system.

Stop the vehicle as soon as safety permits and check and top-up the brake fluid, if necessary. If the lamp remains illuminated, seek qualified assistance before continuing.

PARKING BRAKE (RED)



Illuminates when the parking brake is correctly applied. If the lamp flashes, a fault has been detected. Seek qualified assistance urgently.

BATTERY CHARGE (RED)



Illuminates as a bulb check when the ignition is switched on and extinguishes when the engine is started.

If the lamp remains on or illuminates whilst driving, there is a fault with the battery charging system. Seek qualified assistance urgently.

SEAT BELT (RED)



Illuminates when the ignition is on an occupied front seat belt is unbuckled. The lamp should extinguish when the relevant seat belt(s) is buckled.

BELTMINDER (RED)



If the vehicle is in motion and the driver's seat belt or an occupied front seat passenger's seat belt is unbuckled, the seat belt warning lamp will illuminate and a chime will sound.

Note: *The speed thresholds and the behaviour of the visual and audible warnings are dependent on market.*

ENGINE MALFUNCTION (AMBER)



Illuminates as a bulb check when the ignition is switched on and extinguishes when the engine is started.

If the lamp flashes or illuminates at any other time, there is a fault with the engine. Avoid high speeds and seek qualified assistance urgently.

GLOW PLUGS (AMBER)



Illuminates when the ignition is switched on to indicate that the glow plugs are active. Wait until the lamp extinguishes before starting the engine.

BRAKE (AMBER)



Illuminates briefly as a bulb check when the ignition is switched on. If the lamp illuminates after starting the engine or whilst driving, suspect worn brake pads or a fault with the Emergency Brake Assist (EBA) system.

The vehicle can still be driven with care, but seek qualified assistance urgently.

DYNAMIC STABILITY CONTROL (DSC) (AMBER)



Illuminates briefly as a bulb check when the ignition is switched on.

If the lamp flashes whilst driving, the DSC system is active.

DYNAMIC STABILITY CONTROL (DSC) OFF (AMBER)



Illuminates when DSC is switched off.

Warning lamps

ANTI-LOCK BRAKING SYSTEM (ABS) (AMBER)



Illuminates briefly as a bulb check when the ignition is switched on.

If the lamp remains on or illuminates whilst driving, there is a fault with the ABS system. Drive with care, avoiding heavy brake application and seek qualified assistance urgently.

AIRBAG (AMBER)



Illuminates as a bulb check when the ignition is switched on and extinguishes when the engine is started.

If the lamp illuminates when driving, there is a fault with the airbag system. Seek qualified assistance as soon as possible.

ADAPTIVE FRONT LIGHTING SYSTEM (AMBER)



Illuminates when there is a system fault. The headlamps will still operate, but without this feature operating correctly. Seek qualified assistance as soon as possible.

LOW FUEL WARNING (AMBER)



Illuminates when the remaining fuel reaches a minimum of 12 litres (3 gallons), giving an approximate range of 80 km (50 miles). Refuel at the earliest opportunity.

HIGH BEAM (BLUE)



Illuminates when the high beam headlamps are switched on or flashed.

AUTO HIGH BEAM (GREEN)



Illuminates when the auto high beam feature is enabled.

SIDE LIGHTS (GREEN)



Illuminates when the side lights are switched on.

FRONT FOG LAMPS (GREEN)



Illuminates when the front fog lamps are switched on.

REAR FOG LAMP (AMBER)



Illuminates when the rear fog lamps are switched on.

DIRECTION INDICATORS (GREEN)



The appropriate warning lamp will flash when the direction indicators are operated.

CRUISE CONTROL (GREEN)



Illuminates when cruise control is active.

TYRE PRESSURE MONITORING SYSTEM (YELLOW)



Illuminates when one or more tyres are significantly under-inflated. Stop the vehicle as soon as possible, check the tyre pressures and inflate to the recommended pressure.

HILL DESCENT CONTROL (GREEN)



Illuminates continuously when HDC is selected and HDC operating conditions are met - i.e. vehicle speed below 50 km/h (30 mph).

If the lamp flashes, HDC has been selected, but the operating conditions are not being met (e.g. vehicle speed is too high) or HDC fade-out is occurring.

LOW RANGE (GREEN)



Illuminates when Low range has been selected.

TRAILER DIRECTION INDICATORS (GREEN)



Illuminates as a bulb check when the ignition is switched on and extinguishes when the engine is started.

If a trailer is attached, the warning lamp will flash in conjunction with the direction indicator warning lamp. If the lamp fails to flash, the direction indicator bulb on the trailer may be faulty.

WARNING AND INFORMATION MESSAGES



Do not ignore warning messages. Take appropriate action and, when necessary, seek qualified assistance before driving the vehicle.

If more than one message is active, each is displayed in turn for 2 seconds in order of priority.

***Note:** The message centre messages and their meanings, are detailed where necessary within the appropriate subject sections.*

TRIP COMPUTER

The computer memory stores data for a journey or series of journeys until it is reset to zero.

The displayed information is for guidance only, as it can be affected by traffic, road and weather conditions.

Three independent memories are available, A, B and Auto. A and B memories can be reset independently, while the Auto trip will reset after every ignition cycle as the vehicle moves.

Trip computer information is displayed on the instrument panel.

USING THE TRIP COMPUTER

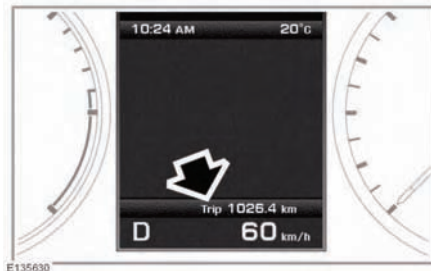

A short press (1 second or less) or a series of short presses of the **i** button will change the trip computer display.

The options available are:

- Odometer.
- Trip distance.
- Trip average speed.
- Trip average fuel consumption.
- Instantaneous (short term average) fuel consumption.
- Range available from remaining fuel.
- Blank display.

To reset the trip computer values to zero, press and hold the **i** button for 2 seconds.

To reset the fuel consumption figure, press and hold the **i** button until the display clears.

There are 3 trip memories available, A, B and Auto. You can specify which trip memory is viewable using the **i** button.

To reset trip A or trip B memory, display the trip memory you wish to reset and press and hold the **i** button until the message **Resetting Trip A** or **B** is displayed. Continue to hold the button for another 2 seconds to reset the Auto trip memory.

The Auto trip memory also resets automatically each time the engine is started and the vehicle moves.

Trips may be added together to record a continuous journey. Press the **i** button when Auto memory figures are displayed, and **Adding previous journey** will appear on the screen. Press the **i** button for longer than 1 second, and previous trip information will be added to the current trip and the cumulative total displayed.

If you wish to delete the trip you have added, again press the **i** button while displaying the Auto memory figures. Deleting previous journey will appear on the screen. While this message is displayed, press and hold the **i** button for longer than 1 second. The previous trip will be deleted from the total.

TRIP DISTANCE

Distance travelled since the last memory reset. The maximum trip reading is 9 999.9 (kilometres or miles). The computer will automatically reset to zero if this distance is exceeded.

RANGE

This shows the predicted distance, miles or kilometres, that the vehicle should travel on the remaining fuel, assuming fuel consumption stay constant.

METRIC/IMPERIAL/MIXED DISPLAY

The trip computer readings can be changed between metric, imperial and mixed units in the **Trip Computer** menu of the message centre. See **52, INTERACTIVE CONTROLS**.

Note: Temperature display can be changed between °C (Celsius) and °F (Fahrenheit) independently of Metric or Imperial units.

SERVICE INTERVAL INDICATOR

The service interval message will only be displayed when the vehicle has less than 3200 km (2000 miles) before the service is due.

When the ignition is switched on, and the vehicle has started its service countdown, **SERVICE REQ'D XXXX km (XXXX MLS)** is displayed in the message centre.

When the service distance has been reached, **SERVICE REQUIRED** is displayed in the message centre.



If no service interval indicator is displayed during the vehicle service cycle, make sure that your vehicle is serviced in accordance with the intervals, as stated in the Service Portfolio.

Heating and ventilation

FRONT CLIMATE CONTROL

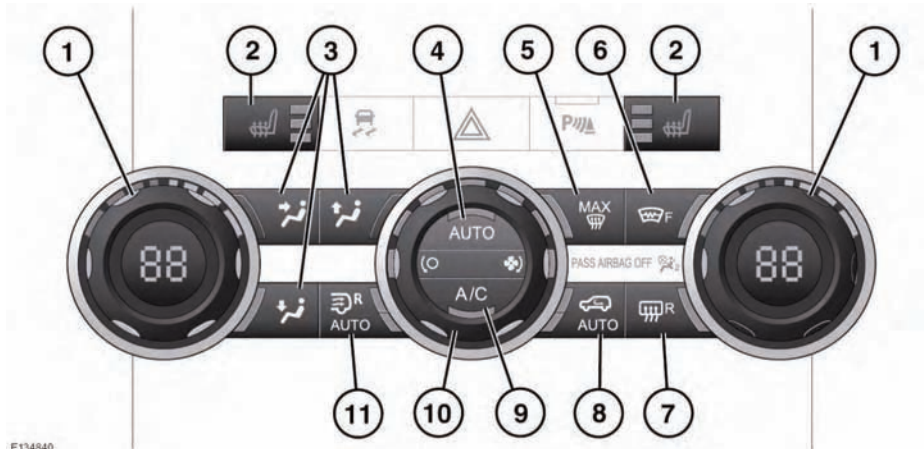

E134840

1. Temperature controls.
2. Seat heaters: Press once to turn on high, twice to turn on low, and a third time to turn off.
3. Air distribution buttons.
 - Windscreen and side window vents.
 - Face level vents.
 - Foot level vents.

Note: More than one setting may be selected at a time to achieve the desired distribution.
4. Auto mode.
5. Maximum defrost mode.
6. Heated front windscreen.
7. Heated rear screen.
8. Air recirculation control
9. Air conditioning on/off: With air conditioning off, the system operates in economy mode, improving fuel economy.

Note: Using the system without air conditioning for long periods can cause the windows to mist.

10. Blower control: Rotate to adjust blower speed.

Rotate fully anticlockwise to turn the climate control system off.
11. Rear environment.
 - Press once to control the rear heating and air conditioning using the front controls only. The lower amber lamp is illuminated.
 - Press a second time to allow the rear passengers to have manual control. The upper amber light is illuminated. See **61, REAR CLIMATE CONTROL**.
 - Press a third time to switch off.

Note: The indicator lights in the switches will illuminate when the function is selected.

Note: In low temperatures it is advisable to close the centre face level vent and direct air flow from the outer face level vents towards the side windows. This will help to keep the windows clear of ice.

AUTOMATIC CLIMATE CONTROL

Press **AUTO** to select automatic operation.

The system will adjust the heat output, blower speed, air intake and airflow distribution to maintain the selected temperature(s) and reduce misting without further adjustments.

The air distribution and blower controls may be operated independently to override Auto mode. If you do this, the indicator lamp on the AUTO switch will go out. Press **AUTO** again to return to automatic operation.

Note: The system will not achieve a temperature differential from left to right of more than 4°C (7°F).

RECIRCULATION



When selected, the air is recirculated inside the vehicle. This helps to maintain a high or low temperature, and is useful for preventing fumes entering the vehicle.

Note: The windows can mist if recirculation is used for long periods.

AIR QUALITY SENSOR



Press once to activate air recirculation. Press again to activate automatic air recirculation.

In automatic mode, air recirculation is regulated to achieve optimum air conditioning performance.

Press a third time to switch off.

Note: The windows can mist if recirculation is used for long periods.

HEATED SCREENS



Heated windscreen.



Heated rear screen.

Press button to operate the required screen heater. The screen heater(s) will operate for a predetermined timed period before automatically switching off.

The screen heaters will be automatically switched on if defrost mode is activated or if the external air temperature is low.

 Do not attach labels to the rear screen. Do not scrape or use abrasive materials to clean the inside of the screen.

REAR CLIMATE CONTROL

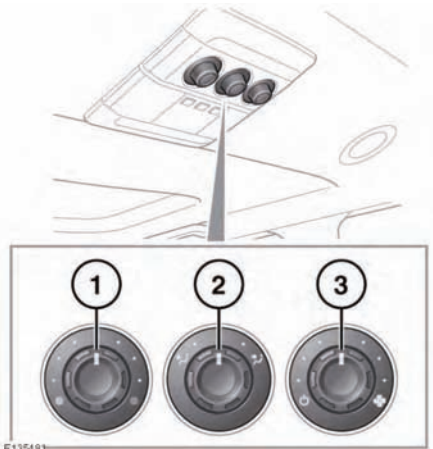

1. Temperature control: Rotate clockwise to increase the temperature.
2. Distribution control: Rotate to the relevant icon to direct airflow.

Heating and ventilation

The control may be turned to a position between icons to split airflow between different vents.

3. Blower control: Rotate to the desired setting.

Note: These controls only operate when the rear environment button is pressed twice, enabling rear manual operation.

AUXILIARY HEATER

Your vehicle may be fitted with an auxiliary heater which is powered by fuel drawn from the vehicle's tank. The heater only operates at low ambient temperatures, and is controlled by the Timed climate control system.

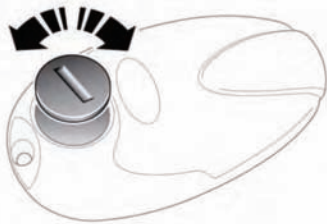
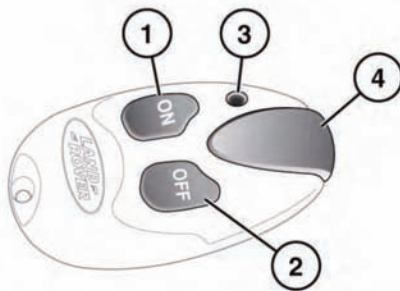

E134924

The remote control has an approximate range of 1000 m. There is no need to point the antenna at the vehicle.

1. On button.
2. Off button.

3. LED (operation indicator).
4. Antenna.

Note: Avoid touching the antenna when operating the **ON** or **OFF** button.

When the heater is operating exhaust fumes from the heater may be visible exiting from under the front of the vehicle. This is normal, and not a cause for concern.



Do not operate the auxiliary heater when refuelling the vehicle. Doing so may cause fuel vapours to combust causing a fire/explosion.



Do not operate the auxiliary heater whilst the vehicle is in an enclosed space. Doing so can cause a build up of highly toxic fumes which may cause unconsciousness or death.

REPLACING THE BATTERIES

With the back of the remote control facing upwards, use a coin or similar implement to rotate the battery cover. Lift the cover off to reveal the battery compartment. Remove the old battery and, ensuring that the correct polarity is maintained, insert a replacement 3.3 volt, CR1/3N battery. Replace the cover and rotate it to lock it closed.

TIMED CLIMATE CONTROL

The system provides a comfortable temperature inside the cabin in advance of driver and passengers entering. Dependent on the external temperature, the system draws in fresh air to cool the cabin, or operates the auxiliary heater to warm it.

The auxiliary heater is also operated to warm the engine and aid starting in very cold conditions.

The timed climate control system may be operated by either the touch screen or the remote handset.

SWITCHING ON

Press and hold the **ON** button for approximately two seconds. The LED will illuminate to confirm that an automatic heating program has been initiated. The LED flashes once every 2 seconds to indicate that the heater is active.

The heating program will continue for 30 minutes, when it will switch off automatically to prevent the vehicle battery from discharging. It also turns off automatically if the engine is started.

The system may not operate, or will switch off automatically, if:

- If the fuel level is low.
- If the vehicle's battery charge is low.
- If the coolant temperature is at or above its required temperature.

The LED indicator, contained in the remote control, signals various states and conditions for the heater as follows:

- Illuminates green for 2 seconds when the **ON** button is pressed, to indicate that heater operation has been requested.
- Illuminates red for 2 seconds when the **OFF** button is pressed, to indicate that the heater has stopped.
- Flashes green or red for 2 seconds when the on or off buttons are pressed, to indicate that the signal was not received.
- Illuminates orange for 2 seconds before showing green or red, to indicate that the remote battery is low.
- Flashes orange for 5 seconds to indicate that the signal was not received and the remote battery should be replaced.

ADDITIONAL REMOTES

Additional remote controls can be programmed to operate the heater. A maximum of 3 remotes can be programmed to each vehicle. You should contact your Land Rover Dealer/Authorised Repairer to purchase additional remotes and have them programmed to your vehicle.

USING THE TOUCH SCREEN

The touch screen can be used to either program preset activation times for the timed climate control system, or to operate the system manually. The system can be programmed to operate once or twice in any 24 hour period. If the vehicle is used after each activation, the system will continue to operate until cancelled. If the vehicle is not used before the second activation, system operation will be suspended.

Note: *When activated, the heating program will operate for 20 minutes at ambient temperatures of -20 °C (-4 °F) and above, or for 30 minutes at ambient temperatures below -20 °C (-4 °F). Then the heating program automatically switches off, to prevent the vehicle battery being discharged.*

The system can be programmed to operate once or twice in any 24 hour period. If the vehicle is used each day the system will continue to operate each day until cancelled. If the vehicle is not used for 24 hours, this cycle will be cancelled.

Note: *Operation of timed climate control will resume the next time the ignition is turned on.*

When the system is operating, the LED in the AUTO button will flash.

Note: *The system will cease operation if the engine is started.*

SETTING A TIME FOR TIMED CLIMATE OPERATION

To preset a time for Timed climate operation:

1. On the touch screen Home menu, select **Extra features** then **Timed climate**.
2. Select the power on/off icon under the timer you would like to program.
3. Select the day(s) that you want Timed climate to operate.
4. Use the up and down arrows to set the time you want the system to begin operation.
5. Select **OK**. The screen will now show the time at which the system is set to activate. If required, set the time for the other timer using the same process.

A previously set time may be cancelled by pressing the power on/off icon, for all times set in Timer 1 or Timer 2 on the Week view screen, or for a specific timer on the individual timer set screens.

Note: *The time format shown is determined by the time settings currently selected in the **System settings** menu. See **116**.*

STORAGE COMPARTMENTS

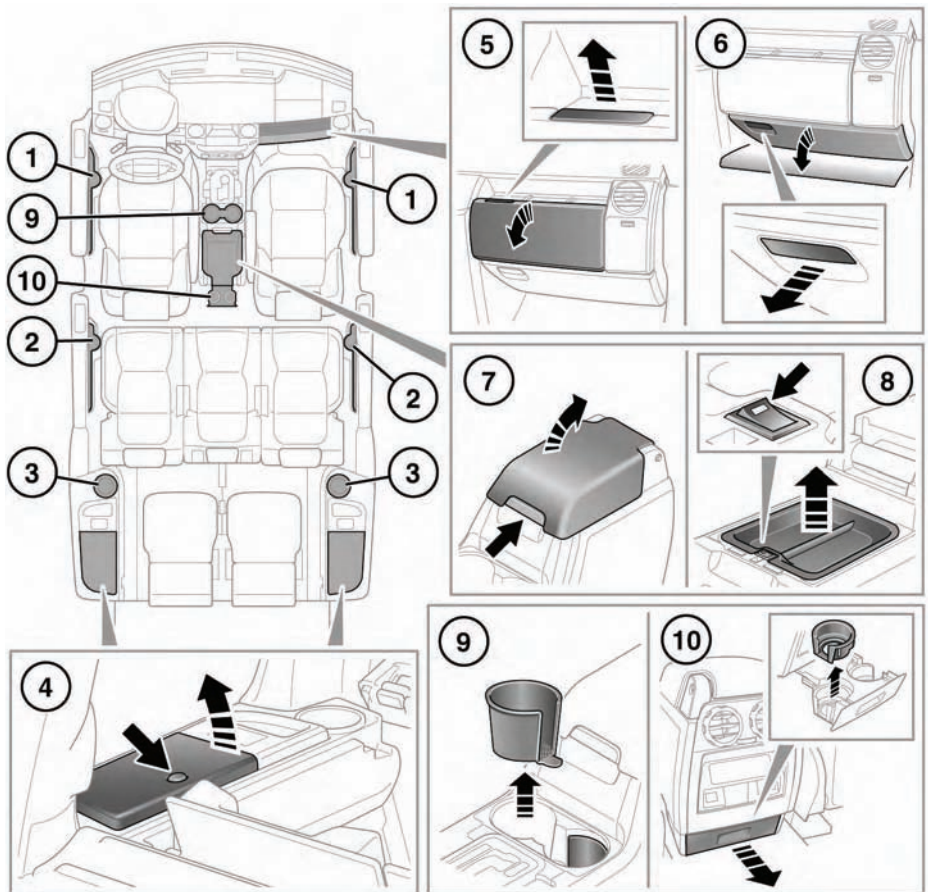

E134845



Ensure that any items stored in the vehicle are secure and cannot move. If the vehicle is involved in an accident, or subject to sudden braking or direction change, loose items can cause serious injury.



Do not drink, or use the cup holders when driving.

1. Door bottle holders.
2. Second row seat cup holders.
3. Third row seat cup holders.
4. Rear storage bins.
5. Glovebox.
6. Lower glovebox.

Storage compartments

7. Centre console storage: The rubber mat at the bottom of the centre console is designed to hold CD cases.

8. Cool box: Switch on and off using the switch on the inside front lip. There is a short delay between pressing the switch and illumination of the indicator.

The cool box will work best when the cooling tray is used.

Note: *The cool box will only operate with the ignition turned on.*



The cool box should be switched off when it is not needed to preserve battery charge.

9. Centre console cup holders.

10. Second row seat cup holders.

AUXILIARY POWER SOCKETS

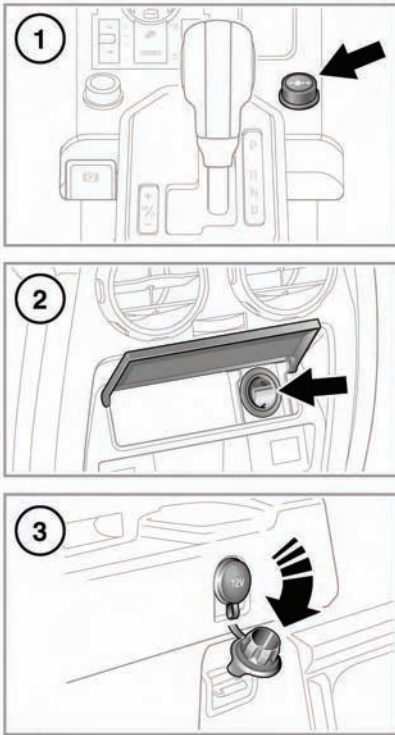

E137113

1. Front power socket.
2. Second row power socket.
3. Loadspace power socket.

 Only use Land Rover approved accessories. Using any other equipment may damage the vehicle's electrical system. If you are in any doubt contact a Land Rover Dealer/Authorised Repairer.

 The engine should be running when using accessories for long periods. Failure to do so can discharge the battery.

Note: Power sockets can be used to power approved accessories that use a maximum of 180 Watts.

Load carrying

LOADSPACE COVER

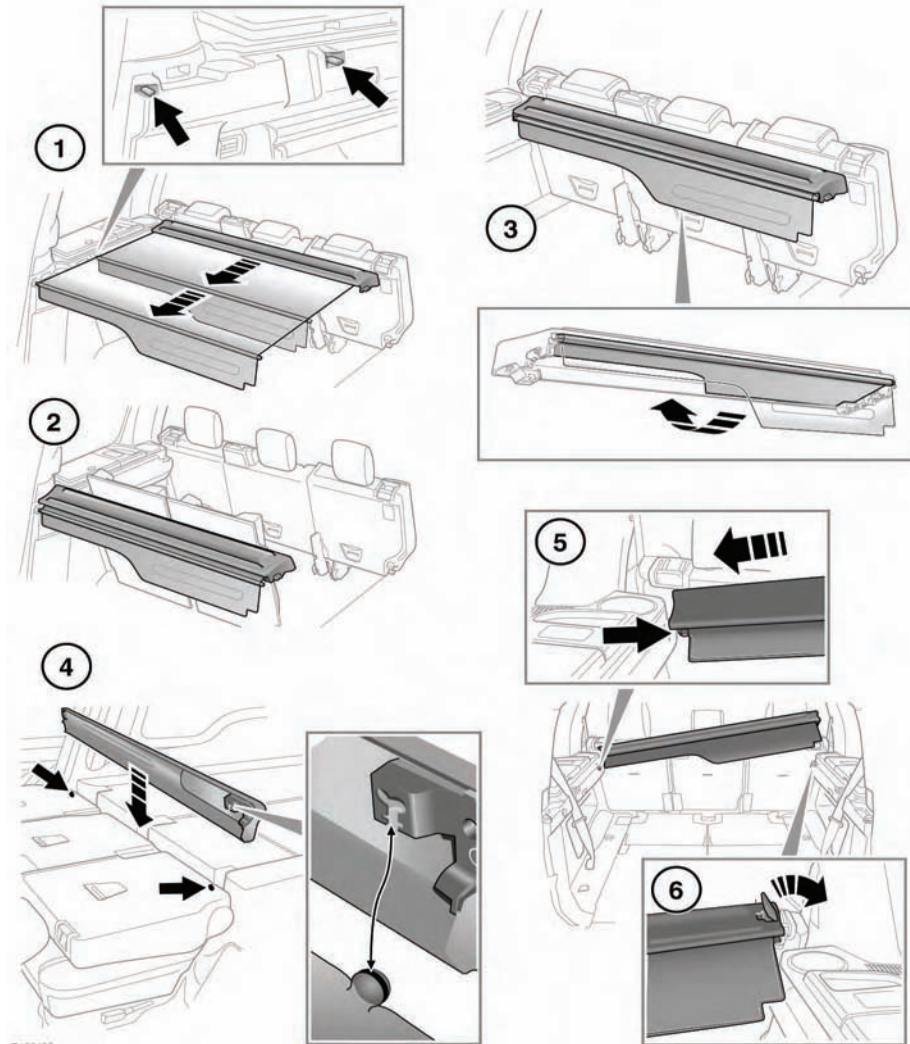

E135482



Never place objects on top of the loadspace cover. During an accident or sudden maneuver, loose objects can cause serious injury or death.

1. Pull the rigid portion of the cover to unroll. Engage the end pieces into the recessed features moulded into the loadspace sides.

2. The loadspace cover can be fitted in two positions. The foremost fitting is close behind the second row of seats; the rearmost is behind where the third row of seats are/would be fitted
3. To retract the loadspace cover, disengage the ends from the recessed areas and allow the soft portion of the cover to retract into its housing. Fold the rigid portion back under the unit and press to clip in place.
4. In the 7 seat vehicle only, the loadspace cover may be stowed behind the second row seats when not in use. See **19, FOLDING THE SEATS (7 seat vehicle)** for more details of loadspace cover stowage.



Never place the loadspace cover behind the second row of seats, if the third row is to be occupied.



Remove the stowed loadspace cover before moving the seats.



Do not attempt to raise the second row seats into the upright position, or tip them forward for third row access, while the loadspace cover is stowed behind the second row, as damage will result.

In 5 seat vehicles, the cover must be removed from the vehicle altogether if not in use.

5. To remove the loadspace cover, first pull up the paddle at the right hand end of the cover.
6. Lift the right hand end of the unit and pull away from the left hand side.

Note: It is easier to remove/refit the loadspace cover if the second row seat backs have been tipped forward.

Note: Installation of the loadspace cover is the reverse of removal.



When fitting the loadspace cover in position, ensure that the paddle returns to the flush (horizontal) position. Failure to do so may allow the loadspace cover to move during an accident or sudden maneuver.



Do not store the loadspace cover loose in the vehicle. During an accident or sudden maneuver, the load space cover could cause serious injury or death.

LUGGAGE ANCHOR POINTS

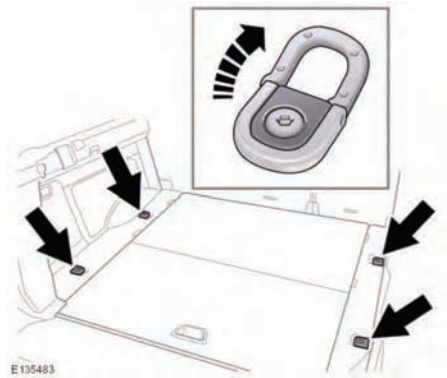

To assist in safely securing large items of luggage, four fixing points are located in the rear loadspace floor.



All items carried in the loadspace area should be properly secured. If the vehicle is involved in an accident, subject to sudden braking or change of direction, loose items can cause serious injury.

Note: A range of approved luggage retention accessories are available from your Land Rover Dealer/Authorised Repairer.

TOWING WEIGHTS

| Maximum permissible towing weights | |
|------------------------------------|---------------------|
| Unbraked trailers | 750 kg (1650 lbs) |
| Trailers with overrun brakes | 3500 kg (4400 lbs)* |
| Nose weight | 150 kg (330 lbs) |
| Nose weight - Australia only | 350 kg (770 lb) |

* For diesel vehicles in Algeria, Egypt, India, Libya, Morocco, Pakistan and Tunisia, the maximum permissible towing weight for a trailer with overrun brakes is 1500 kg (3307 lbs).

See **202, WEIGHTS**, for details of the Gross Vehicle Weight (GVW), Gross train weight, axle weights and maximum payload.

Note: When towing, the maximum permissible Gross Vehicle Weight can be increased by a maximum of 100 kg (220 lbs) provided that the road speed is limited to 100 km/h (60 mph).

Note: When calculating rear axle loading, remember that the trailer nose weight, the load in the vehicle's luggage area, weight on the roof rack, and the weight of rear seat passengers must all be added together.

TRAILER ELECTRICAL CONNECTION

 Only connect approved electrical circuits, which are in good condition, to the trailer socket.



When a trailer electrical connection is made, and the vehicle's direction indicators are used, the trailer warning lamp will flash in time with the direction indicators.

TOWING A TRAILER



Never exceed the maximum weights for either the vehicle, or the trailer. Doing so can cause accelerated wear and damage to the vehicle. It can also adversely affect vehicle stability and braking which in turn can lead to loss of control and increased braking distance, resulting in a rollover or crash.



To preserve handling and stability, only fit Land Rover approved towing accessories.



Never use towing eyes or lashing points to tow a trailer. They have not been designed for this purpose and doing so may cause them to fail, resulting in injury or death.



To avoid overheating the gearbox (and the clutch on manual vehicles), it is not advisable to tow heavy trailer loads at speeds of less than 32 km/h (21 mph) in High range. Select Low range instead.

ESSENTIAL TOWING CHECKS

- When calculating the laden weight of the trailer, remember to include the weight of the trailer, plus the weight of the load.
- If the load can be divided between the vehicle and trailer, loading more weight into the vehicle will generally improve stability. Do not exceed the vehicle's weight limits.
- To maintain vehicle stability, it is essential that the trailer is loaded so that it remains parallel to the ground. This is particularly important when towing twin axled trailers.
- Increase rear tyre pressures of the towing vehicle to those for maximum vehicle loading conditions.

- Ensure trailer tyre pressures are set to trailer manufacturer's recommendations.
- If the vehicle is loaded to maximum Gross Vehicle Weight (GVW) the nose weight is limited to 150 kg (330 lbs). See **202, WEIGHTS**.
- If it is necessary to increase the nose weight up to a maximum of 250 kg (550 lbs), the vehicle load should be reduced accordingly. This ensures that the GVW and maximum rear axle load are not exceeded.
- Ensure that a suitable breakaway cable or secondary coupling is used. Refer to the trailer manufacturer's instructions for guidance.
- Ensure that the tow ball is secure.
- Check the operation of all trailer lights.



Do not loop the breakaway cable over the tow ball as it may slide off.



Do not exceed the Gross Vehicle Weight (GVW), maximum rear axle weight, maximum trailer weight, or nose weight. Exceeding any of these limits could cause instability and loss of control.

Australia only:

- **Tyre pressures** - Increase rear pressures of towing vehicle to those for maximum Gross Vehicle Weight conditions.
- **Nose weight** - Must be a minimum of 7% of gross caravan/trailer weight, up to a maximum of 350 kg (722 lb).
- **Hitch height** - Must be set with the engine running, so that the caravan/trailer is level when connected to the vehicle.

TOW BALL/DRAWBAR STOWAGE



The tow ball/drawbar receiver is heavy, care must be taken when handling it. When the ball locks into position, the locking lever can snap back under spring pressure, take care not to catch your fingers.

5 seat vehicles: The tow ball/drawbar receiver is stowed under the loadspace floor.

7 seat vehicles: The tow ball/drawbar receiver is stowed behind an access cover on the left hand side of the loadspace.

FITTING THE DETACHABLE TOW BALL

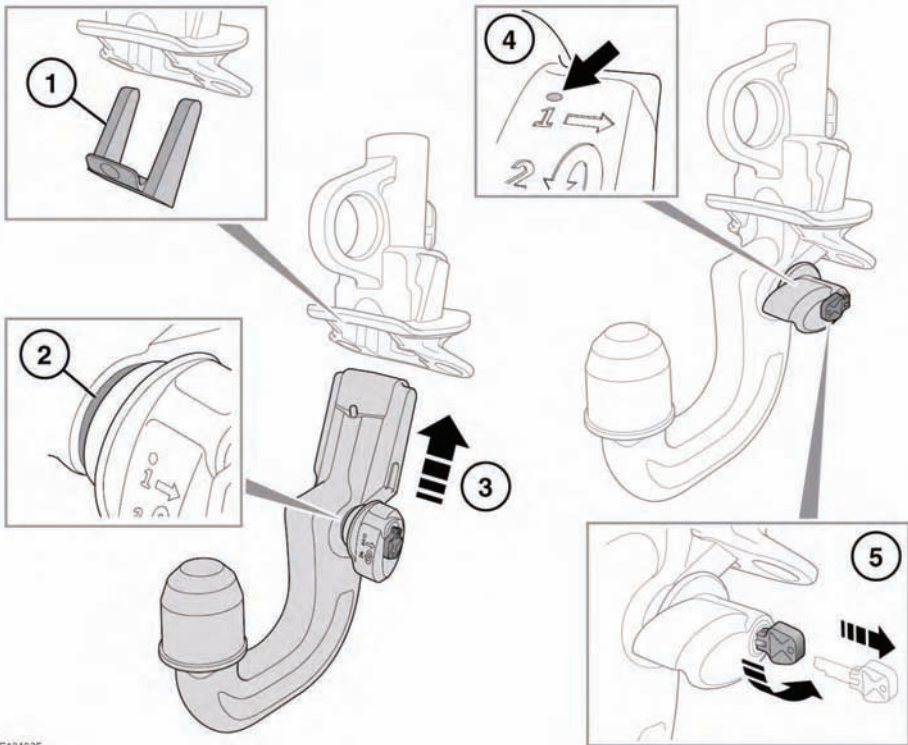

E134925

1. Remove the protective cover from the tow ball and stow it in the tow ball stowage area.
2. The tow ball can only be installed when the green locking lever is in the unlocked position.
3. Insert the tow ball into the mounting and push firmly upwards until the tow ball locks into position.
4. The red marker must be completely covered by the green locking lever.
5. Turn the key counterclockwise to lock the tow ball and remove the key before towing.

REMOVING THE DETACHABLE TOW BALL

Removal of the tow ball is the reverse of fitting.

Note: The key cannot be removed when the tow ball has been detached.

FITTING THE DETACHABLE DRAWBAR RECEIVER (Australia only)

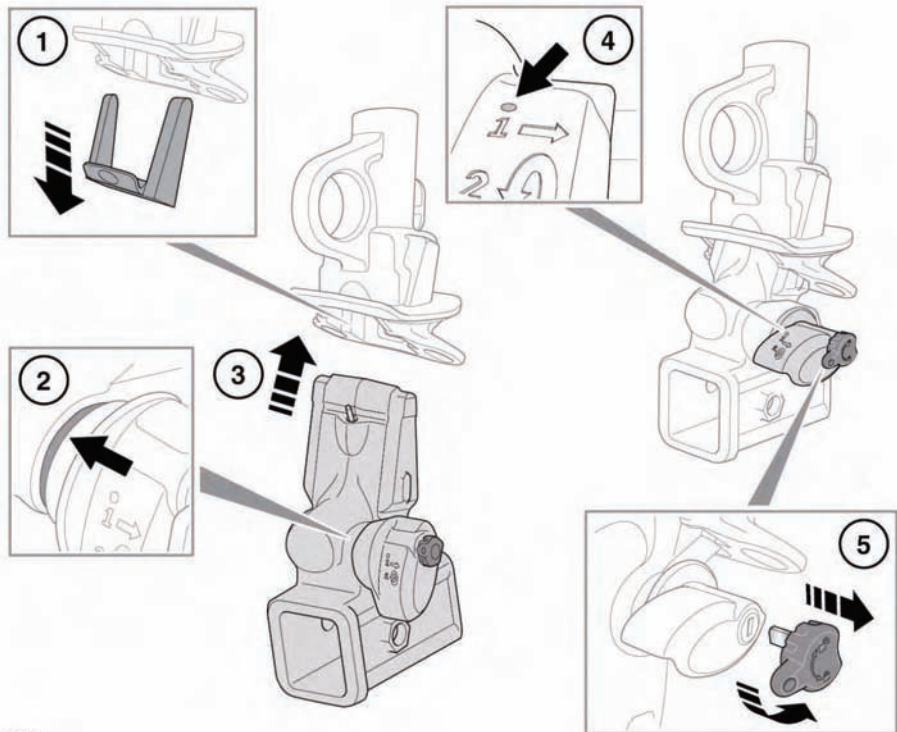

E134930

1. Remove the protective cover from the vehicle mounting and stow it into the drawbar receiver storage area.
2. The receiver can be installed only when the green locking lever is in the unlocked position.
3. Insert the receiver into the vehicle mounting and push firmly upwards until it locks into position.
4. The red marker must be completely covered by the green locking lever.
5. Unfold the key and turn it anticlockwise to lock the receiver, before inserting a drawbar. Remove the key and store in a safe place.

REMOVING THE DETACHABLE DRAWBAR RECEIVER

Removal of the drawbar receiver is the reverse of fitting.

Note: The key cannot be removed when the drawbar receiver has been detached.

TRAILER HITCH (Australia only)

The optional trailer hitch (drawbar) receiver is rated as a Class III.

When selecting a drawbar for the receiver, the following dimensions must be adhered to:

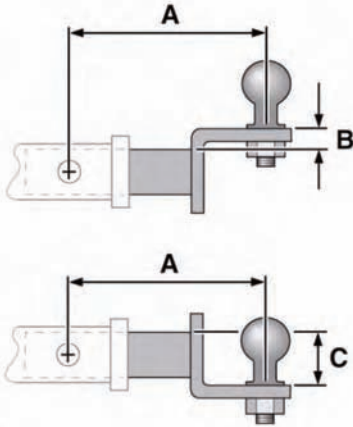

E134931

- A.** The maximum recommended drawbar length is 152 mm (6 in.).
- B.** To achieve the maximum ball height, a drawbar with a rise of 25.4 mm (1 in.) is recommended.
- C.** To achieve the minimum ball height, a drawbar with a drop of 60 mm (2 3/8 in.) is recommended.

Consult your Land Rover Dealer/Authorised Repairer for the latest information.

TOW BALL AND MOUNTING POINT DIMENSIONS (Fixed tow ball)

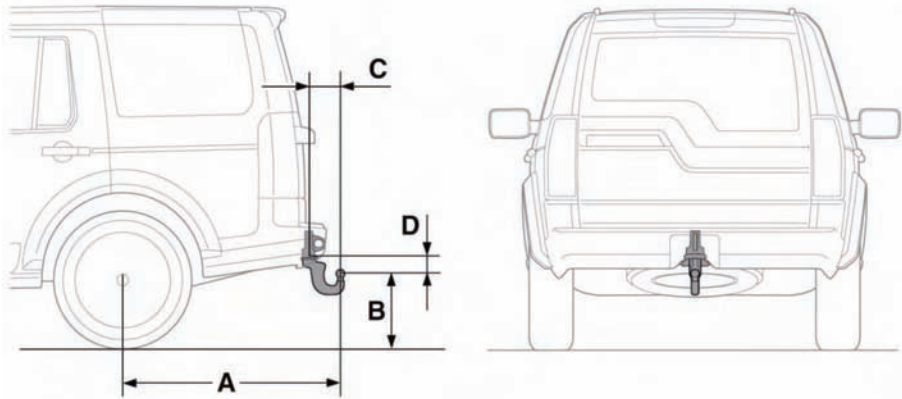

E134934

| Ref. | Dimension | Metric | Imperial |
|------|--|----------|----------|
| A | Wheel centre to centre of tow ball | 1,190 mm | 46.9 in. |
| B | Ground to centre of tow ball | 409 mm | 16.1 in. |
| C | Centre of tow ball to tow bar attachment | 170 mm | 6.7 in. |
| D | Centre of tow ball to tow bar attachment | 124 mm | 4.9 in. |

Note: Dimensions refer to towing equipment officially released by Land Rover.

Note: Australia only: The optional drawbar has significantly different dimensions and is rated as a Class III. See **74, TRAILER HITCH (Australia only)**.

TOW BALL AND MOUNTING POINT DIMENSIONS (Multi-height drop plate)

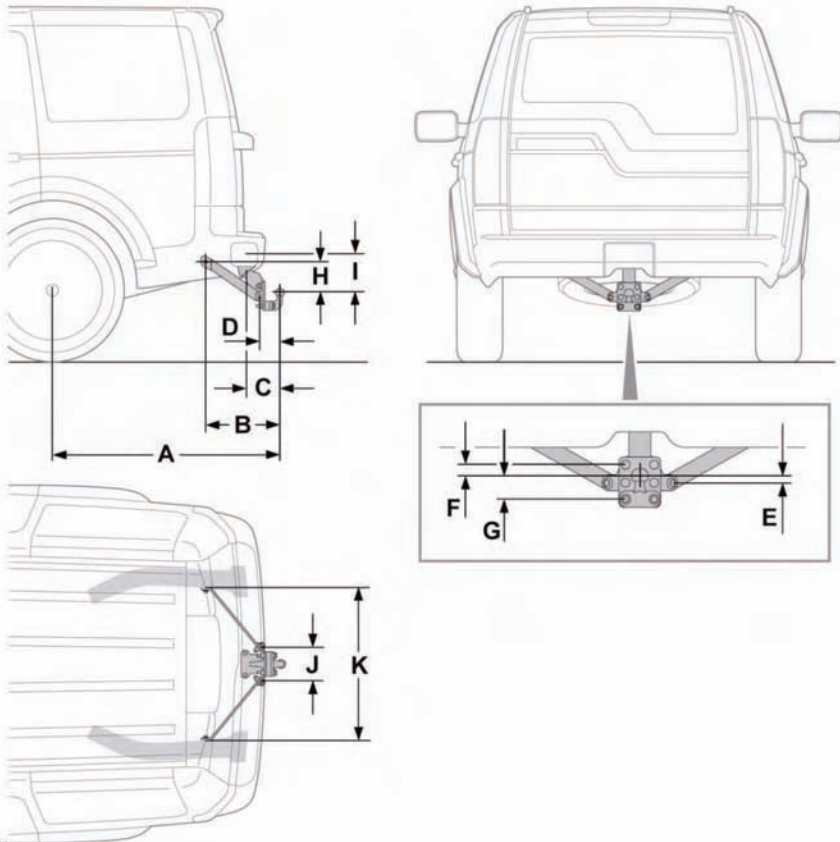

E134936

| Ref. | Dimension | Metric | Imperial |
|------|--|----------|-----------|
| A | Wheel centre to centre of tow ball | 1,210 mm | 47.64 in. |
| B | Centre of outer attachment points to centre of tow ball (horizontal) | 403.6 mm | 15.89 in. |
| C | Centre of housing bayonet slot tip radius to centre of tow ball | 192.4 mm | 7.57 in. |
| D | Centre of inner attachment points to centre of tow ball (horizontal) | 124 mm | 4.9 in. |

| Ref. | Dimension | Metric | Imperial |
|-------------|---|---------------|-----------------|
| E | Centre of inner attachment points to centre of tow ball (vertical) | 20 mm | 0.79 in. |
| F | Centre of upper tow ball plate bolt to centre of tow ball (vertical) | 36 mm | 1.42 in. |
| G | Centre of lower tow ball plate bolt to centre of tow ball (vertical) | 70 mm | 2.76 in. |
| H | Centre of outer attachment points to centre of tow ball (horizontal) | 167.3 mm | 6.59 in. |
| I | Centre of line housing bayonet slot tip radius to centre of tow ball (vertical) | 174.3 mm | 6.86 in. |
| J | Distance between inner attachment point centres | 180.5 mm | 7.10 in. |
| K | Distance between outer attachment point centres | 822.5 mm | 32.38 in. |

Starting the engine

STEERING COLUMN LOCK

 During vehicle recovery, the Smart Key must remain inside the vehicle, so that the steering column remains unlocked.

Your vehicle is fitted with an electronic steering column lock. The column unlocks when a Smart Key is detected inside the vehicle.

If any malfunction of the steering column lock occurs, **STEERING COLUMN LOCKED** will be displayed in the message centre. If this occurs:

1. Lock and then unlock the vehicle using the Smart Key.
2. Try again to unlock the steering column lock, by turning the steering wheel gently to the left and right.
3. If the problem persists, seek qualified assistance immediately.

SWITCHING ON THE IGNITION

To turn on the ignition without starting the engine. Ensure the brake pedal is not depressed, and with a valid Smart Key present in the vehicle, press the START/STOP button and hold until the warning lamps illuminate, then release the button.

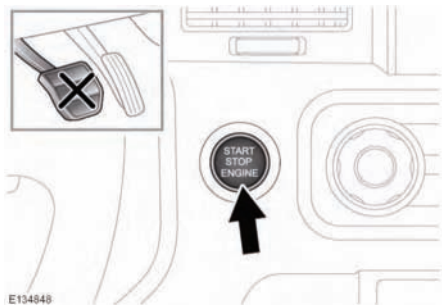

 If the brake pedal is applied when the start/stop button is pressed, the engine will start.

STARTING A PETROL ENGINE

 **Never start the engine and leave it running when the vehicle is in an enclosed space. Exhaust gases are poisonous and can cause unconsciousness and death if inhaled.**

To start the engine:

- The Smart Key must be inside the vehicle.
- **P** or **N** must be selected.
- Apply the brake pedal.
- Press and release the START/STOP button.

Once the engine has started, the brake pedal can be released if it safe to do so.

STARTING A DIESEL ENGINE

Diesel engine models may have an additional delay of up to 12 seconds between the START/STOP button being pressed and the engine starting. During this delay period, keep the brake pedal depressed and do not press the START/STOP button a second time. Doing so will cancel the starting procedure.

Note: *In very cold conditions it is normal for the engine cranking time to be increased.*

IF THE ENGINE FAILS TO START

Note: If the engine fails to crank when the START/STOP button is pressed, and there has been a recent collision, the fuel system inertia switch may have been tripped. Seek qualified assistance.

Petrol engines: If the engine persistently fails to start, make sure the transmission is in **P** and press the START/STOP button (without applying the brake pedal) to switch on the ignition. Slowly depress the accelerator pedal fully, then hold it in the fully down position and press the START/STOP button with the brake pedal applied. The engine will then begin to crank. Release the accelerator pedal when the engine starts.

If the engine fails to crank, or fails to start, consult your Dealer/Authorised Repairer.

Diesel engines: If the engine persistently fails to start, make sure the transmission is in **P** then press the START/STOP button (with the brake pedal applied). Keep the START/STOP button and the brake pedal pressed until the engine starts, then release.

If the engine still fails to crank, or fails to start consult your Dealer/Authorised Repairer.

If the vehicle has been unlocked using the emergency key blade or the Smart Key is not detected by the vehicle, it will be necessary to use the keyless start backup to disarm the alarm and start the engine.

The keyless start backup can only be used when the message **Smart Key Not Found Place As Shown** is displayed in the message centre.

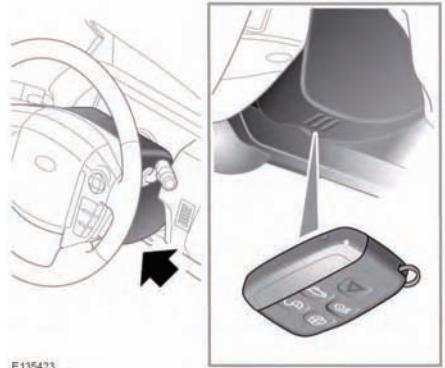

Position the Smart Key against the underside of the steering column cover with the buttons facing downwards.

Note: There are markings on the cover to help locate the correct position.

When the Smart Key is positioned in this area, it will be recognised by the vehicle and the message **Smart Key Recognised** will be displayed in the message centre.

Holding the Smart Key in position and the brake pedal depressed, press the START/STOP button to start the engine.

Once the engine has been started, you no longer need to hold the Smart Key against the steering column cover.

Note: If the Smart Key is not recognised or the engine still fails to start, consult your Dealer/Authorised Repairer

SWITCHING OFF THE ENGINE



Never stop the engine when the vehicle is in motion.

Before stopping the engine, ensure that the vehicle is parked safely with the parking brake applied and the gear selector set to **P**.

Starting the engine

Press and release the engine START/STOP button to stop the engine. The audio, telephone and touch screen systems will revert to stand-by mode.

Pressing the START/STOP button again (without pressing the brake pedal), will activate the systems.

AUTOMATIC TRANSMISSION

Depending on the vehicle specification, there is a choice of gear selection control. The gear selector lever operates in a forward, back and sideways direction. The rotary gear selector rotates in either direction. When the engine is started, the rotary selector will elevate out of the centre console in readiness for gear selection.

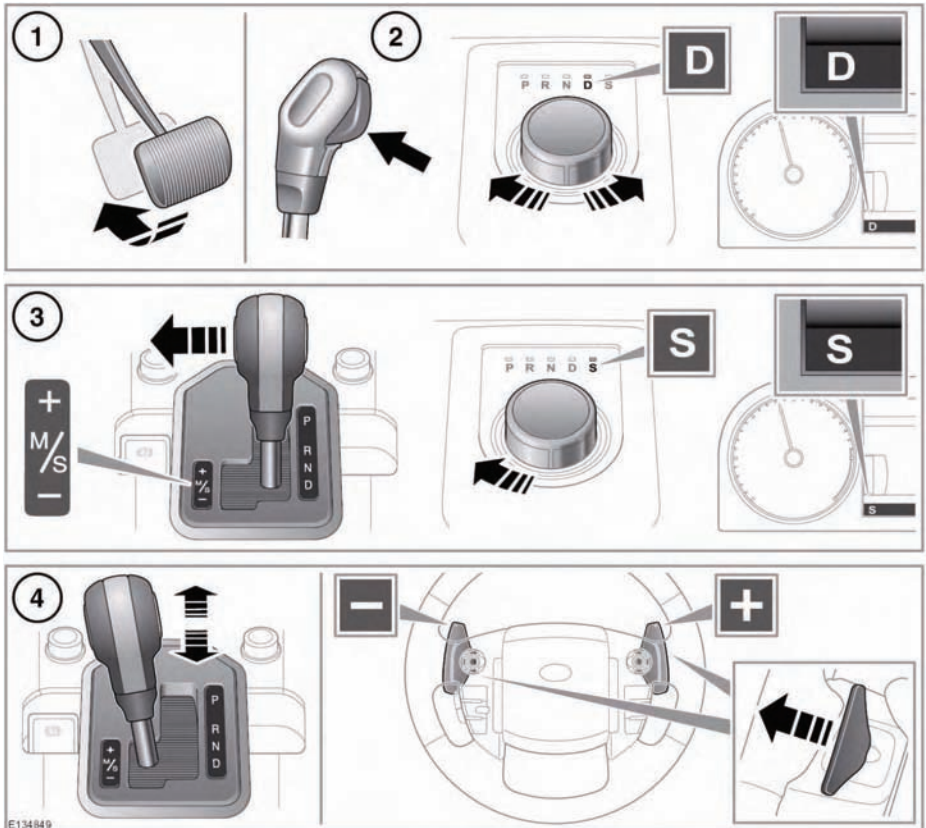

1. To select Drive (**D**) when the vehicle is stationary, first apply the foot brake.
2. With the selector lever, press in the release button and move the lever to **D**. If pressure is applied to the selector before the foot brake is applied, the selected gear may not be available. In this situation, remove pressure from the selector lever, ensure

that the foot brake is applied and select the required gear as described.

With the rotary selector, rotate to **D**. The paddle shifts can be used in this mode. Gear selection will revert to fully automatic if use of the paddles is not maintained.

D will appear in the instrument panel and the LED by the selector will illuminate.

3. To select sport mode with the selector lever, move the lever to the left.

With the rotary selector, press the selector down and rotate to **S**.

S will appear in the instrument panel and the LED by the selector will illuminate.

4. CommandShift™ can be used when **S** is selected.

With the selector lever, move the lever forward to move up a gear and back to move down gear. To return to the fully automatic sport mode, move the lever to **D** then back to **S**.

With the rotary selector, use the paddle shifts on the steering wheel for up and down shifts. Pull the left paddle (-) for downshifts and the right paddle (+) for upshifts. To return to the fully automatic sport mode, pull the right paddle for 2 seconds.

To return to drive mode move the selector back to the **D** position.

Should the transmission develop a fault, a warning message may be displayed in the message centre and only limited gears may become available. You should seek qualified assistance immediately.



Park (P) should be engaged and the parking brake applied when the vehicle is stationary.



Always select P and switch off the ignition before leaving the vehicle.



Never select **P** whilst the vehicle is in motion.



Never select Reverse (**R**) whilst the vehicle is in forward motion.



Never select a forward gear whilst the vehicle is in rearward motion.



Do not rev the engine, or allow it to run above normal idle speed, while selecting **D** or **R**, or whilst the vehicle is stationary with any gear selected.



Do not allow the vehicle to remain stationary for a sustained period, with a gear selected and the engine running. Always select **P** or **N** if the engine is to idle for a prolonged period.

Rotary selector

P should normally be selected before switching off the engine. If any other gear is selected at turn off, the selector will move to **P** before retracting into the centre console.

If the engine is switched off with **N** selected, the system will wait for 10 minutes before selecting **P**. This time delay allows the vehicle enough time to be conveyed through a car wash.

If the selector fails to rotate to **P** when the engine is switched off, when the engine is next switched on, **P** must be selected before the engine will start.

In the event of a vehicle breakdown, the transmission will automatically select **P**. This prevents the vehicle from being towed on all four wheels. Therefore, vehicle recovery should only be undertaken by suitably qualified personnel.

If the rotary selector is obstructed, remove the obstruction and then start the engine. The selector should elevate as normal. If the selector fails to elevate, it can be used in the lowered position, but be aware that it will not automatically select **P** when the engine is switched off. **P** should be selected manually. The fault should be rectified by a Dealer/ Authorised Repairer at the earliest opportunity.

COMMANDSHIFT™

If CommandShift™ is selected in high range, gears 1 or 2 may be used for moving off from stationary. In low range, gears 1, 2 or 3 may be used, which may prove useful in certain off-road driving conditions.

TRANSMISSION COMMANDSHIFT SELECTED will appear in the message centre when the transmission is in CommandShift mode.

Note: *In order to protect the engine, the transmission will automatically change up to prevent over-revving, or down if the engine is labouring.*

HILL DESCENT

With Hill Descent Control (HDC) selected in either automatic, Sport or CommandShift modes, a low gear will be selected and maintained to provide maximum engine braking. Should the gear lever be moved to **D** from the Sport/CommandShift position, the selected gear will be retained until the descent is completed. See **102, HDC OPERATION**.

TRANSFER GEARBOX



1. High range (Hi):

Hi should be used for all normal road driving and also for off-road driving across dry, level terrain.

2. Low range (Lo):

Lo should only be used in situations where low speed manoeuvring is necessary.

Also use **Lo** for more extreme off-road conditions. Do not attempt to use **Lo** for normal road driving.

STATIONARY RANGE CHANGING

With the vehicle stationary, select **N**.

Move the transfer gear switch towards the range required and release. The switch returns to the default position and range change status will be confirmed after several seconds.

RANGE CHANGE INDICATORS

In **Hi**, the **Hi** range switch indicator is illuminated.



In **Lo**, the green warning lamp in the instrument pack and the **Lo** range switch indicator are illuminated.

While a range change is in progress, the range indicator lamps will flash as follows:

Hi to Lo change:

- The **Lo** range warning lamp and indicator flash during the change and then illuminate constantly.
- The **Hi** range indicator extinguishes when the change is complete.
- The message **LOW RANGE SELECTED** is briefly displayed in the message centre.

Lo to Hi change:

- The **Hi** range indicator and the **Lo** range lamp and indicator flash during the change.
- The **Hi** range indicator illuminates constantly when the change is complete.
- The **Lo** range indicator extinguishes when the change is complete.
- The message **HIGH RANGE SELECTED** is briefly displayed in the message centre.

RANGE CHANGING ON THE MOVE

The recommended method of changing range is with the vehicle stationary. For experienced off-road drivers, a range change on-the-move can be accomplished, as detailed below.

AUTOMATIC TRANSMISSION HIGH TO LOW RANGE

1. With the vehicle slowing down, and travelling between 40 km/h (24 mph) and 3 km/h (2 mph), select **N**.
2. Press the rear of the transfer gear switch to select **Lo**.
3. Wait for the range change to be completed (this may take several seconds). Once complete, select the desired gear. A gear cannot be selected until the range change is complete.

CHANGING FROM LOW TO HIGH RANGE

With the vehicle travelling no faster than 60 km/h (38 mph), select **N** or neutral. Press the front of the transfer gear switch to the **Hi** position and release it.

Indication of the range change status is the same as for the stationary method.

Now select **D**.

STABILITY CONTROL WARNING LAMPS



The DSC warning lamp in the instrument pack illuminates briefly when the ignition is turned on.

If the warning lamp flashes rapidly during driving, the system is active.

A fault with the DSC system is indicated by the DSC warning lamp illuminating and an associated warning message. The vehicle can still be driven, but without DSC assistance. Seek qualified assistance as soon as possible.

SWITCHING DSC OFF



Safety may be reduced by inappropriately disabling DSC. In the majority of driving situations, and particularly on-road, it is recommended that you do not disable DSC.

In some driving conditions it may be appropriate to disable DSC to improve traction. These conditions include:

- Rocking the vehicle out of a hollow or deep rut.
- Pulling away in deep snow, or a loose surface.
- Driving through deep sand or mud.

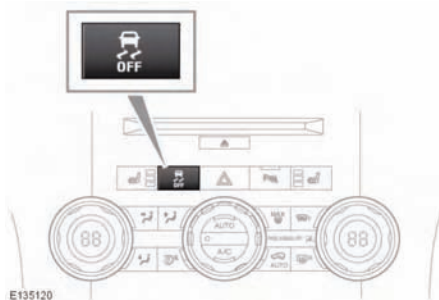

To disable DSC, press and briefly hold the DSC OFF switch on the fascia (the DSC off warning lamp will illuminate continuously).

Deactivating DSC also reduces the level of Traction control intervention and may lead to an increase in wheel spin.

SWITCHING DSC ON

DSC is re-enabled by one of the following:

- Press and briefly hold the DSC OFF switch.
- Start the engine.
- Select a new Terrain response special program.

AIR SUSPENSION SYSTEM



Ensure that the vehicle is clear of people and obstacles before lowering the suspension. The difference between Off-road height and Access height is 105 mm (4.1 in).

The air suspension system may be used to raise or lower the height of the vehicle, using the air suspension control switch.

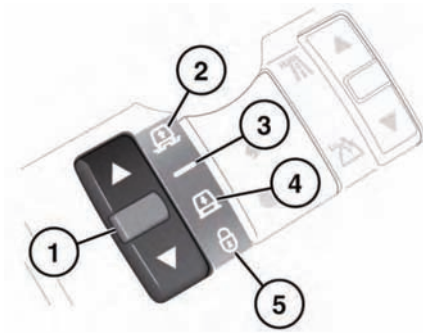

E134945

1. Raise/lower switch: The up and down arrows will illuminate when a height change is in progress.
2. Off-road height indicator: Off-road height is 55 mm (2.2 in) higher than normal height.
3. Normal height indicator.
4. Access height indicator: Access height is 50 mm (2.0 in) lower than normal height.
5. System lock indicator.

Note: The system may raise or lower the vehicle automatically (e.g. if a Terrain response program requires it, or if the vehicle is travelling at high speed).

Changes to the height of the vehicle must be made when all doors are closed. Except for remote operation (see 87, **REMOTE OPERATION**), the engine must also be running. If a door is opened during a height change, the height change will be suspended. If the door is closed within 90 seconds, the height change will then complete. If the doors are not closed in time, the desired height should be reselected once the doors are closed. Driving off will return the vehicle to normal height.

Note: If the air suspension is used many times in succession, speed of operation may slow.

SELECTING OFF-ROAD HEIGHT

Off-road height can be selected by pressing up on the raise/lower switch (1) at any speed up to 40 km/h (24 mph). If selected, and the speed exceeds 50 km/h (30 mph), a warning will appear in the message centre and the system will return to normal height.

SELECTING ACCESS HEIGHT

To select access height from normal height, press down on the raise/lower switch. To select access height from Off-road height, press down on the switch once, and then a second time while lowering is in progress. **ACCESS HEIGHT SELECTED** will be displayed in the message centre.

If the vehicle speed is greater than 20 km/h (12 mph), the system will wait for the speed to decrease. If it does not fall below this speed within 1 minute, the height change will be cancelled.

Once the speed falls below 20 km/h (12 mph) the vehicle will be partly lowered. When the speed falls below 8 km/h (5 mph) within 1 minute, full access height will be reached.

Note: Access height may be selected up to 40 seconds after the ignition is switched off, provided the driver's door has not been opened.

When vehicle speed rises above 10 km/h (6 mph), the vehicle will return to the height access height was selected from.

CRAWL MODE (LOCKED ACCESS HEIGHT)

When the vehicle is at Normal height and travelling less than 35 km/h (22mph), or at Access height, press down on the raise/lower switch for longer than 3 seconds to lock the vehicle at access height. The system lock indicator (5) will illuminate and **SUSPENSION LOCKED AT ACCESS HEIGHT** will be displayed in the message centre.

The vehicle may then be driven slowly at access height, to assist with manoeuvring in confined areas (e.g. multi-storey car parks).

To cancel crawl mode, press up on the raise/lower switch for longer than 1 second. The system lock indicator will extinguish and if the vehicle is travelling faster than 10 km/h (6 mph) it will return to normal height.

Crawl mode will be cancelled automatically if the vehicle speed exceeds 40 km/h (24 mph).

EXTENDED OFF-ROAD HEIGHT

If grounded in severe off-road conditions, the system may automatically enter Extended mode. The off-road height indicator flashes and a message will be displayed in the message centre. In extended mode, the suspension will raise above off-road height to assist in clearing the obstacle.

Once extended mode height has been achieved, the driver may request additional lifting if required. This is achieved by pressing and holding the raise switch for longer than 3 seconds while pressing the brake pedal.

To cancel extended mode, press the lower switch (1). Extended mode will automatically be cancelled if the vehicle speed remains greater than 5 km/h (3 mph) for 30 seconds.

Note: Extended mode cannot be selected manually.

REMOTE OPERATION



The Smart Key can be operated from inside or outside the vehicle. It is therefore important that it is kept out of the reach of children at all times.



When operating the Smart Key from inside the vehicle, make sure that an adult checks for obstructions under the vehicle and supervises the raising or lowering process.



Care should be taken with all height changes, when a trailer is attached to the vehicle.

The buttons on the Smart Key may be used to operate the air suspension system, allowing the vehicle to be raised or lowered remotely. This may be useful in attaching a trailer or loading the vehicle.

To change the suspension height using the Smart Key, the vehicle must be stationary, all the doors closed and the hazard warning lamps switched on.

Air suspension

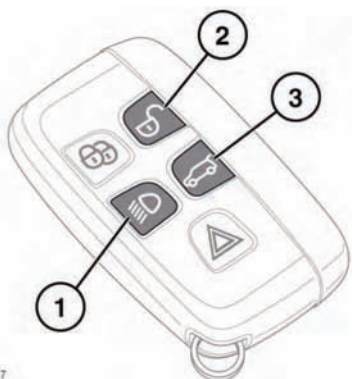

E134947

To raise the vehicle press and hold button (1), then press and hold button (2).

To lower the vehicle press and hold button (1), then press and hold button (3)

If the starting height is above or below normal height, movement will cease when normal height is reached. Release the Smart Key buttons and press again to continue.

IMPORTANT INFORMATION



Do not rest your foot on the brake pedal whilst the vehicle is in motion.



Never allow the vehicle to coast (freewheel) with the engine turned off. The engine must be running to provide full braking assistance. The brakes will still function with the engine off, but far more pressure will be required to operate them.



If the red brake warning lamp illuminates, safely bring the vehicle to a stop, as quickly as possible and seek qualified assistance.



Never place non-approved floor matting or any other obstructions under the brake pedal. This restricts pedal travel and braking efficiency.

Driving through heavy rain or water can have an adverse effect on braking efficiency. Under such circumstances, it is recommended that you lightly apply the brakes intermittently, to dry the brakes.

BRAKE WARNING LAMPS



The ABS warning lamp illuminates briefly when the ignition is turned on.

If this amber warning lamp illuminates when driving (accompanied by an associated warning message), drive with extra caution, avoid heavy braking where possible, and seek qualified assistance as soon as possible.

EMERGENCY BRAKE ASSIST (EBA)

If the driver rapidly applies the brakes, EBA automatically boosts the braking force to its maximum, in order to bring the vehicle to a halt as quickly as possible. If the driver applies the brakes slowly, but conditions mean that ABS operates on the front wheels, EBA will increase the braking force in order to apply ABS control to the rear wheels.

EBA stops operating as soon as the brake pedal is released.



The amber brake warning lamp illuminates briefly when the ignition is turned on.

A fault with the EBA system is indicated by the amber brake warning lamp illuminating and an associated warning message. Gently and safely stop the vehicle and seek qualified assistance.

ELECTRONIC BRAKE FORCE DISTRIBUTION (EBD)

EBD controls the balance of braking forces supplied to the front and rear wheels, in order to maintain maximum braking efficiency.

If the vehicle has a light load (only the driver in the vehicle for example), EBD will reduce the braking force applied to the rear wheels. If the vehicle is heavily laden, EBD will allow greater braking force to the rear wheels.



The red brake warning lamp illuminates briefly when the ignition is turned on.

A fault with the EBD system is indicated by the red brake warning lamp illuminating and an associated warning message. Gently and safely stop the vehicle and seek qualified assistance.

ELECTRIC PARKING BRAKE (EPB)

- ❗ The parking brake operates on the rear wheels. Therefore, secure parking of the vehicle is dependent on being on a hard and stable surface.
- ❗ Do not rely on the parking brake to operate effectively, if the rear wheels have been immersed in mud or water.

Note: If the vehicle is used in severe off-road conditions (e.g. wading, deep mud, etc.), additional maintenance and adjustment of the parking brake will be required. Consult your Land Rover Dealer/Authorised Repairer.

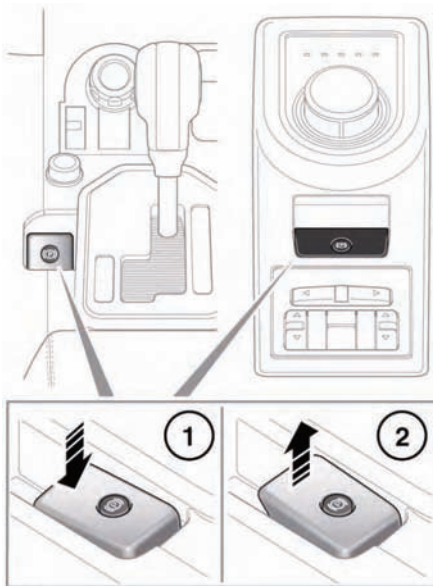

The switch which operates the parking brake is mounted on the centre console to the rear of the gear selector.

To disengage the parking brake (1): With the ignition system on or with the engine running, apply the foot brake and press the parking brake switch down.

If the parking brake is applied while the vehicle is stationary and **D** or **R** is selected, applying the throttle will automatically release the parking brake.

The parking brake is also automatically released when the gear selector is moved from the **P** position.

If the parking brake is inadvertently applied when the vehicle is moving at above 3 km/h (1.8 mph), **Caution! Park Brake Applied** is displayed in the message centre, the warning indicator in the instrument panel will illuminate and a warning chime will sound.

If the parking brake is applied whilst the vehicle is moving, releasing the switch will disengage the parking brake. The parking brake cannot be applied when the vehicle is moving, if the accelerator pedal is pressed.

Note: If the vehicle is in motion, the parking brake should only be used as an emergency brake.

- ❗ Always apply the parking brake when the vehicle is parked.

To engage the parking brake (2): Pull the parking brake switch upwards and release. The switch will return to the neutral position.

(P) The Parking brake warning lamp on the instrument panel will illuminate.

The Drive Away Release feature allows the parking brake to release automatically as the vehicle is driven away.

The warning lamp in the instrument panel will remain on for a short time, if the parking brake is applied when the ignition system is reverted to the convenience mode.

If a fault in the system is detected, **Park Brake Fault** or **Cannot Apply Park Brake** will be displayed in the message centre. Seek qualified assistance as soon as possible.

If the battery has been discharged or disconnected, **Apply Foot And Park Brake** will be displayed in the message centre when the ignition is next switched on. Depress the foot brake and pull the parking brake switch up to apply the parking brake. This is required to reset the parking brake system. The parking brake will now function correctly.

Tyre pressure monitoring system

TYRE PRESSURE MONITORING SYSTEM (TPMS)



The TPM system provides a low pressure warning and does not re-inflate your tyres. Tyre pressures should be checked regularly using an accurate pressure gauge when cold.



The TPM system can NOT register damage to a tyre. Regularly check the condition of your tyres, especially if the vehicle is driven off-road



When inflating tyres, care should be taken to avoid bending or damaging the TPM system valves. Always ensure correct alignment of the inflation head to the valve stem.

Note: Different types of tyre may affect the performance of the TPM system. Always replace tyres in accordance with recommendations.

The tyre pressure monitoring system constantly monitors the tyre pressure in each wheel, including the full size spare. Temporary use spare tyres (when fitted) are not monitored.

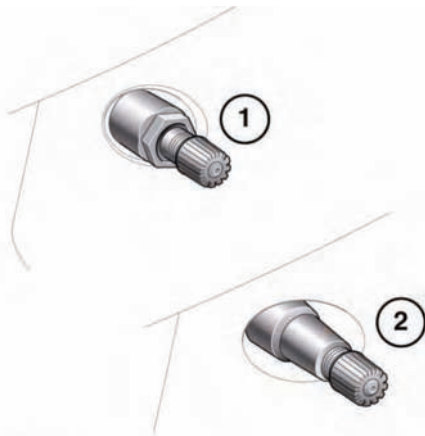

E132513

Wheels fitted with a TPM system can be identified by the appearance of the external metal lock nut and valve (1). All Land Rover non-TPM system wheels have a rubber valve fitted (2).

Tyre pressures should be checked regularly when cold, and adjusted as necessary. The presence of the TPM system does not remove the need to do this to ensure vehicle safety.



The tyre pressure warning lamp illuminates when one or more of your tyres is significantly under-inflated. You should stop and check your tyres as soon as possible, and inflate them to the recommended pressure for the vehicle loading condition.

The TPM system also monitors the full size spare tyre pressure. If the pressure for the spare tyre is incorrect, the message **CHECK SPARE TYRE PRESSURE** is displayed, accompanied by illumination of the warning lamp.

VEHICLE LOADING

It is possible to select different tyre pressure monitoring levels that correspond to the pressures on the tyre pressure label for a lightly laden or heavily laden vehicle.

The different tyre pressure monitoring levels can be set via the Vehicle setup menu (see **52, INTERACTIVE CONTROLS**).

FULL SIZE SPARE WHEEL AND TYRE CHANGE

The system will automatically recognise any changes in wheel positions. The vehicle must be stationary for 15 minutes during the wheel and tyre change (see **220, REMOVING THE SPARE WHEEL**), to ensure that the system can detect the change. After driving above 25 km/h (18 mph), any deflation warning should clear within a few minutes.

If the temporary spare wheel is fitted, the system will automatically recognise the change in wheel positions. After approximately 10 minutes of driving above 25 km/h (18 mph), the message **FRONT (REAR) RIGHT(LEFT) TYRE PRESSURE NOT MONITORED** will be displayed, accompanied by illumination of the warning lamp.

The warning lamp will first flash and then illuminate continuously. Extended use of the temporary spare wheel will trigger the message **TYRE PRESSURE MONITORING SYSTEM FAULT**.

This TPM system display sequence will be activated at every ignition cycle, until the temporary spare wheel is replaced by a full-size road wheel.

Note: *If in use, always replace the temporary spare wheel before having a TPM system fault investigated.*

USING THE PARKING AID

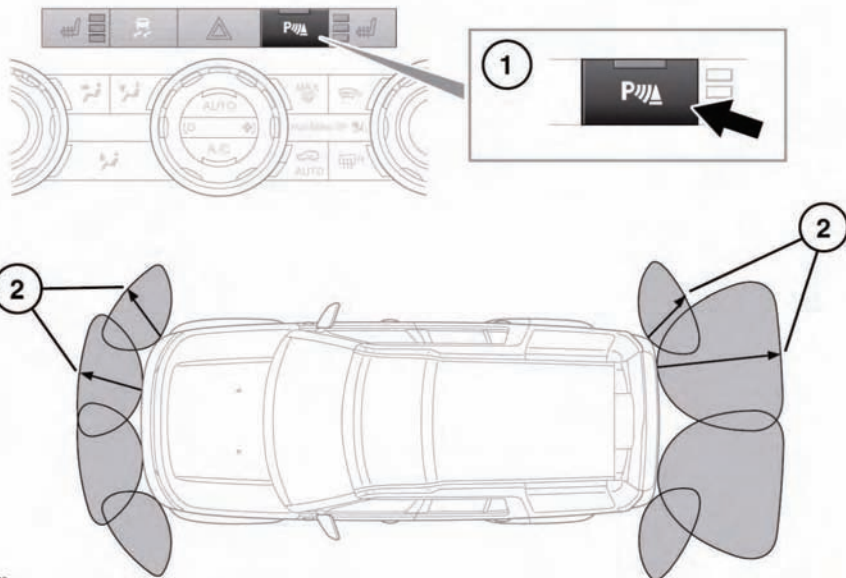

E134852



Parking aids may not detect moving objects such as children and animals, until they are dangerously close. Always use extreme caution when manoeuvring.



PDC sensors may not detect some obstructions (e.g. narrow posts, small objects close to the ground and some objects with dark non-reflective surfaces).

1. When reverse gear is selected, the front and rear parking sensors are activated automatically, and the switch indicator will illuminate.

To manually activate the front sensors press the PDC button, a short confirmation tone will be heard, and the switch indicator will illuminate.

To turn off the system when active, press the button. The switch indicator will extinguish.

2. The range of the parking aid sensors varies between the front, rear and corners of the vehicle. The front sensors and rear corner sensors have an approximate range of 600 mm (24 ins). The centre rear sensors have an approximate range of 1500 mm (60 ins).

The front sensors will remain active as long as the vehicle's speed does not exceed 16 km/h (10 mph).

Selecting **N** from **R** will keep front and rear sensors active.

When objects are detected, the parking aid emits a warning tone which increases in frequency as the vehicle gets closer to the object and then becomes constant when the obstacle is within 300 mm (12 ins).

Note: The front parking aid provides an audible proximity warning when driving forwards and when reversing.

CLEANING THE SENSORS

⚠ When washing the vehicle do not aim high pressure water jets directly at the sensors. Do not use abrasive materials or hard/sharp objects to clean the sensors. Only use approved vehicle shampoo.

The sensors should be kept clean to maintain accuracy and performance.

PARKING AID SYSTEM FAULT

If a system fault is detected, a long high-pitched tone will sound, and the switch indicator will flash. Contact your Dealer/ Authorised Repairer as soon as possible.

REAR VIEW CAMERA



It remains the driver's responsibility to detect obstacles and estimate the vehicle's distance from them when reversing.

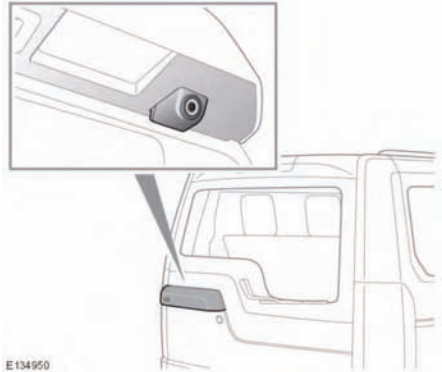

When reverse gear is selected, the touch screen automatically displays a wide angle, colour image from the rear of your vehicle.

The rear view camera system provides a rear view image to assist in reversing the vehicle. Overlaid on the image are reversing guidelines.

Note: A return icon is displayed in the bottom right hand corner of the touch screen. Touch this to revert to the previously viewed screen.

Rear view camera display on the touch screen will discontinue when either of the following apply:

- Drive is selected for longer than 15 seconds.
- Drive is selected and/or vehicle speed is greater than 18 km/h (11 mph).

USING CRUISE CONTROL

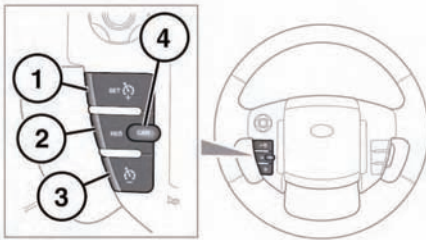

E134853

1. Set target speed, or increase speed.
2. Resume set speed.
3. Decrease set speed.
4. Cancels cruise control operation without erasing memorised speed.

Note: Cruise control is not available when using Hill Descent Control or when a Terrain Response special program has been selected.

Note: Do not use cruise control when driving off-road.

Note: Do not use cruise control with **SPORT** mode selected.

SETTING VEHICLE SPEED



When setting the cruise control to the speed limit, it is important to remember that it is possible for the vehicle speed to increase when travelling downhill. This may result in the vehicle speed exceeding the speed limit.

Note: Cruise control can only be engaged at speeds in excess of 30 km/h (18 mph).

Accelerate until the desired speed is reached, then press the **+** switch (1) until the warning lamp illuminates. This sets the vehicle speed into the system's memory. Cruise control will now maintain that speed.



The cruise control warning lamp will illuminate to confirm cruise control is operational. Speed can be increased using the accelerator pedal as normal. As soon as the accelerator pedal is released, the vehicle speed will return to the set cruising speed.

Note: If the accelerator pedal is pressed for more than 5 minutes, cruise control will be cancelled.

CHANGING THE CRUISE SPEED

Decreasing speed

To decrease the cruising speed, press and hold the **-** switch (3). Release the switch when the desired speed is reached, the new speed will be set and maintained.

The set speed can be decreased in steps of 2 km/h (1 mph) by briefly pressing the **-** switch.

Increasing speed

Press and hold the **SET+** switch (1) to increase cruising speed. Release the switch when the desired speed is reached, the new speed will be set and maintained.

Cruising speed can also be increased using the accelerator. When the desired speed is reached, press the **SET+** switch to set and maintain the new speed, and release the accelerator.

The set speed can be increased in steps of 2 km/h (1 mph) by briefly pressing the **SET+** switch.

SURROUND CAMERA SYSTEM

The camera home page is accessed from the **Home menu** screen. If Cameras has not been set as a short cut, touch **Extra Features** to display the list.

With the engine running and Park or Neutral selected, the surround camera system uses 5 discretely placed cameras to assist in manoeuvring the vehicle.



E136049

1. **Enlarge:** To enlarge a camera view, touch the image then touch the **Enlarge** soft key. Any 2 images can be selected and enlarged to view side-by-side on the screen.

When viewing the two images, one of them can be selected to view as a full screen image. It can then be zoomed into and panned around using the magnifier and arrow icons.

2. **Proximity View:** Touch to select a combination of 3 images from the front and passenger side cameras.

Automatic Proximity View: - Japan only:

When Drive or Reverse is selected, the forward or rear view will be displayed. Once the vehicle speed 18 km/h (11 mph) or the return icon is pressed, the camera screen will disappear.

Note: *Proximity view can be accessed at any time by touching Proximity View on the Camera home page.*

3. **Special Views:** A selection of pre-set views can be displayed by selecting **Special Views**. They are provided to assist with difficult manoeuvres and are:
 - **Kerb view:** Shows views from the 2 front cameras.
 - **Junction view:** Shows views from the 2 side cameras.
 - **Trailer view:** Shows the rear camera view.
4. **Camera Setting - Japan only:** Touch to access the camera options page. To deactivate the Semi-auto camera functionality select **Off**. The Proximity view is now only accessible by manual activation using the **Proximity View** soft key.
5. **Tow Assist:** Touch to display trailer guidance set-up screen.

PROXIMITY VIEW - MANUAL OPERATION

Selecting **Proximity View** will display a combination of three images from the front and passenger side cameras.

CAMERA CLEANLINESS

If the colour of the camera position arrow in the display changes from blue to red, the system has detected that the camera is dirty. Clean the camera in accordance with the guidelines given on page, **190, CLEANING THE EXTERIOR**.

TRAILER GUIDANCE

Note: Trailer guidance requires a connected trailer to be fitted with a tracking target sticker, which **must** be attached according to specific instructions. Ask your Dealer/Authorised Repairer for details.



E134952

Note: This feature may not operate with all trailer designs.

Trailer guidance aids trailer reversing, by displaying information on the touch screen.

Trailer guidance becomes active when a trailer is attached to the vehicle and the trailer electrical plug is attached to the vehicle socket. The screen will display a choice for connection. Select **YES** to move to the setup screen. Select **NO** to return to the previous screen.

Note: If the connection is not detected, setup can be manually prompted by touching the Tow Assist soft key on the Camera menu.

TRAILER SETUP

On first use, the setup screens take the user through a series of configuration options for the connected trailer. Information such as trailer length, number of axles and camera preference is required to finalise setup. Once complete, the details are stored for future use.

CAMERA SYSTEM OPERATION

When a new or existing trailer configuration is selected, Trailer guidance will automatically display on the touch screen when reverse gear is selected. Coloured lines are displayed to indicate the predicted path of both trailer and vehicle.

BEFORE DRIVING OFF-ROAD

Before venturing off-road, it is absolutely essential that inexperienced drivers become fully familiar with the vehicle's controls. In particular, CommandShift™, Hill Descent Control (HDC) and the Terrain response system.

TERRAIN RESPONSE OPERATION

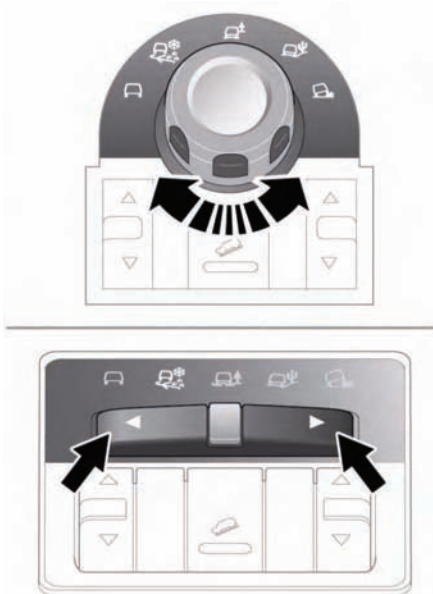

E136700

Depending on the vehicle specification, there is a choice of Terrain Response control.

When the vehicle is fitted with a gear selector lever, Terrain Response selection is via a rotary control. There are five Terrain Response programs marked around the control.

When the vehicle is fitted with a rotary drive selector, Terrain Response selection is via a rocker switch. Use the switch to move forward or back through the five program selections.

Information relating to the suitability of each terrain response program on different types of surface, is given on the touch screen, via the **Extra features** soft key. Touch the terrain response icon, then the information icon. The displayed text is relevant to the currently selected terrain response program.

GENERAL PROGRAM (SPECIAL PROGRAMS OFF)



This program is compatible with all on and off-road conditions. If not already active, it should be selected before driving on surfaces which are similar to a hard road surface. Dry cobbles, tarmac, dry wooden planks, etc., all fall into this category.

This program should be selected once the need for a special program has passed. Once the special program has been deselected, all of the vehicle systems will return to their normal settings except HDC. HDC will remain active if it was selected manually.

GRASS/GRAVEL/SNOW



This program should be used where a firm surface is covered with loose or slippery material.

Note: For deep gravel it is recommended that the Sand program is selected.

Note: If the vehicle is unable to gain traction in deep snow, switching DSC off may help. DSC should be switched on again, as soon as the difficulty is overcome.

Terrain response

MUD-RUTS



This program should be used for crossing terrain that is muddy, rutted, soft or uneven.

Low range is recommended for this program and if not selected, the message centre will prompt you.

If the Mud-Ruts program and Low range are selected together, the vehicle ride height will be raised automatically.

SAND



This program should be used for terrain which is predominantly soft dry sand or deep gravel.

Note: *If the vehicle is unable to gain traction in extremely soft, dry sand, switching DSC off may help. DSC should be switched on again as soon as the difficulty is overcome.*

If the sand to be crossed is damp/wet, and sufficiently deep to cause the wheels to sink into the surface, the Mud-Ruts program should be used.

ROCK CRAWL



This program should be used for terrain which is predominantly rocky, including for crossing river beds with submerged rocks.

This program provides good low-speed control.

Rock crawl can only be selected in Low range. If the selection is made while in High range, the message centre will prompt you to select Low range.

DRIVER OVERRIDE OPTIONS

Hill Descent Control (HDC) is automatically engaged for some terrain response programs. If required, HDC can be deselected or engaged independently of terrain response.

The HDC status will be displayed on the message centre whether it is engaged, or disengaged, by the system or by the driver.

Although Dynamic Stability Control is automatically engaged when a special program is selected, it can be turned off if required

SYSTEM DIFFICULTIES



Use of an incorrect program will impair the vehicle's response to the terrain and can reduce the life of the suspension and drive systems.

If the system becomes partially inoperable for any reason, it may not be possible to select special programs.

If a participating vehicle system becomes temporarily inoperable, the General program will be automatically selected. Once the system returns to normal operation, the previously active program will be re-activated unless the ignition has been turned off in the mean time.

If you try to select an inappropriate special program (e.g. selecting Rock crawl while in High range), the relevant indicator will flash amber and the message centre will provide further information. If the appropriate action is not taken within 60 seconds, the warnings will cease and the message centre will show the active program.

If the system becomes completely inoperable, all of the special program indicators will be switched off and a relevant message will be displayed in the message centre.

Hill descent control (HDC)

SELECTING HDC

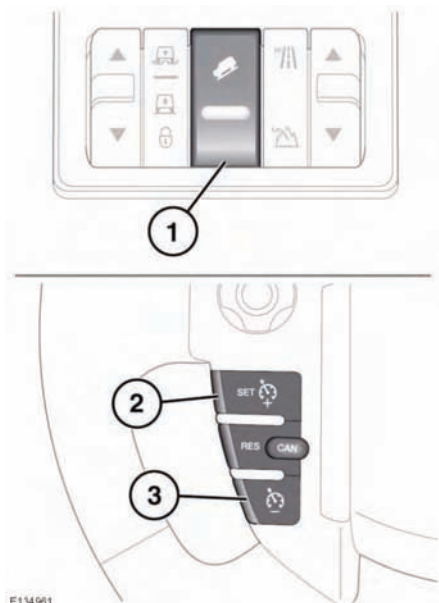

1. Press to switch HDC on and off.
2. Press to increase the set speed.
3. Press to decrease the set speed.

HDC can be selected at speeds below 80 km/h (50 mph).

Manual transmission: HDC can be used in first or reverse gears when in Hi range and in all gears when in Lo range.

Automatic transmission: HDC can be used in **D**, **R** or CommandShift **1** when in Hi range and in **D**, **R** and all CommandShift gears when in Lo range. When in **D**, the vehicle will select the most appropriate gear.

Note: *HDC is automatically selected by some of the Terrain response special programs.*

To select HDC, press and release the HDC on/off switch (1).



If the HDC lamp flashes, HDC has been selected but is not operating. This is caused by the system's operating conditions not being met (e.g. vehicle speed too high).

If HDC is deselected while operating, the lamp will flash and the system will fade out, allowing the vehicle speed to gradually increase.

If the vehicle speed exceeds 80 km/h (50 mph) HDC will disengage, and the HDC lamp will extinguish.

Note: *HDC is automatically deselected if the ignition is switched off for more than 6 hours.*

HDC OPERATION

With HDC engaged, the speed of descent can be altered using the cruise control steering wheel switches, as follows:

- To increase speed press and hold the + switch (2) until the desired speed is achieved.
- To decrease speed press and hold the - switch (3) until the desired speed is achieved.

When the switch is released, the selected speed will be maintained.

To increase or decrease speed gradually, tap the + or - switch as required. Each tap of the switch will increase/decrease the speed in increments/decrements of 0.5 km/h (0.3 mph).

The accelerator pedal can also be used to increase speed, up to the threshold in each gear.

Note: *Each gear has a pre-determined minimum speed.*

Descent speed will only increase on a slope steep enough to provide additional momentum. Therefore, use of the + switch on a gentle slope may not increase the speed.

When using HDC in manual transmission vehicles, depressing the clutch pedal will prevent HDC from controlling the speed of descent.

If the brake pedal is depressed, HDC will be overridden and the brakes will operate as normal. When the brake pedal is released, HDC will resume control of the descent.

If HDC is switched off during a descent via the brake pedal, HDC assistance will fade out gradually. This is to prevent loss of control if HDC is switched off in error. HDC will resume control when switched back on if assistance is still required, but at the speed the vehicle is travelling when the brake pedal is released.

GRADIENT RELEASE CONTROL (GRC)

With HDC activated, if the vehicle is stopped on a slope using the foot brake, GRC will become active (except in Terrain response Sand program). During a hill ascent when the foot brake is released GRC will automatically delay and graduate the brake release, to allow the vehicle to move smoothly away. When descending a hill, a similar brake hold and gradual release is employed to provide a smooth transition into HDC control.

GRC operates in forward and reverse gears and requires no driver intervention.

ASCENDING STEEP SLOPES

When ascending steep slopes with HDC selected, the vehicle will allow full control to the driver in the normal manner. If HDC is switched off, the maximum vehicle speed will be limited to allow more accurate control of the ascent.

WARNING MESSAGES



Do not attempt a steep descent if HDC is inoperative or warning messages are displayed.

BRAKE TEMPERATURE

In extreme circumstances, the HDC system may cause brake temperatures to exceed their pre-set limits. If this occurs the warning **HDC TEMPORARILY UNAVAILABLE** will be displayed in the message centre. HDC will then fade out and become temporarily inactive.

Once the brakes have reached an acceptable temperature, the message will disappear (or the warning lamp will extinguish) and HDC will, if required, resume operation.

SYSTEM FAULT

If a fault is detected in the HDC system, **HDC FAULT SYSTEM NOT AVAILABLE** will appear in the message centre.

If the fault is detected whilst the system is operating, HDC assistance will fade out.

If a fault is detected, contact your Land Rover Dealer/Authorised Repairer as soon as possible.

Standard audio system

STANDARD AUDIO SYSTEM CONTROLS

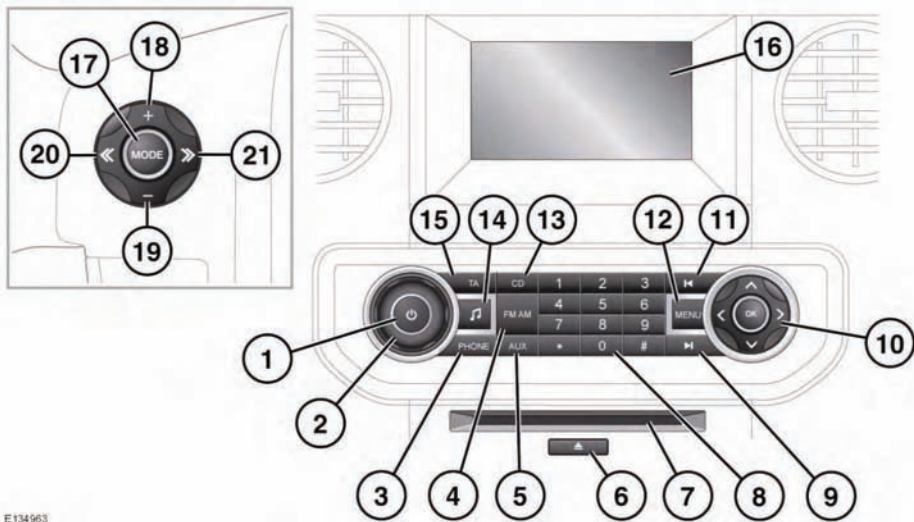

E134963



Sustained exposure to high sound levels can damage your hearing.

Note: The maximum volume level will be restricted if the audio unit is used with the engine switched off.

1. Audio system on/off: Press to switch on and off.

Note: The audio system will switch off automatically after 10 minutes if the ignition is turned off.

2. Volume control: Rotate to adjust volume.
Note: The maximum volume level will be restricted if the audio system is used with the engine switched off.
3. **PHONE:** Press to select telephone menu. See **112, TELEPHONE SYSTEM.**
4. **RADIO** waveband select (FM, FMAST, AM, AMAST, plus if fitted DAB1, DAB2).
5. **AUX** input select.
6. CD eject button.
7. CD loading slot.

8. Keypad.

9. Seek up:

Short press to select the next station upward in frequency or, to select the next track on chosen audio source.

Long press to enter radio manual seek mode or, to scan forward through a CD track.

In radio manual seek mode further short presses will change the frequency in single increments.

10. **OK** and menu navigation control.

Use the menu navigation control to move any menu cursor/highlight. When the required option is highlighted, press the **OK** button to select.

11. Seek down:

Short press to select the previous radio station downwards in frequency or, to select the previous track on chosen audio source.

Long press to enter radio manual seek mode or, to scan backwards through a CD track.

In radio manual seek mode further short presses will change the frequency in single increments.

12. **MENU**: Press to select audio system menu, with the following options:
 - Audio settings.
 - Clock settings.
 - Language.
13. **CD**: Press to select CD mode.
14. **Tone**: Press to select the tone menu.
15. **TA**: Traffic information.
16. Audio system information display.
17. **MODE**: Press repeatedly to scroll through all audio modes.
18. Steering wheel volume up.
19. Steering wheel volume down.
20. Seek down:

Short press to select the previous radio preset or the previous track on chosen audio source.

Long press to scan backwards through a track.
21. Seek up:

Short press to select the next radio preset or the next track on chosen audio source.

Long press to scan forwards through a track.

ADAPTIVE VOLUME CONTROL (AVC)

The AVC feature adjusts the volume level to compensate for the changes in road noise as the vehicle speed increases or decreases.

Note: *The AVC setting represents the volume increase and not the volume level.*

If the AVC level is set to **zero**, there will be no volume increase. With a low level setting, the volume increase at speed will be minimal. If a high level setting is used, there will be a noticeable increase of volume at greater speed.

To set the AVC level:

1. Press the **MENU** button, then using the menu navigation control (**10**) press up or down to select **AUDIO settings** to access the volume settings menu. Select **Adaptive Vol.**
2. Use the left and right buttons on the menu navigation control (**10**) to adjust the AVC setting.
3. Press **OK** to confirm the selection.

ADJUSTMENT

Press the Tone button (**14**) to display the Tone menu. The settings for bass, treble, balance and fade can be adjusted using the navigation buttons. Press **OK** to store the settings and return to the previous screen.

Note: *If no adjustment is made within 10 seconds, the display will revert to the previously displayed screen.*

AUTO STORING RADIO STATIONS

AutoStore can be used to store the stations with the strongest signals available, either from the AM or the FM waveband.

Using Autostore:

1. Press **RADIO** button (**4**) to select the desired waveband.
2. Find a station. If necessary, use the seek buttons (**9** and **11**).
3. Press and hold the **RADIO** button until the display confirms that Autostore is in progress.

Standard audio system

The system will search for stations with the strongest signals on the selected waveband. While the search is in progress, volume is muted.

When the search is complete, the previous volume level will be restored. The radio will switch to the FM-AST or AM-AST waveband where the strongest signal stations have been stored on the Autostore presets.

Note: *AutoStore will store up to a maximum of the 10 strongest signals available and overwrite the previously stored stations.*

Note: *The AutoStore waveband can also be used to store stations manually, in the same way as other wavebands.*

RADIO STATION PRESETS

This feature allows favourite stations to be stored so that they can be recalled later.

1. With the **RADIO** button (4), select a waveband.
2. Tune to the required station. The station will begin to play.
3. Press and hold one of the keypad buttons.
4. The station will be stored under the selected number. Volume will mute momentarily as confirmation.
5. Release the keypad button.

This can be repeated on each waveband and for each preset button.

When in radio mode, stored stations can also be selected by pressing the menu navigation control (10). Scroll to the desired preset station and press **OK**.

Note: *When driving to another area of the country, FM stations that broadcast on alternative frequencies and are stored on preset buttons, may be updated with the correct frequency for that area.*

RADIO DATA SYSTEM (RDS)

Your audio unit is equipped with RDS, which enables the audio unit to receive additional information with the normal radio signals.

On the FM waveband, RDS enables the audio to receive traffic and news information broadcasts. RDS also allows the audio to automatically re-tune to stations that are linked to the same network, if that network allows this.

Note: *Not all FM radio stations broadcast RDS. If a non-RDS station is selected, RDS features will not be available.*

REGIONALISATION (REG)

As you drive into different radio reception areas, RDS automatically re-tunes the radio to the strongest signal. When REG is on, the tuner is locked to the current local radio station. With REG switched off, the tuner is allowed to switch to a stronger Enhanced Other Network (EON) when the current EON linked radio station signal becomes weak.

To enable/disable regionalisation:

1. Press the **MENU** button (12).
2. Select **Audio Settings** on the screen menu.
3. Select **Regional mode**.
4. Press **OK** to enable or disable REG.

ALTERNATIVE FREQUENCY (AF)

Some radio stations broadcast on different frequencies in different parts of the country. If the selected station signal weakens, the radio will automatically re-tune to a stronger Alternative Frequency (AF), if one is available. This feature is particularly useful on long journeys, where the vehicle travels through different transmitter areas serving the same radio station.

To enable/disable AF:

1. Press the MENU button (12).
2. Select **Audio Settings** on the screen menu.
3. Select **ALTERNAT. FREQ.** Turn AF on or off.
4. Press **OK**.

SELECTING TRAFFIC INFORMATION

Normal reception can be interrupted to broadcast traffic information from stations on the FM waveband or Radio Data System (RDS) and Enhanced Other Network (EON) links.

When a radio station capable of providing traffic information is selected, the **TP** indicator appears on the top line of the display.

Briefly press the **TA** button (15) to select the Traffic Announcement (TA) function. The **TA** indicator appears on the top line of the display.

As soon as a traffic announcement is received, the current entertainment source (CD, USB, iPod or Radio) is interrupted and the message **Traffic** appears in the main display area, along with the name of the station providing the information.

If a non-traffic station is selected or recalled using a preset button, the audio unit will remain on that station unless **TA** is turned off, then on again.

TRAFFIC ANNOUNCEMENT VOLUME

Traffic announcements interrupt normal broadcasts at a preset minimum level that is usually louder than normal listening volumes. To adjust the preset volume, use the volume control to make the necessary adjustment during an incoming TA broadcast. The display will show the level selected.

All subsequent traffic announcements will be at the set volume.

CANCELLING AN ANNOUNCEMENT

To cancel an announcement, briefly press the **TA** button or alternatively the **MODE** button (17) on the steering wheel during the announcement. This will not turn off TA.

Note: If TA is pressed at any other time, all announcements will be switched off.

SWITCHING OFF TRAFFIC INFORMATION

Briefly press the **TA** button (the **TA** indicator will disappear from the top line of the display). This action will prevent traffic information broadcasts from being received, until the feature is reselected.

SELECTING NEWS INFORMATION

Normal reception can be interrupted to broadcast news bulletins from stations on the FM waveband or Radio Data System (RDS) and Enhanced Other Network (EON) linked stations, in the same way that traffic information is provided.

To set the NEWS feature:

1. Press the MENU button (12).
2. Select **Audio Settings** on the screen menu.
3. Select **News**.
4. Press **OK** to enable or disable the News feature.

To cancel an announcement, see 107, **CANCELLING AN ANNOUNCEMENT**.

Note: Both traffic and news information can be selected at the same time. However, the radio will always give priority to traffic information.

DIGITAL (DAB) RADIO

If your vehicle is equipped for digital radio, press the RADIO button (4) to select either of two groups DAB1 or DAB2. These two groups permit the storing of a total of 20 preset stations or 'services' (ten in each group) using the buttons 0-9 on the keypad (8).

DAB radio can significantly increase the number of radio stations available. The DAB signals are transmitted to most major cities, towns and motorway networks.

Unlike AM/FM radio, digital transmits several services on a single frequency. This group of services is known as an ensemble. There may be a number of ensembles receivable in some areas, each typically carrying between six and twelve services.

Digital radio is transmitted from regional and local transmitters. Some services are national or regional and are replicated on multiple transmitters throughout the region or country. Other services are local and only available within a limited range of one transmitter.

FINDING DIGITAL SERVICES

Press the Seek-up (9) or Seek-down (11) buttons to search the waveband to find the local active ensembles. Note: Alternatively the steering wheels buttons (20 and 21) perform the same function. A manual tuning function is also available, see **109, DAB MANUAL TUNING**.

The national channels use the same ensembles throughout a country and so there is usually no need to search for these. If you have stored your favourite national channels already then they will usually be found immediately on the same pre-set buttons.

If reception is lost when the vehicle is in motion, the vehicle may be moving out of range of the ensemble. Use the Seek-up (9) or Seek-down (11) buttons, or manual tuning, to search for services which are stronger in that area.

***Note:** If any auxiliary electrical equipment is connected to the vehicle, DAB radio reception capability may be reduced.*

SELECTING AND STORING DIGITAL SERVICES

Select DAB1 or DAB2. In each band, the active station will be the last one used. To select another station, press the appropriate preset button (0 to 9).

Any preset can be used to store any Digital Radio service, from any ensemble. If you switch between presets which are on different ensembles, the tuning time can take a few seconds (the word '**Searching....**' briefly appears on the screen). Switching between services within the same ensemble is virtually immediate.

If there is no service stored on a pre-set, or if the service is not receivable at the current location, the message '**No Reception**' will be displayed.

If the service you want is not already stored in a preset button or cannot be received, then you can step through the other services in the current ensemble by repeated short presses on the steering wheel buttons (20 or 21) or the seek-up or Seek-down buttons (9 or 11). At the end of the ensemble, a further press will show '**Searching....**' for a few seconds and then the next ensemble will be shown. You can then step through each service in this new ensemble by repeated short presses as above.

To store a service on a preset: While playing the desired service, press and hold the desired preset button. A bar-graph will show, indicating how long you need to hold the button, followed by a 'Preset Stored' pop-up message. Now release the button.

DAB SERVICE LIST

A quick way to see all the services available on the presets and all the other services which may be received in the current ensemble is to use the left navigation button (**10**) to go to the waveband list, select either DAB1 or DAB2, then the right navigation button to list the presets of DAB1 or DAB2. If the desired station is not listed, there is a **Service List** option at the top of the list. Scroll up to the **Service List** item and press the right navigation button to see all the services of the current ensemble listed. Use the navigation up/down buttons to scroll up and down the list. If you want to select a service, scroll the outline box onto the desired service and press **OK**.

DAB MANUAL TUNING

Press and hold the seek-up or seek-down buttons (**9** or **11**) or steering wheel buttons (**20** or **21**) for approximately 3 seconds to enter **Manual Tuning**. The **Manual Tuning** pop-up will appear on the display. Using the seek-up or seek-down buttons (**9** or **11**) or steering wheel buttons (**20** or **21**) you can then move through all the services and ensembles in turn.

If an ensemble is empty or not receivable then the tuning will move along to the next. If an ensemble is only just strong enough to receive but the services are too weak to use, the tuning may stop on that ensemble and display the ensemble's name, and possibly the service's name, but without sound. If no sound is heard within 5 to 10 seconds then press the appropriate seek button again to move onto the next useable ensemble.

To select and play a service of your choice, locate it and ensure that the audio is receivable, then press **OK**.

The **Manual Tuning** mode allows up to 30 seconds of inactivity before it times out. If **Manual Tuning** times out with no new service tuned, the radio will revert to the service you were tuned to at the start of your Manual Tuning session.

SERVICELINK

ServiceLink is an item on the Menu (**12**) and can be enabled or disabled using the **OK** button.

When ServiceLink is enabled, two additional features come in to operation:

- If you are listening to a local service which has a partner service in an adjacent area, when the signal weakens it will automatically changeover to new area's partner service.
- If you have selected a digital service which has an equivalent FM service in the area and your digital service has deteriorated, then the radio will automatically switch to the alternative FM service until the digital reception becomes adequate again.

We advise that ServiceLink is switched off when searching for ensembles or using Manual Tuning.

DAB DISPLAYED MESSAGES

'Searching....' is displayed when the radio is tuning itself to the correct ensemble. You will see this for a few seconds during some preset changes, and when seeking up or down to another ensemble.

If ServiceLink is enabled and no alternative signal can be found, 'Searching....' may show for a long period of time since in this mode the radio will continue to search round all the bands automatically until you command it to go to a different service or switch off ServiceLink.

'No Reception' is displayed when ServiceLink is not enabled and you have selected a service which cannot be received in the vehicle's current position. Select an alternative service, or search for an alternative ensemble.

'Serv00', 'Serv01' etc. may be shown when the radio can detect signals from an ensemble but cannot decode the service names. These are default labels to replace the non-receivable service names. In these cases the audio is generally impossible to receive from the vehicle's current location. Select an alternative service, or search for an alternative ensemble.

CD PLAYER



Do not use discs with paper labels, dual discs or DVDPlus discs. The front loading CD player may load and play this type of disc, however it is likely that the disc will not eject and will block the CD mechanism. Such damage to a CD player will not be covered under warranty.



Do not force the disc into the slot.

***Note:** Copy-protected CDs may fail to play in your CD changer or may be played subject to various limitations (e.g. sound quality may be impaired). If you experience a problem, try the CD in other players before contacting the CD vendor.*

LOADING A COMPACT DISC

Gently place a CD into the loading slot, the disc will be drawn into the player and loaded.

Press the CD button on the fascia to select CD playback mode.

If a CD is already loaded, playback will resume from the point of last play.

TRACK SELECTION

When playing a CD, the display will show the current track being played, the total number of tracks on the CD and the time elapsed since the current track began to play.

You can move to the previous or next track by briefly pressing the backwards or forwards seek buttons on either the audio unit or steering wheel.

Pressing and holding the seek buttons will fast forward or rewind the CD.

To select a track from the CD track list:

1. Press the right side of the menu navigation control (10) to access the CD track list.
2. Press the up or down arrows on the menu navigation control to scroll to the required track.
3. Press the **OK** button to play the selected track.

SHUFFLE

Repeat will play the current track repeatedly.

Shuffle plays the tracks in a random sequence.

To enable/disable Repeat or Shuffle when a CD is playing:

1. Press the **MENU** button (12).
2. Select **Audio Settings** on the screen menu.
3. Select **Repeat** or **Shuffle**.
4. Press **OK**.

PORTABLE MEDIA

Portable media devices can be connected to the media hubs located in the cubby box lid and the rear of the floor console. Compatible portable devices include:

- USB mass storage devices (e.g. a memory stick). Devices must use FAT or FAT32 file format.
- iPod® (iPod Classic, iPod Touch, iPhone™ and iPod Nano are supported - full functionality for older devices cannot be guaranteed). iPod Shuffle functionality cannot be guaranteed.

Note: iPod and iPhone are trademarks of Apple Inc., registered in the USA and other countries.

- Auxiliary devices (personal audio, MP3 players, all iPods).

Devices with Bluetooth® connectivity (devices must support A2DP and AVRCP Bluetooth® protocols).

When connecting a portable storage device, use the **AUX** button (5) button. Many of the controls are similar to those available CD play.



Please disconnect your iPod when leaving the vehicle. Failure to do so may result in the iPod battery discharging.

Note: The audio system will play MP3, WMA and AAC files.

To maximise playback quality, it is recommended that lossless compression is used for any media files on USB or iPod. Failing this, it is recommended that compressed files utilise a minimum bitrate of 192 kb/s (a higher bitrate is strongly recommended).

For media files delivered via USB or MP3 players, the highest compression rate supported, is 320 kbits per second (kbps). If anything less than 128 kbps is used, Digital Signal Processing (DSP) functionality may be lost.

Note: Some MP3 players have their own file system that is not supported by this system. To use your MP3 player, you must set it to USB Removable Device or Mass Storage Device mode. Only music that has been added to the device in this mode can be played.

CONNECTING A DEVICE

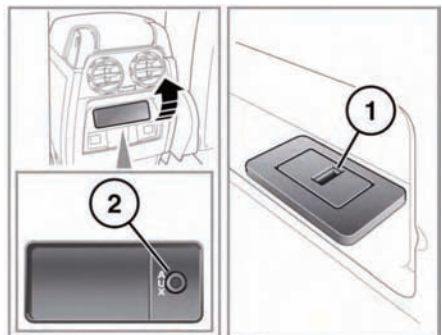

E136284

1. USB socket.
2. 3.5 mm AUX socket.

Connect the device into the appropriate socket.

Standard audio system

Note: Use the cable supplied with your media device to connect to the USB socket.

When an iPod is connected, playback will continue from the point at which it was last playing, provided the iPod battery is in a good state of charge.

When a USB or Bluetooth® device is already connected when **AUX** is selected, playback will continue from the point at which it was last playing.

Please refer to the Ownership section of the Land Rover website at www.landrover.com, for a list of compatible devices.

The Bluetooth® equipped devices listed on landrover.com have been tested for compatibility with Land Rover vehicles. Performance will vary, based on the device's software version and battery condition. Devices are warranted by their manufacturer, not Land Rover.



Do not plug non-audio devices into the USB port.

TELEPHONE SYSTEM



Switch off your telephone in areas with a high explosion risk. This includes filling stations, fuel storage areas or chemical factories, as well as places where the air contains fuel vapour, chemicals or metal dust.



Always stow your mobile phone securely.



The functioning of cardiac pacemakers or hearing aids may be impaired when the phone is in use. Check with a doctor or manufacturer whether any such devices you or your passengers are using, are sufficiently protected against high-frequency energy.

The Health Industry Manufacturers' Association recommends that a minimum separation of 15 cm (6 in) is maintained between a wireless phone antenna and a pacemaker, to avoid potential interference with the pacemaker. These recommendations are consistent with the independent research by, and recommendations of, Wireless Technology Research.

PAIRING AND DOCKING A MOBILE PHONE



Bluetooth® is the name for short-range radio frequency (RF) technology that allows electronic devices to communicate wirelessly with each other.

The Land Rover Bluetooth® system supports Bluetooth® Hands-Free Profile (HFP), Advanced Audio Distribution Profile (A2DP) and Audio Video Remote Control Profile (AVRCP).

Note: *HFP and A2DP/AVRCP profiles can be connected independently, so a phone can be connected via one, while a media device can be connected via the other, at the same time.*

Before making use of the vehicle's Bluetooth® phone system, your Bluetooth® phone must be paired and connected to the vehicle system.

Note: *The process of pairing and docking your phone with the vehicle using the mobile phone will vary depending on the type of mobile phone used.*

For telephone compatibility, see **148**, **TELEPHONE COMPATIBILITY**.

1. Switch the ignition on and ensure that the audio system is active and that no other phone is currently docked to the vehicle's Bluetooth® system.

- Using the mobile phone, search for Bluetooth® devices. On some phones, this is referred to as a new paired device. See your phone's operating instructions for further information.
- When the vehicle's Bluetooth® system is discovered (named Land Rover), select this device from the list.
- When prompted, enter the Bluetooth® PIN (Personal Identification Number) into the mobile phone. This four digit number is randomly generated by the vehicle system and will be displayed on the screen.
- Once your phone is paired and docked to the system, it can dock automatically. If it does not automatically dock, you will have to dock manually with the Land Rover Bluetooth system, via the mobile phone. Please consult the mobile phone's instructions for further information.

Note: Some mobile phones do not automatically dock and will require to be manually docked.

Some mobile phones require you to authorise the connection each time you start the system. To change this, you must set Land Rover as being authorised in the mobile phone's instructions for further information.

OPERATING THE PHONE

Each time the ignition is switched on the system will attempt to connect with the last connected phone.

As mobile phones have a wide range of audio and echo characteristics, it may take a few seconds for the vehicle system to adapt and deliver optimum audio performance. To achieve this, it may be necessary to reduce the in-vehicle volume and ventilation fan speed slightly. The same then applies when using the hands-free system.

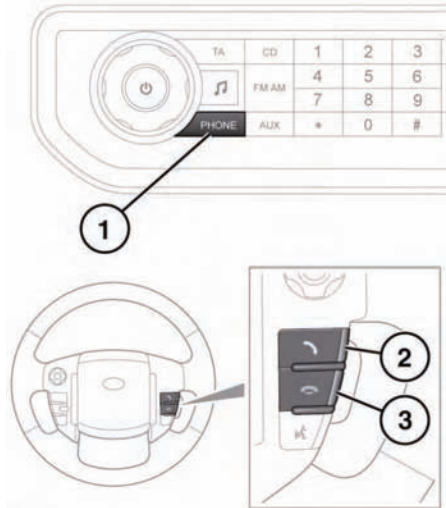

E136649

- Press to activate or deactivate the telephone menu.
- Press to answer a call or to dial a number.
- Press to end a call or to reject an incoming call.

Answering, rejecting or ending a call:

- Press the **PHONE** button (1) or the steering wheel control (2) to answer an incoming call.
- To reject or end a call, press the **PHONE** button or the appropriate steering wheel control (3).

Dialling:

- With **PHONE** selected, use the numeric keypad to enter a telephone number.
- Press **OK** on the audio control panel or the steering wheel phone control (2) to dial the number.

Call volume:

The phone call volume is operated by the audio system's volume control.

Standard audio system

If the audio system is in use when a phone call is active, the audio source is suppressed for the duration of the call. Parking aid warnings are not suppressed.

TIME AND DATE SETTINGS

To set/change the time and date:

1. Press the MENU button (**12**).
2. Select **Clock Settings** on the screen menu.
3. Select a clock function, make changes.
4. Once the change has been entered, press **OK**.

MP3 FILE PLAYBACK

MP3 discs have the potential to hold more music than a conventional CD, because each track can be compressed to a higher degree during recording.

The normal playing sequence on CDs with multiple folders, is to play the tracks within the top level first, then the tracks in any sub-folders.

***Note:** The CD player may take a long time to load an MP3 disc if it contains a lot of tracks.*

To select a track from the MP3 track list:

1. Press the right side of the menu navigation control (**10**) to access the currently playing MP3 folder.
If required, press the left side to access the folder list.
2. Press the up or down arrows on the menu navigation control to scroll to the required track or folder.
3. Press the **OK** button to play the selected track or open the selected folder.

MP3 SHUFFLE

When an MP3 CD is playing, playback options include **Repeat** and **Shuffle**.

TOUCH SCREEN HOME MENU

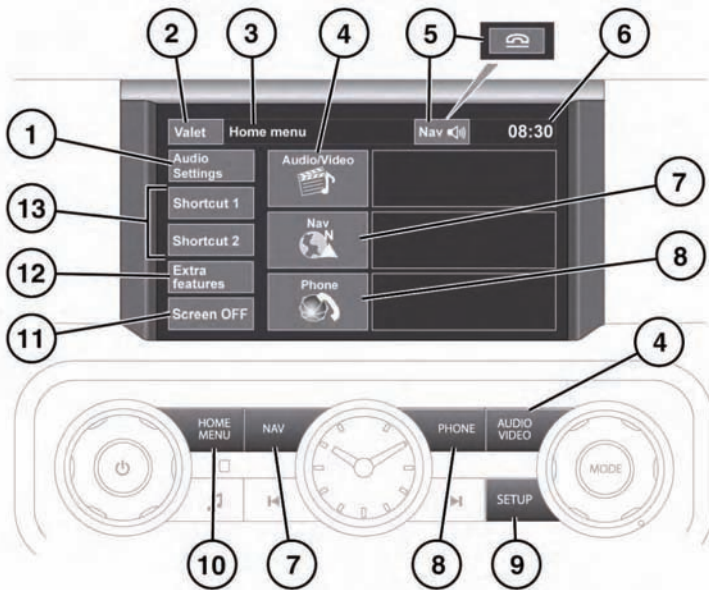

E135906

1. Touch to view the **Audio settings** menu.
2. Touch to select **Valet** mode.
3. Menu title.
4. Touch (soft key) or press (fascia button) to select the **Audio/Video** menu. An overview of current audio/video information is shown alongside the soft key.
5. Touch to end a call when using the phone, or to repeat the last given navigation instruction.
6. Time display. Touch to select time or date adjustment.
7. Touch (soft key) or press (fascia button) to select the **Navigation** menu. Current set destination is shown alongside the soft key.
8. Touch (soft key) or press (fascia button) to display the **Phone** menu.
9. Press to view the touch screen **Setup** menu.
10. Press to display the **Home** menu.
11. Touch to turn off the screen
12. Touch to access **Extra features** menu.
13. Home menu presets: 2 items can be selected as presets on the home menu. See **116, TOUCH SCREEN SETUP**.

Note: To enter/exit Valet mode, the correct PIN will need to be entered. See **117, SELECTING VALET MODE**.

TOUCH SCREEN USE



Always run the engine during prolonged use of the touch screen. Failure to do so may discharge the battery, preventing the engine from starting.



Avoid spilling or splashing liquids onto the touch screen.

The buttons on the fascia are referred to as **hard buttons** and should be pressed firmly. The touch screen buttons are referred to as **soft keys** and only require light pressure to function. Use only one finger and do not apply excessive pressure.

TOUCH SCREEN DISPLAY ICONS



Back soft key: Touch to return to the previous screen displayed.

TOUCH SCREEN CARE



Do not use abrasive cleaners on the touch screen. For approved cleaning products, contact your Dealer/Authorised Repairer.

TOUCH SCREEN SETUP

Select Setup using the **SETUP** button on the fascia.

Setup is divided into categories:

- Screen.
- System.
- Voice.

SCREEN SETTINGS

- **Volume pop-up:** Select to display Volume pop-up on or off.
- **Screensaver:** Select to change the screensaver. Touch an option to select.

***Note:** Screen animations will slow down the system response time.*

- **Screen animations:** Select to turn animated transitions between screens on or off.
- **Time out to home menu:** Sub menu selection screens can be set to revert to the **Home menu** after a pre determined length of time.
- **Theme:** Changes the appearance of the touch screen soft keys.

SYSTEM SETTINGS

- **Button feedback:** Soft key confirmation tone on or off.
- **Clock adjust:** Select 12 and 24 hour clock. Use the arrow soft keys to alter the time. Select **Date** to change the date, or to alter the date format (dd/mm or mm/dd). Select **Set**, to store new settings.
- **Home menu shortcuts:** Select to up to 2 items from the displayed list to appear as shortcuts on the **Home menu**. Select **Clear** to deselect highlighted items.
- **Language:** Select to change the vehicle Voice between **Male** and **Female** or to change the system language. Touch **Change** to select alternatives for Voice and text displays. Follow the on-screen instructions to confirm.

***Note:** Some languages are not yet available for both System display text and Voice control. In this event, it will be necessary to select a separate language for Voice control.*

- **Volume presets:** Select to alter the volume for the various audible systems (traffic and news announcements, parking aid, phone etc.).

VOICE SETTINGS

- **Command list:** View the categories and the acceptable voice commands.
Select an **Information** button to view alternative function commands.
- **Voicetags:** View the categories. Select a category to manage the voicetags for the chosen system. See **145, VOICETAGS**.
- **Operating guide:** View brief Voice system instructions. Select **Voice tutorial** for more detailed instructions (cancel via the displayed pop-up or by pressing and holding the voice button).
- Preferences: Select to alter the following settings:
 - **Voice profile:** The voice system can be trained to have a greater recognition of a particular voice or accent. The default setting is **Standard**. To build a voice profile for either **User 1** or **User 2**, it is necessary to complete a training program first.
To complete the training for the first time, select either **User 1** or **User 2** and follow the on-screen and audible instructions.
 - **Voice feedback:** Select **On** or **Off**.
 - **Feedback volume:** Adjust using the +/- buttons. It is not possible to reduce the volume to zero.
- **Voice training:** Select to access the voice system training program, designed to enable the system to better recognise the vocal characteristics of a user.
Select **User 1** or **User 2** and follow the on screen and audible instructions. See **145, VOICE TRAINING**.

The training session can be cancelled at any time by touching the on-screen pop-up or by pressing and holding the Voice button on the steering wheel. See **144, USING VOICE CONTROL**.

SELECTING VALET MODE

Valet mode allows the vehicle to be locked by a parking attendant, without giving access to the luggage compartment. Valet mode also prevents operation of the touch screen, to prevent access to telephone numbers or navigation addresses.

From the **Home** menu, select **Valet**:

Enter a four digit Personal identification Number (PIN) (personally chosen). On completion, touch the **OK** soft key.

If you wish to cancel the PIN, select **Delete**.

If the PIN is cancelled, or incorrectly entered, you will be prompted to enter the PIN again.

Valet mode activated is displayed to indicate that the PIN has been accepted.

The luggage compartment is now securely locked in Valet mode and the Valet mode On screen is displayed.

DESELECTING VALET MODE

When you enter the vehicle, touch the **Valet** button to view the Valet mode screen.

Enter your four digit PIN and touch the **OK** button.

Valet mode deactivated is displayed to indicate that your PIN has been accepted.

- The luggage compartment will return to the previously set security requirement.
- The touch screen will be enabled.

Note: If the PIN is forgotten, Valet mode can only be deactivated by your Dealer/Authorised Repairer.

EXTRA FEATURES

There are more features available than can be displayed at one time. This menu allows the selected features to be displayed, for example:

- **Ambient lighting:** While the headlamps are turned on, select this feature to turn ambient lighting on or off. Adjust the lighting level to suit. Adjusting to the minimum level will turn ambient lighting off. Selecting Auto allows the vehicle to control when and how ambient lighting is used.

Extra features are displayed in alphabetical order. Use the forward or back soft keys to move to the next screen.

AUDIO/VIDEO CONTROLS

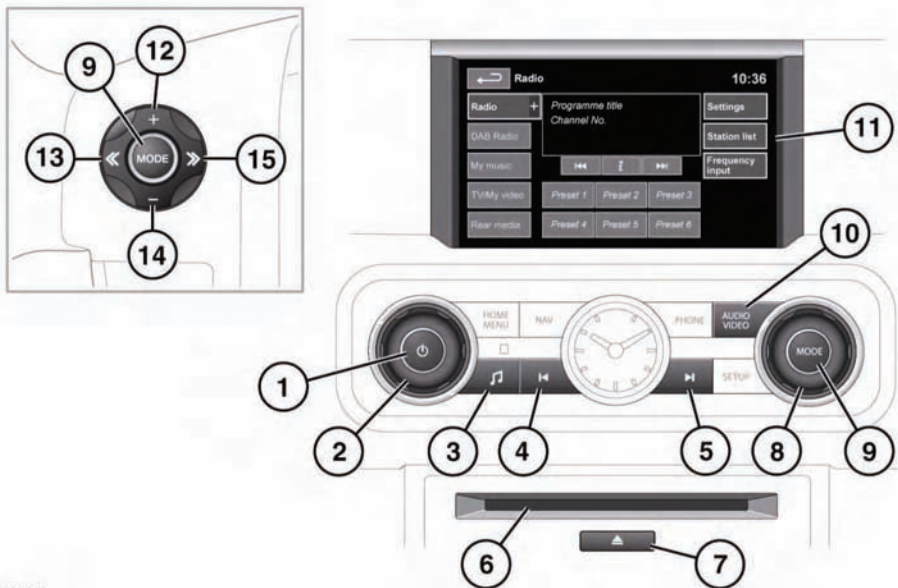

E135961



Sustained exposure to high sound levels can damage your hearing.

1. On/off and volume control: Press to switch the system on/off.

Note: *The audio system will operate with the ignition on or off, but will switch off with the ignition. Switch the audio on again if required.*

2. Volume: Rotate to adjust volume level.
3. Press to display the Audio settings.
4. Seek down: Short press to auto-seek to the previous radio station or previous track on chosen audio source.
5. Seek up: Short press to auto-seek to the next radio station or next track on chosen audio source.
 - Long press to activate manual-seek, scan forwards through a track.
6. CD slot.

7. Eject: Press to eject a CD.
8. Rotate to scroll through audio sources.
9. Mode: Press to view audio sources.
10. Audio/Video: Press to display the Audio/Video menu.
11. Touch screen.
12. Press to increase volume.
13. Press to scan down presets.
14. Press to decrease volume.
15. Press to scan up presets.

AUDIO SETTINGS

To view the audio settings menu, press the settings button (3) or the **Audio settings** soft key on the touch screen.

To adjust the sound settings:

- Touch the + or - soft keys to adjust Bass, Treble or Subwoofer levels.

Audio/video overview

- If surround sound is fitted, touch the appropriate soft key to select the required surround sound option.

Note: Surround sound options are not available for certain sources where the surround sound mode is set automatically.

To adjust balance and fade:

1. From the Sound settings menu, select **Balance/Fade**.

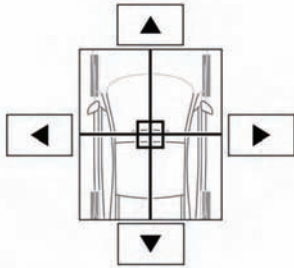

E132537

2. Touch the arrow soft keys to move the sound focal point to the desired area of the vehicle (the focal cross-hairs will appear red when not in the default position).

LICENSING



E132527



E132539

Manufactured under license from Dolby Laboratories.

Dolby and the double-D symbol are trademarks of Dolby Laboratories.



E132540

Manufactured under license under U.S. Patent #'s: 5,451,942; 5,956,674; 5,974,380; 5,978,762; 6,487,535; 7,003,467 & other U.S. and worldwide patents issued & pending. DTS, the Symbol, and Neo:6 are registered trademarks, & DTS Digital Surround and the DTS logos are trademarks of DTS, Inc. Product includes software. © DTS, Inc. All Rights Reserved.



E132541



E132542

Manufactured under license under U.S. Patent #'s: 5,451,942; 5,956,674; 5,974,380; 5,978,762; 6,487,535 & other U.S. and worldwide patents issued & pending. DTS and the Symbol are registered trademarks, & DTS 2.0+ Digital Out and the DTS logos are trademarks of DTS, Inc. Product includes software. © DTS, Inc. All Rights Reserved.



E132543

DivX Certified® to play DivX® video.

DivX®, DivX Certified® and associated logos are registered trademarks of DivX, Inc. and are used under license.

ABOUT DIVX VIDEO: DivX® is a digital video format created by DivX, Inc. This is an official DivX Certified device that plays DivX video. Visit www.divx.com for more information and software tools to convert your files into DivX video.

ABOUT DIVX VIDEO-ON-DEMAND: This DivX Certified® device must be registered in order to play DivX Video-on-Demand (VOD) content. To generate the registration code, locate the DivX VOD section in the device setup menu.

1. Follow the route, Home Menu - Audio Video - TV/My video - Settings - VOD.
2. An eight digit code will be displayed. This is your unique DivX code. Make a note of this code and keep it for future reference.

Go to vod.divx.com with this code to complete the registration process and learn more about DivX VOD.

Covered by one or more of the following U.S. Patents: 7,295,673; 7,460,668; 7,519,274.



E132544

Music and video recognition technology and related data are provided by Gracenote®. Gracenote is the industry standard in music recognition technology and related content delivery. For more information, please visit www.gracenote.com.

CD, DVD, Blu-ray Disc, and music and video-related data from Gracenote, Inc., copyright © 2000 to present Gracenote. Gracenote Software, copyright © 2000 to present Gracenote. One or more patents owned by Gracenote apply to this product and service. See the Gracenote website for a non-exhaustive list of applicable Gracenote patents. Gracenote, CDDB, MusicID, MediaVOCS, the Gracenote logo and logotype, and the "Powered by Gracenote" logo are either registered trademarks or trademarks of Gracenote in the United States and/or other countries.

GRACENOTE® END USER LICENSING AGREEMENT

This application or device contains software from Gracenote, Inc. of Emeryville, California (“Gracenote”). The software from Gracenote (the “Gracenote Software”) enables this application to perform disc and/or file identification and obtain music-related information, including name, artist, track, and title information (“Gracenote Data”) from online servers or embedded databases (collectively, “Gracenote Servers”) and to perform other functions. You may use Gracenote Data only by means of the intended End-User functions of this application or device.

You agree that you will use Gracenote Data, the Gracenote Software, and Gracenote Servers for your own personal non-commercial use only. You agree not to assign, copy, transfer or transmit the Gracenote Software or any Gracenote Data to any third party. **YOU AGREE NOT TO USE OR EXPLOIT GRACENOTE DATA, THE GRACENOTE SOFTWARE, OR GRACENOTE SERVERS, EXCEPT AS EXPRESSLY PERMITTED HEREIN.**

You agree that your non-exclusive license to use the Gracenote Data, the Gracenote Software, and Gracenote Servers will terminate if you violate these restrictions. If your license terminates, you agree to cease any and all use of the Gracenote Data, the Gracenote Software, and Gracenote Servers. Gracenote reserves all rights in Gracenote Data, the Gracenote Software, and the Gracenote Servers, including all ownership rights. Under no circumstances will Gracenote become liable for any payment to you for any information that you provide. You agree that Gracenote, Inc. may enforce its rights under this Agreement against you directly in its own name.

The Gracenote service uses a unique identifier to track queries for statistical purposes. The purpose of a randomly assigned numeric identifier is to allow the Gracenote service to count queries without knowing anything about who you are. For more information, see the web page for the Gracenote Privacy Policy for the Gracenote service.

The Gracenote Software and each item of Gracenote Data are licensed to you “AS IS.” Gracenote makes no representations or warranties, express or implied, regarding the accuracy of any Gracenote Data from in the Gracenote Servers. Gracenote reserves the right to delete data from the Gracenote Servers or to change data categories for any cause that Gracenote deems sufficient. No warranty is made that the Gracenote Software or Gracenote Servers are error-free or that functioning of Gracenote Software or Gracenote Servers will be uninterrupted. Gracenote is not obligated to provide you with new enhanced or additional data types or categories that Gracenote may provide in the future and is free to discontinue its services at any time.

GRACENOTE DISCLAIMS ALL WARRANTIES EXPRESS OR IMPLIED, INCLUDING, BUT NOT LIMITED TO, IMPLIED WARRANTIES OF MERCHANTABILITY, FITNESS FOR A PARTICULAR PURPOSE, TITLE, AND NON-INFRINGEMENT. GRACENOTE DOES NOT WARRANT THE RESULTS THAT WILL BE OBTAINED BY YOUR USE OF THE GRACENOTE SOFTWARE OR ANY GRACENOTE SERVER. IN NO CASE WILL GRACENOTE BE LIABLE FOR ANY CONSEQUENTIAL OR INCIDENTAL DAMAGES OR FOR ANY LOST PROFITS OR LOST REVENUES.

© Gracenote, Inc. 2009

RADIO CONTROLS

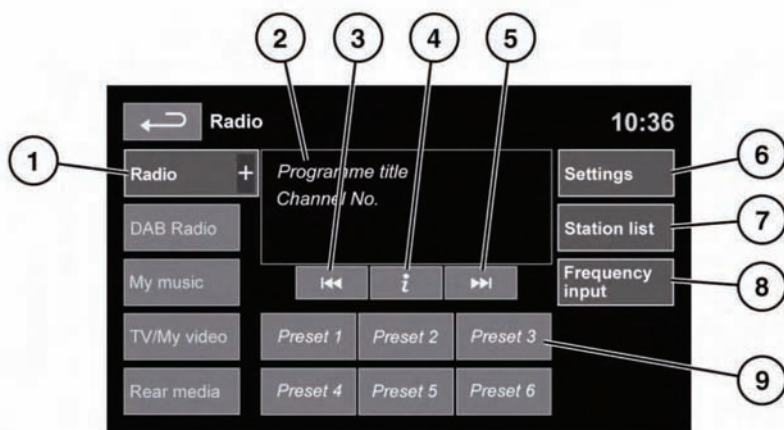

E135965

1. Waveband selection: Touch to view and select a waveband. The radio will tune to the last used station on that waveband. The waveband selection box will close after 5 seconds without use.
2. Displays information about the current station. Some of this information is also displayed in the instrument panel.
3. Seek down: Short touch to auto seek down the frequency to the next radio station.
 - Long touch to activate manual seek mode. Further short touches change the frequency in single decrements. A further long touch will scan backwards through the current waveband until the soft key is released.
4. Radio text: If selected, the radio text broadcast by the radio station will be displayed in a pop-up.
5. Seek up: Short touch to auto seek up the frequency to the next radio station.
 - Long touch to activate manual seek mode. Further short touches change the frequency in single increments. A further long touch will scan forwards through the current waveband until the soft key is released.
6. Radio settings: Touch to view and activate/deactivate the following features: **RDS, Traffic, News, AF** and **REG**. See **124, RADIO DATA SYSTEM (RDS)**.
7. Station list (FM only): Select to view a list of all available stations on the waveband. The list can be sorted by **Frequency, Name** or **Category** (pop, news, sport etc.), by selecting the appropriate soft key. Touch to select the chosen station.

If the stations are sorted by category, touch the chosen category to view and select a corresponding station.
8. Frequency input: Select to enter a known frequency of a station on the current waveband, using the numeric keypad that appears. Select **OK** or wait for 2 seconds to tune to the entered frequency.

9. Station presets: Each waveband has 6 preset positions.
 - Touch and release to tune to the station stored on that preset.
 - Touch and hold to store the current station on that preset (the radio will mute while the station is stored).
 - Use the seek buttons on the steering wheel to change to the next or previous preset station.

RADIO DATA SYSTEM (RDS)

Your radio is equipped with RDS which enables the audio unit to receive additional information with normal FM radio signals.

Note: *Not all FM radio stations broadcast RDS information.*

Select **Settings (6)** to view or alter RDS settings.

- **Traffic/News:** Provides local travel or news information.
- **Regionalisation (REG):** Select to prevent the radio tuning into an alternative local station that has a stronger signal.
- **Alternative Frequency (AF):** Select to allow the radio to automatically re-tune to a stronger alternative frequency for the current station. This is useful on journey where the vehicle travels through different transmitter areas.

DAB RADIO CONTROLS

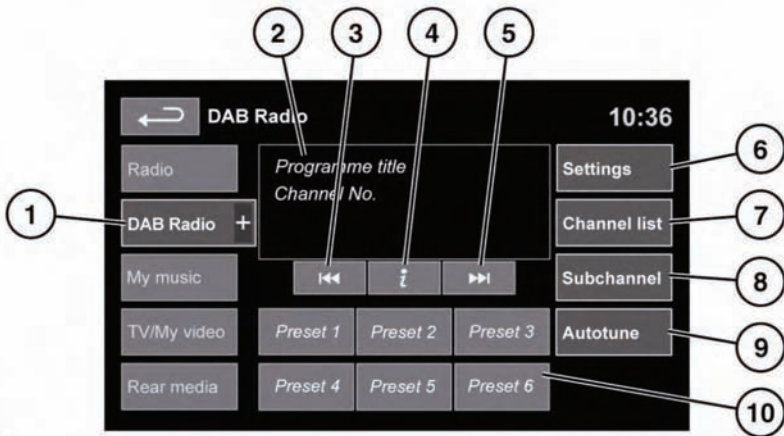

E135996

- DAB band selection:** Touch to view and select a DAB band (**DAB 1, 2 or 3**). The radio will tune to the last used channel on that band. Touch again to close.

The DAB band selection box will close after 5 seconds without use.
- Display showing the current channel, the associated Ensemble and relevant DAB radio text.**
- Seek down:** Short touch to seek previous available channel.

 - Long touch to seek previous available Ensemble. The first channel in the new Ensemble will be selected.
- Channel information:** Touch to view DAB text and channel information.
- Seek up:** Short touch to find the next available channel.

 - Long touch to find the next available Ensemble. The first channel in the new Ensemble will be selected.
- Settings:** Touch to view the Settings menu:

 - **Options:** Select to activate/deactivate FM Traffic and DAB Link and to alter DAB country and format settings (with vehicle stationary).
 - **Announcements:** Select an alarm announcement and up to 3 other announcement types (traffic, news etc.) from the list. The selected announcements will interrupt the current programme when broadcast.
 - **Audio settings:** Select to enter the audio settings menu (see **119, AUDIO SETTINGS**).
- Channel list:** Touch to view a list of available Ensembles and channels. The list can be sorted by **Ensemble, Channel, Subchannel** or by **Category**.

 - If an **Ensemble** is selected from the list, all available channels from that ensemble will be displayed.
 - Sorting by **Subchannel** is only available when the current channel is

broadcasting subchannels.

- If **Category** is selected, touch the chosen category to view corresponding channels, before making your selection from the list.

Once the desired selection has been made, select the Back soft key to return to the main DAB menu.

8. Subchannel tier: If subchannels are broadcast by the current channel, this soft key will be active. Select to view available subchannels and then select the chosen subchannel from the list.
9. Autotune: Select to scan for all available DAB Ensembles/channels. This needs to be done before using the DAB radio for the first time.

Autotune is also useful when travelling long distances, so regional Ensembles can be tuned.

During Auto-tune, a pop-up shows tuning progress.

The Autotune process will not affect current presets, but some presets may not operate if the channel they relate to is no longer available (**No reception** displays).

10. Station presets: Each DAB band has 6 preset positions.
 - Touch and release to tune the radio to the station stored on that preset.
 - Touch and hold to store the current station on that preset (the radio will mute while the station is stored).
 - Use the seek buttons on the steering wheel to select the next or previous preset station.

Note: *If you attempt to select a preset channel that is now unavailable or invalid, **No channel found** is displayed.*

DIGITAL RADIO RECEPTION

DAB radio can significantly increase the number of radio channels/stations available. The DAB signals are transmitted to most major cities, towns and motorway networks.

Digital radio is transmitted from regional transmitters. Some local channels are not available outside the range of their transmitters. If you want to listen to local channels as you move around the country, use the auto-tune function (AUTO) to build new channel lists.

Note: *If any auxiliary electrical equipment is connected to the vehicle, then this may reduce the DAB radio sound quality.*

ENSEMBLES

Unlike AM/FM radio, DAB transmits several channels/stations on a single frequency. A group of channels is known as an ensemble. Some channels within the ensemble may have subchannels offering several listening options.

If reception is lost when the vehicle is in motion, the vehicle may be out of range of the ensemble. To build a new list of ensembles, select **Autotune**.

LOADING COMPACT DISCS

- ⓘ Do not force the disc into the slot.
- ⓘ Do not use irregular shaped CDs and CDs with a scratch protection film or self-adhesive labels attached.
- ⓘ The CD unit will play compact discs that conform to the international Red Book standard audio specification. Playback of CDs not conforming to this standard cannot be guaranteed.
- ⓘ Recordable (CD-R) discs and re-writable (CD-RW) discs may not function correctly.
- ⓘ Dual format, dual-sided discs (DVD Plus, CD-DVD format) are thicker than normal CDs and consequently playback cannot be guaranteed and jamming may occur.

It is recommended that only high quality 12 cm (4.7 in.) circular discs are used.

The unit will play Compact Disc Digital Audio (CDDA) discs, MP3, WMA, WAV and AAC files.

The CD player will accommodate one disc at a time but up to 10 CDs can be uploaded to the virtual store.

Only CDDA discs can be loaded into the virtual CD store.

To locate the CD load slot and the eject button, see **119, AUDIO/VIDEO CONTROLS**.

MP3 FILE PLAYBACK

If an MP3 CD is to be used, each session must be properly closed but the whole disc does not have to be finalised.

When Browse is selected, the list of folders and MP3 files is displayed. Select a folder to view and select the tracks contained within.

- The highest compression rate supported is 320k bits per second (kbps). If anything less than 128 kbps is used, Digital Signal Processing (DSP) functionality may be lost.
- The CD player may take a longer time to load an MP3 disc if there are more tracks than on a normal CD. To minimise loading time, a rigid folder structure is recommended.
- If a CD contains a mixture of MP3 and CDDA tracks, any MP3 tracks will be ignored.

CD PLAYER CONTROLS

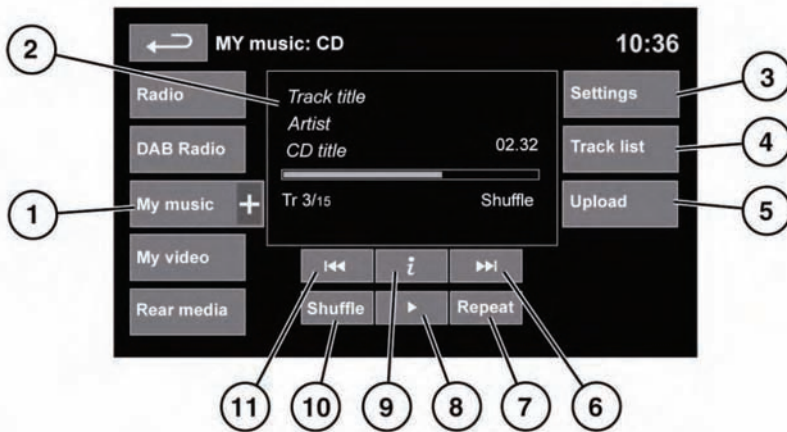

E135986

Having selected the CD option, see **132**,

PORTABLE MEDIA CONTROLS

1. Touch to select playback from either the current CD or from CDs uploaded onto the virtual CD store.
2. Display of information about the current track, including elapsed run-time. Some of this information is also displayed in the instrument panel.
3. Select to switch traffic and news announcements on or off, or change the page jump setting.
4. Select to view the track list of the current CD or virtual CD. Select a track from the list to start playback. This is displayed as a Browse soft key on some screens.
5. Select to view and manage the CDs loaded onto the virtual store.
 - Select **Upload** alongside an empty slot to upload the current CD.
 - If the virtual store is full, select **Replace** to overwrite an existing CD.
6. Skip/Scan forward: Touch and release to skip to the next track on the current CD.
 - Touch and hold to scan forwards through the current track. Playback will resume when the soft key is released.

In each case a confirmation pop-up will appear. Select **Yes** to continue.
7. Repeat: Touch and release once to repeat the current track continuously until Repeat mode is cancelled. **Repeat track** is displayed.
 - Touch and release again to repeat the current virtual CD (or folder for MP3 discs) continuously until Repeat mode is cancelled. **Repeat disc** is displayed.
 - Touch and release a third time to cancel Repeat mode.

Note: Selecting **Shuffle (10)** will cancel Repeat mode but **Repeat track** can be selected with Shuffle mode active (cancels the previously selected shuffle mode).
8. Pause/Play: Select to pause playback. Select again to resume playback.

9. Select to view more detailed information about the current track.
10. Shuffle: Touch and release once to play random tracks on the current CD (MP3 folder). **Shuffle disc** is displayed.
 - Touch and release again to play random tracks from all virtual CDs (MP3 disc). **Shuffle all** is displayed.
 - Touch and release a third time to cancel Shuffle mode.
11. Skip/Scan backward: Touch and release within 3 seconds of track playback to skip to the previous track.
 - Touch and release after 3 seconds of track playback to skip to the beginning of the current track.
 - Touch and hold to scan backwards through the current track. Playback will resume when the soft key is released.

PORTABLE MEDIA CONNECTIONS

Portable media devices can be connected to the media hubs located in the cubby box lid and the rear of the floor console. Compatible portable devices include:

- USB mass storage devices (e.g. a memory stick). Devices must use FAT or FAT32 file format.
- iPod (iPod Classic, iPod Touch, iPhone and iPod Nano are supported - full functionality for older devices cannot be guaranteed). iPod Shuffle functionality cannot be guaranteed.

Note: *iPod and iPhone are trademarks of Apple Inc., registered in the USA and other countries.*

- Auxiliary devices (personal audio, MP3 players, all iPods).

If you are connecting an iPod, mass storage or Bluetooth® device, use the touch screen to operate and search the device. Many of the controls are similar to those available for CD play.

 Please disconnect your iPod when leaving the vehicle. Failure to do so may result in the iPod battery discharging.

Note: *The audio system will play MP3, WMA and AAC files.*

To maximise playback quality, it is recommended that lossless compression is used for any media files on USB or iPod. Failing this, it is recommended that compressed files utilise a minimum bitrate of 192 kb/s (a higher bitrate is strongly recommended).

Note: *Some MP3 players have their own file system that is not supported by this system. To use your MP3 player, you must set it to USB Removable Device or Mass Storage Device mode. Only music that has been added to the device in this mode can be played.*

CONNECTING A DEVICE

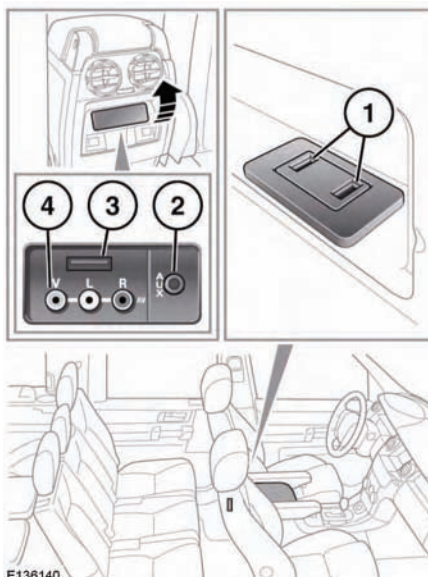

1. USB sockets.
2. 3.5 mm AUX socket.
3. Rear media USB socket.
4. Rear media AV sockets.

Connect the device into the appropriate socket.

When an iPod is connected, playback will continue from the point at which it was last playing, provided the iPod battery is in a good state of charge.

When a USB or Bluetooth® device is connected, playback will continue from the point it was last played. If a device is already connected when **AUX** is selected, playback will continue from the point at which it was last playing.

Please refer to the Ownership section of the Land Rover website at www.landrover.com, for a list of compatible devices.

The Bluetooth® equipped devices listed on landrover.com have been tested for compatibility with Land Rover vehicles. Performance will vary, based on the device's software version and battery condition. Devices are warranted by their manufacturer, not Land Rover.



Do not plug non-audio devices into the USB port.

Note: *You cannot use a USB hub to connect more than one USB device to the audio unit.*

Note: *Devices connected to the USB ports will be charged, but devices that are fully discharged will not play.*

Note: *Options such as **Repeat** and **Mix** relate to the device currently playing, they will not apply to any subsequent device.*

PORTABLE MEDIA CONTROLS

For Premium audio system controls, see **104, STANDARD AUDIO SYSTEM CONTROLS**

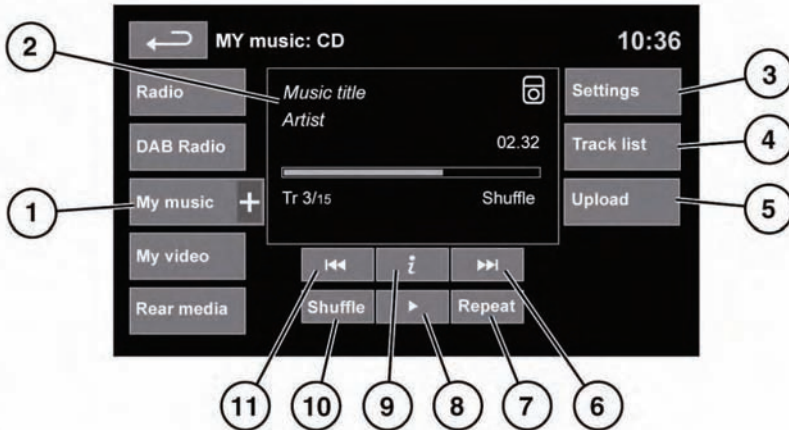

E135992

My music includes CD, iPod, USB, AUX and Bluetooth® devices. The full infotainment system also includes Stored CD.

1. Touch the **My Music +** icon to display all options. Select an option.

Note: Sound quality and volume levels available from devices connected to the auxiliary input may vary widely.
2. Display of information about the current track, including elapsed run-time. Some of this information is also displayed in the instrument panel.
3. **Settings:** Select to switch traffic and news announcements on or off. Additionally, for MP3 recorded media, you can select the number of list entries that are skipped when you use the page up/down arrows when navigating a list.
4. Depending on the selected mode, this soft key will be either **Track list** or **Browse**. In Stored CD mode, both soft keys will be displayed.

Track list. Select to view current CD or Stored CD track list. Select a track to start playback.

Browse. (iPod, USB and Stored CD modes only).

- Select to view the contents of the connected device which are displayed as dictated by the file structure.
 - Select a file to start playback (Browse view will remain). Select a folder or subfolder to view their contents.
 - To return to the Controls menu, select the Back soft key.
5. **Upload:** Applicable to Stored CD menu only. Select to view and manage the CDs loaded onto the CD store.
 - Select **Upload** alongside an empty slot to upload the current CD. There are 10 slots available.
 - If the CD store is full, select **Replace** to overwrite an existing CD.

In each case a confirmation pop-up will appear. Select **Yes** to continue.

Note: Loading time is dependent on content type. A % count up is displayed. Other features can be selected while upload is in progress.

6. Skip/Scan forward:

- Touch and release to skip to the next track.
- Touch and hold to scan forwards through the current track. Play will resume when the soft key is released.

7. Repeat:

In **CD** mode

- Touch and release to repeat the current track continuously until Repeat mode is cancelled. **Repeat track** is displayed.
- Touch and release again to repeat the current Stored CD (or folder for MP3 discs) continuously until Repeat mode is cancelled. **Repeat disc** or **Repeat folder** is displayed.
- Touch and release a third time to cancel Repeat mode.

Note: Selecting **Shuffle (10)** will cancel Repeat mode, but Repeat track can be selected with Shuffle mode active (cancels the previously selected shuffle mode).

In **USB** or **iPod** mode

- Select to repeat the current track.
- Select again to repeat the current folder (USB) or to cancel repeat mode (iPod). Select again to cancel repeat mode in USB.

Note: Repeat mode is not available for Bluetooth® devices.

Note: Selecting **Shuffle (10)** will cancel Repeat mode.

8. Pause/Play: Select to pause playback.

Select again to resume playback.

9. Information: More information about the current track.

10. Shuffle:

- Touch and release once to play random tracks from the current CD, MP3 folder, USB folder or iPod playlist. A **Shuffle** message is displayed.
- Touch and release again to play random tracks from CD, MP3 disc, USB folders or tracks on the media device or tracks loaded onto the CD store. **Shuffle all** is displayed.
- Touch and release again to cancel Shuffle mode.

11. Skip/Scan backward:

- Touch and release within 3 seconds of track playback to skip to the previous track.
- Touch and release after 3 seconds of track playback to skip to the beginning of the current track.
- Touch and hold to scan backwards through the current track. Playback will resume when the soft key is released.

PLAYING A PORTABLE DEVICE

If you are using a USB mass storage device or approved iPod, you can control playback using the touch screen controls.

If you are using a Bluetooth® device, you can control playback using the touch screen, but some controls are unavailable.

If you are using any portable media device via the AUX socket, then you must control playback from the device itself.



Land Rover does not recommend the use of a Hard Disc Drive via the USB link while the vehicle is in motion. These devices are not designed for in car use and may be damaged.

CONNECTING MULTIPLE DEVICES



Do not plug non-audio devices into the USB port.

You can connect multiple devices simultaneously to the portable media interface and switch between them using the touch screen. Select **iPod**, **USB**, **Bluetooth** or **AUX**, to switch between modes.

The device docked first will remain the active device until you choose to change.

If, after changing to the newly-docked device, you change back to the first device, play will resume at the point you left it (USB and iPod only).

Note: You cannot use a USB hub to connect more than one USB device to the audio unit.

Note: Devices connected to the iPod and USB ports will be charged, but devices that are fully discharged will not play.

Note: Options such as **Repeat** and **Shuffle** relate to the device currently playing, they will not apply to any subsequent device.

PAIRING AND CONNECTING USING THE MEDIA PLAYER

For further information on Bluetooth®, see **148, BLUETOOTH® INFORMATION**.

Note: The process of pairing and connecting your media device with the vehicle, using the media device, will vary depending on the type of media device.

1. Switch on the ignition and ensure the touch screen is active.
2. From the Home menu, select **Audio/Video**, then **My Music**.
3. A menu will appear. Select **Search new**.
4. Select **Device to vehicle** option.

Note: The vehicle's Bluetooth® system is only discoverable for 3 minutes.

5. Using the media device, search for Bluetooth® devices. On some media devices, this is referred to as new paired device. See your media device's operating instructions for further information.
6. When the vehicle's Bluetooth® system is discovered, follow the on-screen instructions. Select **Yes** when prompted, to confirm the pairing.

Either your device or the vehicle system will ask for a PIN (Personal Identification Number). When prompted, enter a PIN of your choice and select **OK** to confirm.

7. Enter the same PIN into the other device.
8. Once your device is paired and connected to the system, a confirmation message will be displayed, before switching to the My music: Bluetooth screen.

Note: Some media devices do not automatically connect and need to be manually connected, via the device or by using the **Change device** option.

PAIRING AND CONNECTING A BLUETOOTH® DEVICE USING THE TOUCH SCREEN

For further information on Bluetooth®, see **148, BLUETOOTH® INFORMATION**.

1. Switch on your device's Bluetooth® connection. Make sure that it is in Bluetooth® discoverable mode, sometimes referred to as find me mode (see your device's operating instructions for more information).
2. Switch on the ignition and ensure the touch screen is active.
3. From the Home menu, select **Audio/Video**, then **My Music**.
4. A menu will appear. Select **Search new**.
5. Select **Vehicle to device** option.

6. Identify your device from the displayed list and select the corresponding **Pair and connect** option.

***Note:** If more than 5 devices are detected, it may be necessary to use the scroll bar to see the entire list.*

7. When prompted, enter the PIN (Personal Identification Number) code into your device. See your device's operating instructions for more information.
8. Once your device is paired and connected to the system, a confirmation message will be displayed before switching to the My music: Bluetooth screen.

***Note:** Due to the duration of a Bluetooth® search, it is advised that the time-out to home screen feature is switched off before attempting to search for Bluetooth® devices. This setting can be changed within **Set-up, Screen, Time out home**.*

AUTOMATIC BLUETOOTH® RECONNECTION

If devices have already been paired and connected, when Bluetooth® is selected from the My music menu, the system will automatically connect to the last used device (a confirmation pop-up appears). If the last used device is not present, then the system will search for other previously connected devices and automatically connect if one is found.

If no previously connected device is found, **Please connect device** is displayed and the **Change device** option is given.

LOSS OF CONNECTION

If a loss of connection between the vehicle and the Bluetooth® device occurs, a pop-up is displayed. Select **Reconnect** to automatically restore the connection. A confirmation pop-up will appear before the touch screen reverts to its previous mode.

CHANGING/DISCONNECTING A DEVICE

1. From the menu, select **Change device**.
2. Select **Disconnect**. A confirmation pop-up will appear and then you will be given the option to **Search new** or select a different device from the list of paired devices.

TELEVISION CONTROLS

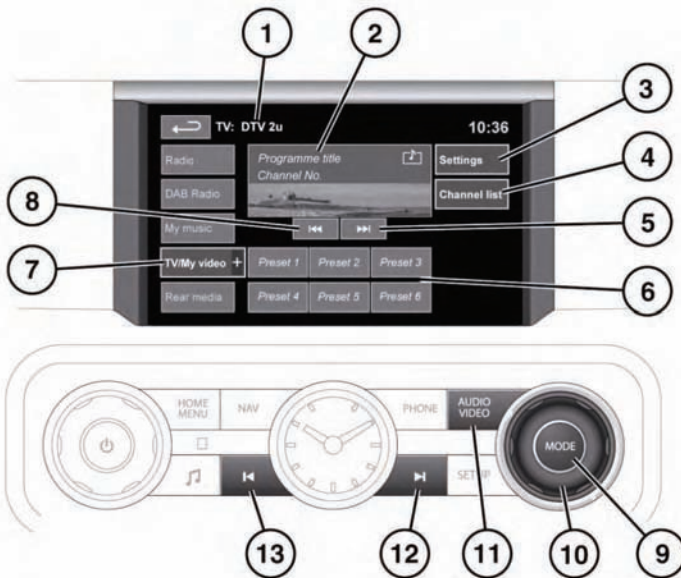

E135931

1. Programme information.
2. Preview screen for TV programme: Touch to select full screen mode.
Short touch the screen again to view the controls and Electronic Programme Guide (EPG) information at any time.
To return to preview mode, touch and hold the full screen view.
3. **Settings:** Select to switch Traffic and News announcements on or off, or to select an alternative country analogue TV format, if necessary, when travelling abroad.
Note: Digital TV is not affected by a change of country.

4. **Channel list:** Select to view an alphabetical list of all TV channels currently available.
 - A small preview of the current channel and programme title is also displayed.
 - Touch a listed channel to change the preview and title to the new channel.
 - Touch the preview to view that channel.

Note: As the TV system is continually checking the availability of channels, it is possible for a channel to be in the list, but not actually available (e.g. when driving through different transmitter regions).
After a country format change, the channel list will be empty until the system has scanned all channels at least once.
5. Seek up: Select to view the next channel on the TV channel list.

6. TV channel presets:

- Touch and hold to store the current channel as a preset. The channel name will then be displayed on the soft key.
- Briefly touch to select the channel stored on that preset.

Note: *Stored presets contain information identifying the country where the preset was stored. When a preset is selected, the TV format of the country where the preset stored will be adopted. As analogue TV formats differ in different countries, this may create a situation where the analogue channel list is empty.*

7. TV/My video: TV band/video input selection. Touch to view and select either digital (**DTV 1** or **DTV 2 - Digital**) or analogue (**TV - Analogue**) TV reception.

From this menu, it is also possible to select other forms of media input (**DVD/CD**) provided the relevant media is present. The selected option will be displayed.

When changing between analogue and digital bands, the last tuned channel on the new band will be displayed. When changing between digital bands, the current channel will be displayed.

Note: *After 5 seconds without use, the TV/My video menu will close.*

8. Seek down: Select to view the previous channel on the TV channel list.
9. Press to view alternative audio sources.
10. Rotate to scroll through audio sources.
11. Press to access the main TV/DVD menu.
12. Press to forward search TV channels.
13. Press to backward search TV channels.

For information on the use of the audio/video controls on the audio unit and steering wheel, see **119, AUDIO/VIDEO CONTROLS**.

ANALOGUE/DIGITAL TELEVISION

The TV offers both analogue and digital TV reception. You can switch between the two modes using the touch screen controls.

- From the TV/My video menu, select **TV/My video** again or touch the + button alongside.
- Select the desired option from **DTV 1** or **DTV 2 - Digital** or **ATV - Analogue**. There is no difference in the reception mode between DTV 1 and DTV 2. The preset list is the only thing that changes.

FULL SCREEN VIEW

The TV main menu and the channel list display a small preview picture of the current channel. Touch the preview to select full screen mode. The TV controls and Electronic Program Guide (EPG) information (digital TV only) are displayed for 5 seconds before disappearing.

Short touch the screen again to view the controls and EPG information at any time.

To return to preview mode, touch and hold the full screen view.

FULL SCREEN VIEW CONTROLS

The seek controls operate in the same manner as they do in preview mode.

Analogue TV display format: Use the relevant soft key to select the **4:3**, **16:9** or **Zoom** option.

Digital TV display format: The picture can be displayed in either the correct format as transmitted by the broadcaster (either **4:3** or **16:9**) or select **Zoom** to magnify the picture.

VIDEO MEDIA PLAYER CONTROLS

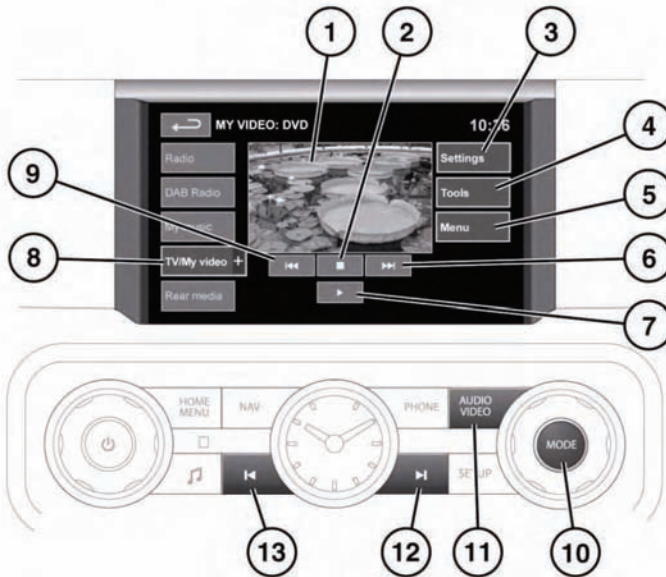

E135930

- 1.** Preview screen for video media information: Touch to select full screen mode.
Briefly touch the screen again to view the controls at any time.
To return to preview mode, touch and hold the full screen view.
- 2.** Select to pre-stop playback. A second touch will stop and reset the DVD.
- 3. Settings:** Depending on the video media specification, there are 2 sub-menus within settings: **Options** and **VOD** (Video On Demand).
VOD allows playing of DivX VOD content from a video media. The eight digit registration code will be displayed when the VOD soft key is touched.
The player must also be registered with DivX. See **120, LICENSING**.
- 4. Tools:** The following options can be selected:
 - **GOTO:** The GOTO menu allows you to access specific parts of the video, by **Chapter** or **Title number**.
 - Subtitles.
 - Angle.
 - Audio.
- 5. Menu:** Select to view the Video media menu. On some screens this may be replaced by a **Browse** soft key.
- 6.** Seek up: Select to view the next DVD chapter or previous chapter of the video media.
- 7.** Select to start/restart play.
- 8. TV/My video:** TV band/video input selection. Touch the + icon to view and select DVD or other forms of video media (**CD/USB**), provided the relevant media is





present. The selected option will be displayed.

Note: After 5 seconds without use, the TV/My video menu will close.

9. Seek down: Select to view the previous DVD chapter or previous chapter of the video media.
10. MODE button: Press to view alternative audio sources, rotate to select a source.
11. AUDIO VIDEO button: Press to access the main TV/DVD menu.
12. Press to forward search.
13. Press to backward search.

For information on the CD/DVD loading slot and the eject button, and the use of the audio/video controls on the audio unit and steering wheel, see **119, AUDIO/VIDEO CONTROLS**.

LOADING DVDs

-  Do not force the disc into the slot.
-  Do not use irregular shaped DVDs and DVDs with a scratch protection film or self-adhesive labels attached.
-  Recordable (DVD-R or DVD+R) discs may not function correctly.
-  Dual format, dual-sided discs (DVD Plus, CD-DVD format) are thicker than normal CDs and consequently playback cannot be guaranteed, and jamming may occur.

It is recommended that only high quality 12 cm (4.7 in.) circular discs are used.

To locate the DVD load slot and the eject button, see **119, AUDIO/VIDEO CONTROLS**.

VIDEO MEDIA INHIBIT WITH VEHICLE MOVING

When the vehicle is moving the video picture will automatically be inhibited. The touch screen will display the **TV/My video** screen and the relevant safety message will be displayed.

Rear seat entertainment

CONTROLS (FRONT TOUCH SCREEN)

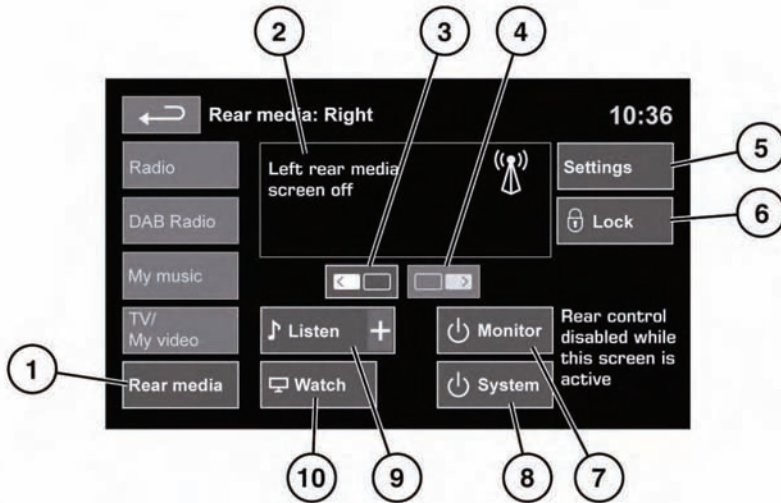

E135927

1. Select rear media.
2. Current rear media display.
3. Left screen select.
4. Right screen select.
5. Settings screen.
6. Remote control lock.
7. Turns off the selected screen.
8. Turns off the selected system.
9. Audio source select.
10. Video source select.

REAR MEDIA CONTROL FROM THE TOUCH SCREEN

When the main rear media control screen is displayed on the touch screen, the rear media remote control will be locked out. No part of the rear media system will operate until it is turned on via the touch screen.

REAR MEDIA SETTINGS

The rear media settings screen allows **Limousine Mode** and **TV Parental Control** to be turned on or off.

When **Limousine Mode** is selected, the rear passengers can control the total cabin audio system via the remote control.

TV Parental Control allows an age limit threshold to be set. If the content of a TV programme is unsuitable, a message is sent to the rear screen.

Note: When TV Parental Control is off the age limit slider is hidden.

Note: TV Parental Control is not available in all markets.

REMOTE CONTROL

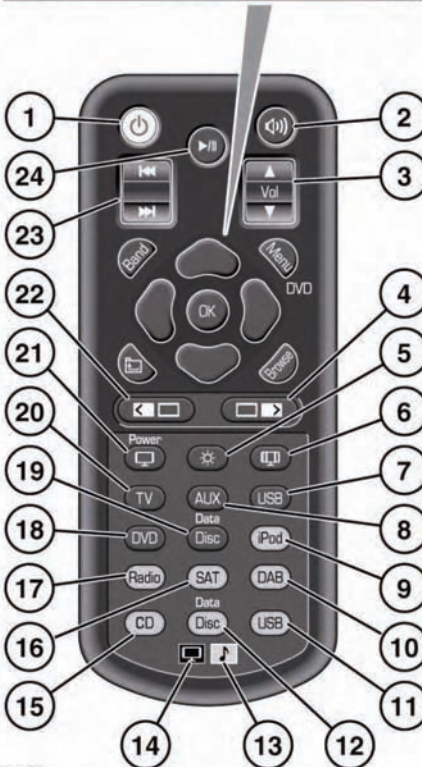
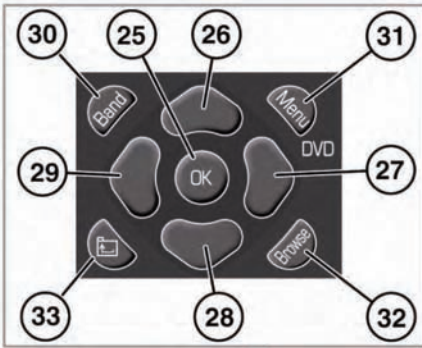

E136156

1. RSE on/off.
2. Cabin audio on/off (operates in Limousine mode only).
3. Cabin audio volume increase/decrease (operates in Limousine mode only).
4. Right user system select.
5. Screen brightness control: Select from day, night and auto.
6. Video screen format/zoom.
7. Rear USB socket select (video).
8. AUX socket input select (video).
9. iPod input select.
10. DAB radio select (market dependant).
11. Rear USB socket select (audio).
12. Data disc select (audio).
13. Indicates colour of buttons with audio function.
14. Indicates colour of buttons with video function.
15. CD select.
16. SAT radio select (market dependant).
17. Radio select.
18. DVD select.
19. Data disc select (video).
20. TV select.
21. Screen on/off.
22. Left user system select.
23. Seek forward and backwards for selected source and next/previous chapter for DVD.
24. Play/Pause for all non-live media (USB/ iPod/ CD/ DVD/ Data Disc).
25. Press to select highlighted station/channel.
26. TV presets list: First press displays list, further presses navigate up list.

Rear seat entertainment

27. TV channel list: First press displays list, further presses navigate forwards through list.
28. TV presets list: First press displays list, further presses navigate backwards through list.
29. TV channel list: First press displays list, further presses navigate down list.
30. TV/Radio band selection.
31. DVD menu display.
32. Browse: Select to view contents of connected device or CD.
33. Open next folder up.

USING RSE

Note: On new remote controls, a plastic strip isolates the battery from the electrical contacts. Before you use the remote control for the first time, pull out and discard the plastic strip.

Once rear seat entertainment has been selected on the touch screen, it can be operated with the remote control. To ensure the system responds to your selections, the upper end of the remote control should be pointed towards the applicable screen in the back of the front head restraint.

To activate the system, press the RSE on/off button (1), followed by the applicable user system button (4 or 22) and then the required audio or video function button. Subsequent selections on the remote control will operate the last selected user system. To avoid accidental operation of the wrong user system, it is advisable to always select the required user system before making any other selection.

HEADPHONES

The volume control for each set of headphones is adjusted on the headphones.

Press the channel selector button to cycle through available channels. Select the channel appropriate for the required screen.

Note: These headphones are not intended for use by the driver or outside the vehicle.

Note: The earpiece exteriors must remain exposed to the infra red transmitter in the overhead console. Any barrier will prevent them from working correctly.

When not in use, the headphones should be turned off.

REMOTE CONTROL BATTERY

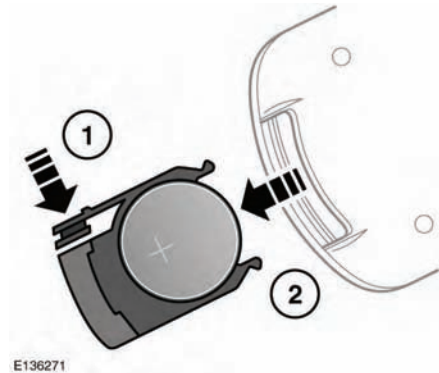

To renew the battery:

1. Press the locking catch inwards.
2. Pull out the battery cradle.

Install a new CR2025 type battery (available from your Dealer/Authorised Repairer), with the positive (+) side positioned as shown.



Avoid touching the new battery, as moisture/oil from fingers can reduce battery life and corrode the contacts.

Push in the battery cradle and ensure the locking catch is engaged.



Battery disposal: Used batteries must be disposed of correctly, as they contain harmful substances. Seek advice on disposal from your Dealer/Authorised Repairer or local authority.

USING VOICE CONTROL

Note:

The voice system has been designed to recognise a number of languages. However, Land Rover cannot guarantee the system will be compatible with every accent group within those languages. Please speak to your Dealer/Authorised Repairer about testing the Voice System for compatibility with a particular accent group.

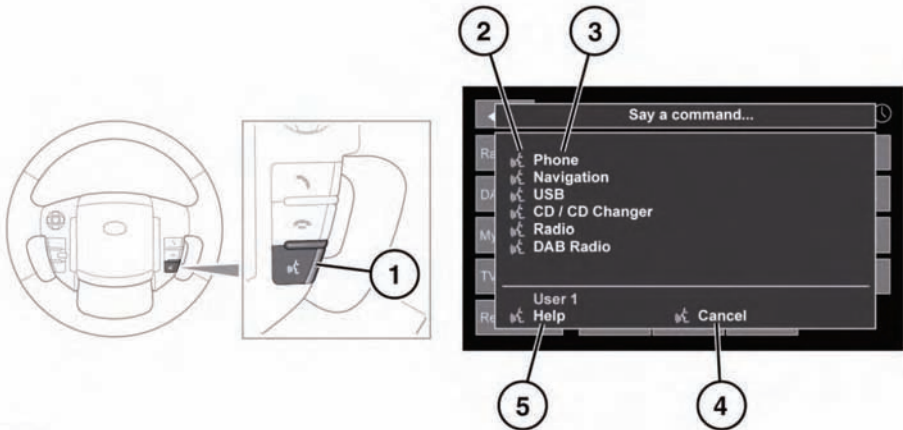

E134803

1. Voice button: Press briefly to start a voice session. A pop up will appear on the touch screen. Press and hold to cancel a voice session.

Note: Briefly press the Voice button during a voice session, to interrupt audible feedback. Wait for the tone to sound before giving the next command.

2. Voice symbol: Indicates that a command is available. Wait for the symbol to appear and a tone to sound before using the command.
3. Command list: Appears on the pop up panel, providing feedback and available commands at each stage of the voice session. Say an available command.

Note: As the commands are listed before the system is ready to listen, it is important to wait for the voice symbol to appear alongside the relevant command, before using the command.

4. When displayed, say **Cancel** to cancel the current voice session.
5. When displayed, say **Help** to get assistance during a voice session.

Note: The currently selected user (User 1 or User 2) is identified at the bottom of the command list.

Note: If a listed item is longer than the available space on the menu, ...> will appear. Use the seek controls on the steering wheel to view the entire entry.

VOICE TUTORIAL

To listen to a tutorial detailing the operation of the Voice system:

1. Briefly press the Voice button to start a voice session.
2. Wait for the tone to sound, then say **Voice tutorial**.

Alternatively, the tutorial can be selected using the touch screen, as follows.

1. Select **Setup** from the touch screen Home menu.
2. Select **Voice** from the Setup menu.
3. Select **Operating guide** from the Voice settings menu.
4. Select **Voice tutorial**.

The voice tutorial can be cancelled at any time by touching the on-screen pop-up or by pressing and holding the Voice button.

VOICE TRAINING

This is a feature designed to enable the system to better recognise the vocal characteristics of a user, once the training has been completed. To carry out Voice training:

1. Select **Setup** from the Home menu.
2. Select **Voice** and from the Setup menu.
3. Select **Voice training** from the Voice settings menu.
4. Select **User 1** or **User 2**, to start the training.
5. Follow the on-screen and audible instructions.

The training session can be cancelled at any time by touching the on-screen pop-up or by pressing and holding the Voice button.

VOICETAGS

Voicetags enable the user to personalise the Voice system so that a single name can be used to call-up a navigation destination, telephone number or radio channel.

To add a Voicetag:

1. Briefly press the Voice button to start a Voice session.
2. Wait for the tone to sound then say **Phone, Navigation** or **Radio**.
3. Say **Store voicetag**.

Alternatively, Voicetags can be managed via the touch screen as follows:

1. Select **Setup** from the Home menu.
2. Select **Voice** from the Setup menu.
3. Select **Voicetags** from the Voice settings menu.
4. Select the system which the Voicetag is to activate (**Phone, Navigation** or **Radio**).

Follow the on-screen and audible instructions.

NAVIGATION POI VOICE COMMANDS

To request the display of POI (Point Of Interest) identifiers on the navigation display:

Say **Navigation**, followed by the name of the desired POI category from the following list:

- Petrol station/Petrol.
- Parking/Car park.
- Land Rover Dealer.
- Hospital.
- Golf course.
- Tourist information.
- Restaurant/I'm hungry.
- Shopping centre.
- Hotel.
- Motorway service.
- Town centre.

Voice control

Icons will appear on the navigation display, indicating the locations of the selected POI. For further information about POIs, see **160, CATEGORIES AND SUB-CATEGORIES**.

TELEPHONE SYSTEM OVERVIEW

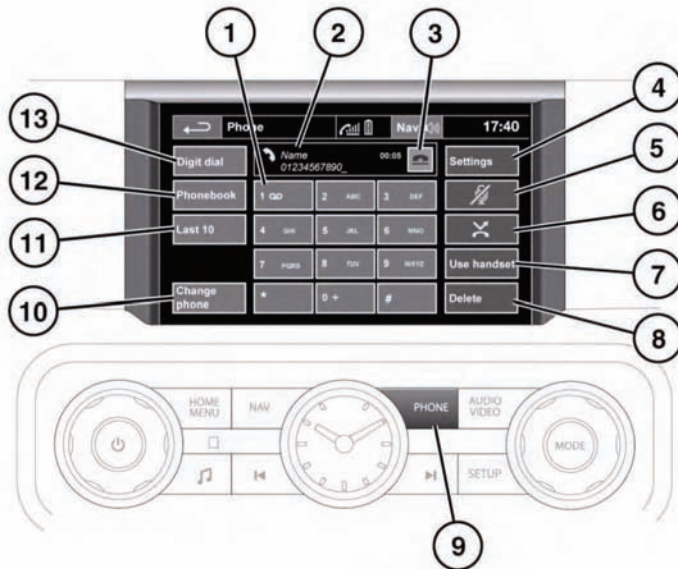

E135925

1. Touch and hold to retrieve your Voice mail.
 2. Status display. Displays the name and/or number dialed and call duration.
 3. Call Connect/Disconnect icons. Touch to send/accept or end/reject a call.
 4. **Settings:** Touch to access Voice mail, Answer options and Phone options.
 5. Mute microphone: Touch to initiate Privacy mode. While selected, the caller will not hear you talking.
 6. Auto reject: Touch to activate/deactivate. When active, any incoming calls will be rejected or diverted to voice mail (depending on mobile phone settings).
 7. **Use handset:** Touch to switch the call to your mobile phone.
 8. **Delete:** Touch and release to delete the last entered digit. Touch and hold to delete the whole entered number.
 9. **PHONE:** Press for shortcut to the touch screen Phone menu (applicable to Bluetooth® phones only).
 10. **Change phone:** Touch to search for a new phone or change to another paired phone.
 11. **Last 10:** Touch to access the last 10 dialed, received and missed calls.
 12. **Phonebook:** Touch to access the downloaded phonebook.
 13. **Digit Dial:** Touch to access Digit Dial mode.
- Note:** When a call is incoming, outgoing or active, the name or number is also displayed in the message centre.

Microphone location

The microphone for Telephone and Voice control is located behind a grille in the overhead console and directed towards the driver's seat. The microphone may not detect the voice of someone sitting in a passenger seat.

To optimise microphone performance, make sure the fascia air vents are not directed at the overhead console and that the heating and ventilation blower is not running at high speed.

BLUETOOTH® INFORMATION



Bluetooth® is the name for short-range radio frequency (RF) technology that allows electronic devices to communicate wirelessly with each other.

The Land Rover Bluetooth® system supports Bluetooth® Hands-Free Profile (HFP), Advanced Audio Distribution Profile (A2DP) and Audio Video Remote Control Profile (AVRCP).

Note: *HFP and A2DP/AVRCP profiles can be connected independently, so a phone can be connected via one, while a media device can be connected via the other, at the same time.*

Before making use of the vehicle's Bluetooth® phone system, your Bluetooth® phone must be paired and connected to the vehicle system. This is done using one of two methods; via your phone to the vehicle or from the touch screen to your phone. If one of these methods is not successful, try the other option.

Each time the ignition is switched on the system will attempt to connect with the last connected phone.

As mobile phones have a wide range of audio and echo characteristics, it may take a few seconds for the vehicle system to adapt and deliver optimum audio performance. To achieve this, it may be necessary to reduce the in-vehicle volume and ventilation fan speed slightly.

TELEPHONE SAFETY



Switch off your telephone in areas with a high explosion risk. This includes filling stations, fuel storage areas or chemical factories, as well as places where the air contains fuel vapour, chemicals or metal dust.



Always stow your mobile phone securely.



The functioning of cardiac pacemakers or hearing aids may be impaired when the phone is in use. Check with a doctor or manufacturer whether any such devices you or your passengers are using, are sufficiently protected against high-frequency energy.

The Health Industry Manufacturers' Association recommends that a minimum separation of 15 centimetres (six inches) is maintained between a wireless phone antenna and a pacemaker, to avoid potential interference with the pacemaker. These recommendations are consistent with the independent research by, and recommendations of, Wireless Technology Research.

TELEPHONE COMPATIBILITY

Please refer to the Ownership section of the Land Rover website at www.landrover.com, for a list of compatible phones.

Note: The Bluetooth® equipped phones listed on landrover.com have been tested for compatibility with Land Rover vehicles. Performance will vary, based on the phone's software version, battery condition, coverage and your network provider. Phones are warranted by their manufacturer, not Land Rover.

If the mobile phone supports Bluetooth® Hands Free Profile 1.5 (HFP 1.5), additional features will be displayed on the vehicle touch screen, such as battery meter, signal strength and network operator.

PAIRING AND CONNECTING USING THE MOBILE PHONE

Note: The process of pairing and connecting your phone with the vehicle using the mobile phone will vary depending on the type of mobile phone used.

1. Switch the ignition on and ensure that the touch screen is active.
2. From the home menu, select **Phone**.
3. If no phone is connected, select **Search new**. Otherwise select **Change phone** and then **Search new**.
4. Select **Device to vehicle** option.

Note: The vehicle's Bluetooth® system is discoverable for only 3 minutes.

5. Using the mobile phone, search for Bluetooth® devices.
On some phones, this is referred to as new paired device. See your phone's operating instructions for further information.
6. When the vehicle's Bluetooth® system is discovered, begin the pairing process using your mobile phone and follow any directions shown on the touch screen. Select **Yes** when prompted, to confirm the pairing.

The phone and then the vehicle system will ask for a PIN (Personal Identification Number). Each time you are prompted, enter the PIN (Personal Identification Number) of your choice and select **OK** to confirm.

7. Once your phone is paired and connected to the system, a confirmation message will be displayed before switching to the Digit Dial screen.

Note: Some mobile phones require the Bluetooth® pairing to be set as 'authorised' or 'trusted' in order to automatically connect. Please refer to your phone's operating instructions for further information.

PAIRING AND CONNECTING USING THE TOUCH SCREEN

1. Switch on your mobile phone's Bluetooth® connection. Make sure that your mobile phone is in Bluetooth® discoverable mode, sometimes referred to as find me mode (see your phone's operating instructions for more information).
2. Switch the ignition on and ensure the touch screen is active.
3. From the home menu select **Phone**.
4. If no phone is connected, select **Search new**. Otherwise select **Change phone** and then **Search new**.
5. Select **Vehicle to device** option.

Note: If more than 4 phones are detected, it may be necessary to use the scroll bar to see the entire list.

Note: If more than 4 phones are detected, it may be necessary to use the scroll bar to see the entire list.

6. Identify your phone from the displayed list and select the corresponding **Pair and connect** option.
7. When prompted, enter the PIN code into your phone. See your phone's operating instructions for more information.
8. Once your phone is paired and connected to the system, a confirmation message will be displayed before switching to the Digit Dial screen.

Note: Due to the duration of a Bluetooth® search, it is advised that the timeout to home screen feature is switched off before attempting to search for Bluetooth® devices. See **116, SCREEN SETTINGS**.

CHANGING THE CONNECTED PHONE

Up to 10 mobile phones can be paired with the vehicle in the same way. However, only one can be connected and ready for use as a phone at any one time.

To connect a different paired phone to the vehicle, follow the steps below:

1. From the home menu, select **Phone**.
2. A menu will appear. Select **Change phone**.
3. Identify and select your phone from the displayed list.
4. Once your phone is connected to the system, a confirmation message will be displayed before switching to the Digit Dial screen.

TELEPHONE SYSTEM ICONS



Connect. Use to send or accept a call and access last 10 calls list.



Disconnect. Use to end or reject a call.



No phone connected.



Phone signal strength indicator.



Phone battery level indicator.



Bluetooth. Indicates that a Bluetooth® device is connected.



Tick. Indicates that a Bluetooth® device is paired.



Voicemail. Press and hold to dial the stored voicemail number.



Scroll bar up arrow. Use to scroll up lists of detected phones, calls or phonebook entries.



Scroll bar down arrow. Use to scroll down lists of detected phones, calls or phonebook entries.

STEERING WHEEL CONTROLS

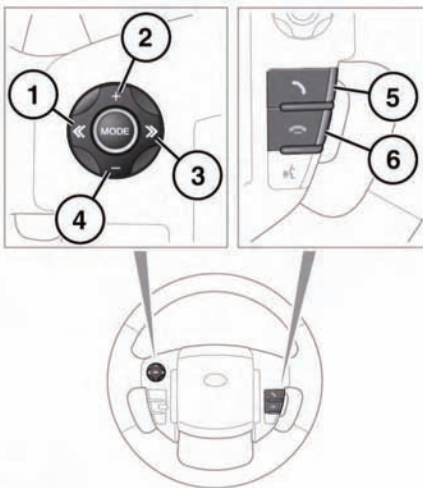

E135928

1. Press to scroll up a displayed list.
2. Press to increase volume when in a call.
3. Press to scroll down a displayed list.
4. Press to decrease volume when in a call.
5. Press and release to access last 10 dialed list or dial a number/contact. Press and hold to access phonebook list view.
6. Press to end a call or to reject an incoming call.

Note: When scrolling through a phonebook or last 10 list, each contact is also displayed in the message centre.

CALL VOLUME

The phone call volume is operated by the audio system's volume control.

If the audio system is in use when a phone call is active, the audio system source is suppressed for the duration of the call.

DIALLING

Once your phone is connected to the vehicle's system, Digit Dial is the default screen in Phone mode.

Using the on-screen keypad, enter the required number and touch the connect icon to send.

Note: When entering a number, you can change the phone number shown on the touch screen using the **Delete** button. A momentary touch erases a single digit, a long touch erases the complete number.

PHONEBOOK

Contacts stored in the memory of a paired phone can be automatically downloaded to the vehicle's phonebook each time the phone is connected to the system. See **148**, **TELEPHONE COMPATIBILITY**.

Certain mobile phones store the phonebook in two different areas, the SIM card and the phone memory. The vehicle system will access only those numbers stored in the phone memory.

To access contacts from the phonebook:

1. From the Phone menu, select **Phonebook**.
2. Using the alpha keys, type the name of the contact you want to search for. Repeated selections of the same key scrolls through the letters displayed on the keys.
3. If the desired contact is shown in the view, they can be dialled by pressing the connect button. Alternatively, select **List** to access the phonebook list view.
4. In the Phonebook list view, touch to call. If a contact has more than one number stored, touch to access the additional numbers.

Note: It may be necessary to use the scroll bar to see the entire list.

Telephone

There are also options to view more contact information, by selecting the corresponding i key.

If your phone supports contact type data, you will be able to see a contact type icon in the vehicle's phonebook directory. These can be seen on the right-hand side of each contact in the directory and will indicate one of the following types:



Default.



Mobile.



Home.



Work.

LAST 10 OPTION

Allows view of the last 10 calls made, received or missed.

***Note:** The vehicle will display the list in the order the calls were recorded. If this information is not available, they will be displayed as they are sent from the mobile phone. Some phones may arrange the list in reverse or other order.*

SETTINGS

Depending on vehicle specification, there are up to 3 options in the **Settings** menu:

- The **Voice mail** option allows you to save or edit the number of the voice mail server for your specified network provider.
- The **Answer options** allows you to enable/disable the Auto answer feature and, if Voice control is fitted, the Caller announce feature.

***Note:** With the Caller announce feature turned on and a compatible Bluetooth® phone connected, the voice control system will announce the incoming caller's name if stored in the vehicle phonebook. See **148**, **TELEPHONE COMPATIBILITY**.*

- The **Phone options** allow you to set your desired ring tone either to the preset car ring tone, or to the handset ring tone. The Phone options also gives you access to the Phonebook options. See **151**, **PHONEBOOK**.

THE NAVIGATION SYSTEM

Navigation instruction is by map and turn information displayed on the touch screen and can be complemented by voice guidance if required. A detailed intersection map is also displayed in the instrument panel. The system uses signals from Global Positioning System (GPS) satellites combined with information from vehicle sensors and from data stored on the hard drive, to establish the true vehicle position.

Note: Mapping data loaded on the hard drive is relevant to the market in which the vehicle is first sold and will provide guidance and information only for that area. Your local Dealer will have details of software updates.

Using this combination of data sources the vehicle navigation computer enables you to plan and follow a route map to your desired destination.

The touch screen is used to control navigation via menus, text screens and map displays.

USING THE NAVIGATION SYSTEM

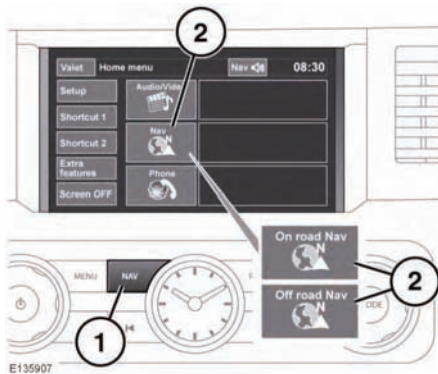

1. **NAV** shortcut button.
2. **NAV** soft key.

Note: On vehicles with off-road navigation, the soft key includes **On road** or **Off road**, to show the current Navigation mode.

From the Home menu, touch the **NAV** soft key. Alternatively, press the **NAV** shortcut button on the fascia. A caution screen will be displayed.

If the navigation screen language has not been set, now is the time to set it. Select **Language**, make a selection and confirm it by touching the **OK** soft key. You will be returned to the **CAUTION** screen.

After touching the **Agree** soft key, the touch screen will display the **Nav menu** (which is the navigation system Main menu and covered over two screens) or the screen that was in use when you last switched off the system.

Note: After approximately 12 seconds, the menu soft keys will disappear and display the map information only. This will show current vehicle position. Touch the **Nav menu** soft key to display the Main menu screen.

At this point, the first time user should set up personal preferences in the **Nav set-up** area. These settings are applied whenever navigation is used.

MAIN MENU

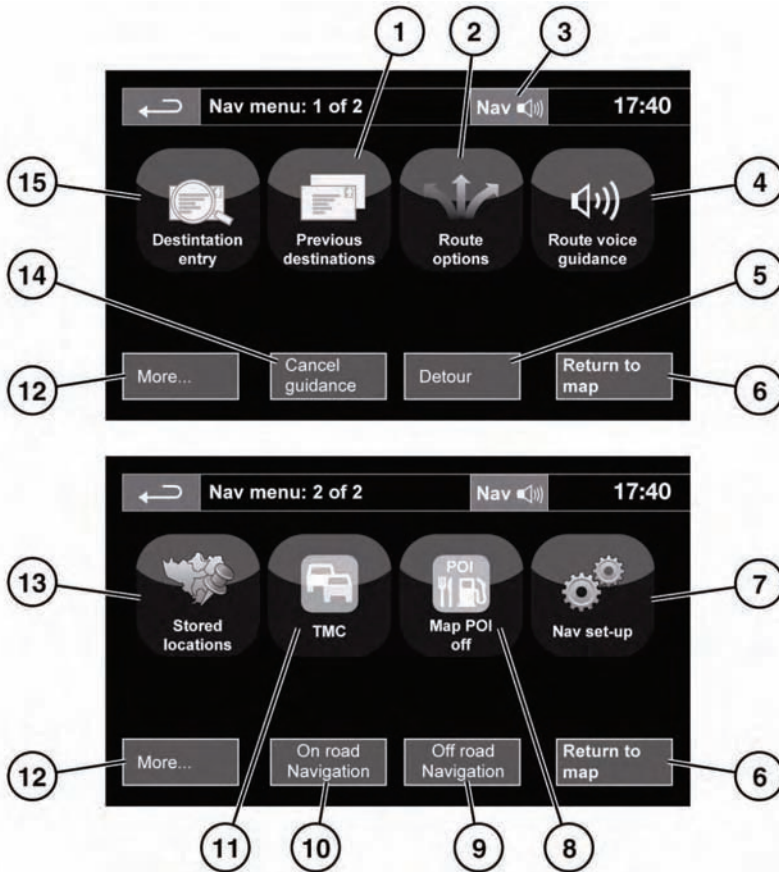

E135923

- 1. Previous destinations:** Displays previous destinations entered.
- 2. Route options:** Allows selection of various options for the route.
- 3.** When a destination is set, the Range Rover logo is replaced by a soft key which enables the last voice instruction to be repeated.
- 4. Route voice guidance:** Allows the voice guidance messages to be turned off for the current journey. The soft key is highlighted while voice guidance is enabled.
- 5. Detour:** Allows a detour from the current route.
- 6. Return to map:** Advances to the main map screen.
- 7. Nav set-up:** Settings for the navigation system.

8. **Map POI off:** Turns the POI (Point Of Interest) icons on the map on/off.
9. **Off road Navigation:** Changes the system to Off road navigation mode.
10. **On road Navigation:** Changes the system to On road navigation mode.
11. **TMC (Traffic Message Channel):** Not used for entering a destination but, when enabled, will provide data about road conditions and any events that may affect the journey.
12. **More...:** Displays the other Nav menu screen.
13. **Stored locations:** Manages the stored locations.
14. **Stop guidance:** Cancels current route guidance.
15. **Destination entry:** Provides a choice of options for entering a destination.

MAP SPLIT SCREEN

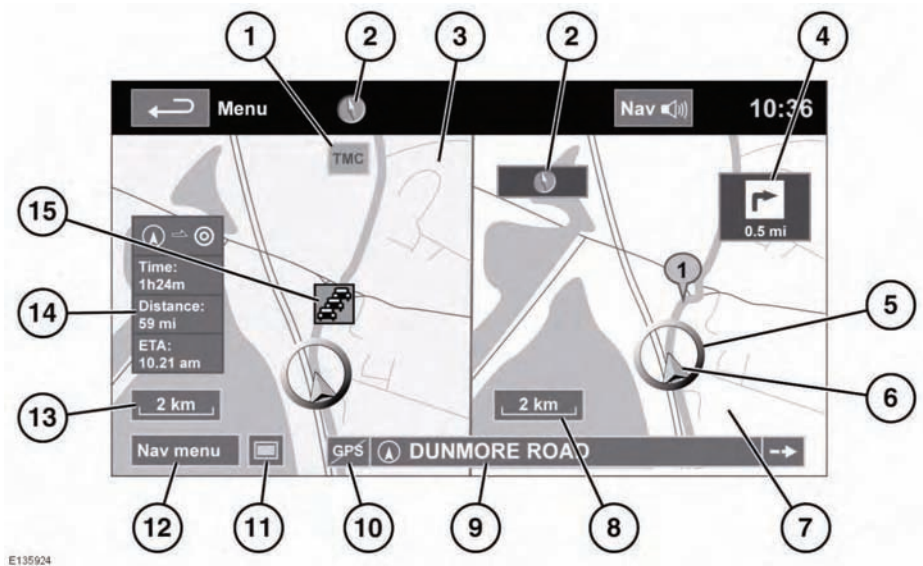





E135924

1. TMC (Traffic Message Channel) information.
2. Small compass display which always indicates North.
3. Normal screen.
4. Next direction display.
5. Current vehicle position.
6. Vehicle direction arrow.
7. Split screen.
8. Split screen scale/zoom setting.
9. Current street location.
10. No GPS signal.
11. Screen mode selection.
12. Nav menu: Touch to select the Navigation menu screen.
13. Normal screen scale/zoom setting.
14. Distance/time to destination.
15. TMC event (traffic congestion).

SCREEN MODES

Touch the screen mode selection button to view a series of icons, each depicting a different screen mode (as detailed below). Touch the relevant icon to select the desired screen mode.

-  Full screen view.
-  Split screen view. A more detailed view of the local area and road system is displayed on the right.
-  Shows the next junction in the right half screen.
-  This view is only available when travelling on a motorway. It displays automatically to show remaining exits along your route.



Shows list of forthcoming junctions and turn directions on the right half screen.

SEARCH AREA

The navigation map database is divided into countries, or areas of countries, called search areas. When setting a route, the destination (or waypoint) entered must be in the currently selected search area.

Before attempting to set a destination or waypoint, set the correct search area as follows:

1. Select **Destination entry** from the main navigation menu.
2. Select page 2 of **Destination entry** then select **Search area**.
3. Scroll through the list and select the 3 letter code that corresponds to the desired destination area.
4. Select **OK**. The destination entry menu is shown and the information window shows the currently selected search area.

SETTING A DESTINATION

After touching **Agree**, the initial map screen is displayed, now select **Nav Menu**.

From the Navigation Menu, select **Destination entry**.

Select **Address** from the **Destination** screen and input the town name.

Once sufficient letters have been entered, touch **List** to display all the possible towns.

If necessary, use the scroll arrows to the left of the list to search up or down. Select the town you require.

Now enter the road name. Once sufficient letters have been entered, touch **List** to display all the possible roads.

Select the road you require.

Enter the house number of the address (if known) then touch **OK** to confirm.

If the house number is not known, press **OK** - the mid-point of the road is then used as the destination.

The map screen showing the route settings and destination details is displayed.

START GUIDANCE

After touching **Destination**, the system will calculate the route.

There is now a choice to select **3 Routes**, **Change route** or to **Start** navigation guidance.

Touch **3 Routes** to display a choice of three different route options on the map.

The roads on the map are drawn in three different colours to highlight each route. EcoRoute helps you find the most fuel efficient route available. A display of three leaves indicates the most fuel efficient route.

Select route **1**, **2** or **3** by touching the respective box displayed on the right side of the map.

Touch **Change Route** followed by **Route prefs.** to change the route settings. If a destination is already set, touch **Waypoint** to add a waypoint in the journey if required.

When you have made your selection, if any, touch **Go**.

***Note:** As you approach a junction, in addition to the voice guidance, an inset on the map will display an enlarged view of the junction.*

***Note:** The next turn on the route is displayed in the message centre.*

EASY ROUTE

In **Route options**, **Easy Route** can be turned **On** or **Off**.

When **On** is selected, **Easy Route** changes the calculation parameters of **Route 3** in order to reduce:

- Junctions.
- Turns.
- Turns that cross traffic.
- The priority of minor roads.
- Complex junctions and manoeuvres.

LEARN ROUTE

In **Route options**, **Learn Route** can be turned **On** or **Off**.

When **On** is selected, if you make the same deviation from the proposed route three times, then the system will memorize the deviation and offer that as the normal route from then on. Select **Reset all routes** to delete any learnt routes and return to the default settings.

OFF-ROAD NAVIGATION

The system can be switched between On-road and Off-road navigation by pressing the fascia **NAV** button twice, from anywhere in the system, then selecting **On-road** or **Off-road** as required. Alternatively, Off-road navigation can be selected from page 2 of the Main menu.

When Off-road navigation is enabled, the **Nav** soft key on the Touch screen Home menu displays **Off-road navi**.

Off-road navigation maps are similar to the on-road maps but have additional features and information, such as a large compass display, heading, altitude, latitude and longitude etc.

When switching to off-road navigation mode during on-road guidance, the current highlighted route will be removed from the map and on-road guidance will be suspended.

Way points and destination icons will remain displayed. The destination is marked with a double circle.

When exiting off-road guidance, the system recalculates the route and reverts to on-road guidance.

Note: *TMC is not available in off-road navigation mode.*

VOICE GUIDANCE

To turn voice guidance on or off but maintain route guidance, proceed as follows:

1. Touch **Nav menu** on the map menu screen.
2. Touch the **Route voice guidance** soft key. The soft key will be highlighted when voice guidance messages are enabled.

CANCEL ROUTE GUIDANCE

To stop route guidance, proceed as follows:

1. Touch **Nav menu** on the map menu screen.
2. Touch the **Stop guidance** soft key.

QUICK POI SELECTION

Touch the Map screen to display the POI button. Touch the **POI** (Point of interest) button. The screen shows six suggested categories, five of which can be selected as quick points of interest.

Note: *The POI icons will not be shown if the map zoom level is greater than 1 km (½ mile).*

Select a Quick POI category, or select **More** to see further POIs. Touch **OK** to confirm a selection.

The map screen with the POI icon(s) is displayed. Select the five POIs you wish to see when the Quick POIs are displayed.

RESTORE SYSTEM DEFAULTS

If you have made any changes to the system's default settings, use this menu to restore the original settings.

MEMORY POINTS

From the navigation menu, select **Stored locations**. This enables you to manage destinations such as, place of work, home, favourite restaurant or areas to avoid.

From the **Stored locations** menu you can save up to 400 memory points or add your home address.

Select **Memory Points** to add a stored location.

Touching any of the **Stored locations** submenus allows you to **Add**, **Edit** or **Delete**.

Select **Add** to store a memory point.

MEMORY POINT DETAILS

Touch **Info**. to display the details of the selected memory point.

The details include Icon, Name, Position and Tel.

The telephone number can be called by touching the telephone button if a telephone is connected.

The memory point details can be edited from the **Stored locations** screen.

POSTCODE

Not all countries have this facility. Enter the postcode of your waypoint or destination from the keypad. The postcode must be entered precisely, including any spaces or punctuation.

When the postcode has been entered touch **OK**.

EMERGENCY

Not all countries have this facility. Touch **Emergency** on the **Destination entry** screen to display a list of local police stations, hospitals or Land Rover Dealerships.

Press **Name** to display the list in alphabetical order or **Distance** to display the list in order of proximity to the current vehicle location.

Touch the name of the facility to set it as a destination or waypoint.

MAP

After selecting map, the local area map is displayed. Drag the circle to the area for your destination or waypoint, zooming in if required.

This location can be stored as a destination or waypoint.

COORDINATES

If you know the coordinates of your destination they can be entered from this screen. The full latitude must be entered first before the longitude coordinates can be entered.

When the coordinates have been entered, touch **OK**.

If the coordinates entered are not contained within the area covered by the available maps, a message will be shown. This can also occur if the incorrect coordinates have been entered.

RECALLING A PREVIOUS DESTINATION

After selecting **Previous destinations** from the menu, the screen shows a list of stored previous destinations. Select your destination by touching the bar. The details will be displayed for confirmation.

Note: In some markets, list scrolling is not active whilst driving for legislative reasons. Only the items shown at the top of the list can be selected.

MOTORWAY

After selecting **Motorway** from the menu, enter the road name or number, then select an entrance or exit. All of the entrance or exit junctions for the chosen road are displayed.

The map showing the selected motorway and the selected exit junction is displayed.

The destination has now been set and the route is calculated.

POINTS OF INTEREST (POI)

After selecting **Points of interest** from the menu, touch **Name** to input the POI name, for example, **Petrol** to display fuel stations on the map, or touch **List** for a list of POIs.

Alternatively, choose **Category** to see all categories of POI and make your selection.

Use the scroll arrows to change pages.

Some POIs are sub-categorised, e.g. selecting **Community** will be further divided into:

- Community Centre.
- Exhibition Centre.
- Hospital.
- Park & Recreation.
- Town Hall

Note: If entering a POI name results in too many matches being listed, try entering the town name first. If you do not know the name of the POI you want, try selecting a POI category.

Note: POI icons can only be displayed up to the 1 km (½ mile) zoom level.

Once the POI has been selected the route is determined. Touch **Change route** to change the route settings, or touch **OK** to start the route calculation.

DEALER LOCATIONS

Details of Land Rover Dealers are held on the Navigation System hard drive as a points of interest (POI) category. Certain Dealers may be located in areas that are not fully mapped on the hard drive. If a route is set to one of these Dealers, guidance may only be possible to the nearest town centre; in this case a warning message will be displayed.

Note: If Land Rover Dealers (or certain other categories, such as airports) are selected, they will be displayed across all search areas.

ENTRY BY TOWN

If a town name is entered first, the points of interest listed will be restricted to that town.

1. From the Input POI Name screen, touch **Town**.
2. Enter the town name required.
3. Touch **List** to display the list of possible towns.
4. Select the town required.
The Input POI screen is displayed again.
5. Enter the POI name required.

CATEGORIES AND SUB-CATEGORIES

The POI database is divided into a number of categories. Each main category is further divided into a number of sub-categories.

The first entry in the list of Restaurant sub-categories, is **ALL**. This selects all of the Restaurant sub-categories.

To narrow the search, touch the **Town** button. This will display the alpha keyboard to allow the desired town name to be entered.

LIST SOFT KEY

The **List** button can be used when the characters entered reduce the possible entries to a small enough number.

You can also select **List** (when active) without entering a POI name. All the relevant points of interest will be displayed, e.g. in a selected town or category.

ALL SOFTKEY

The **All** button shows a list of all POI categories.

LOCAL POI SEARCH

This selects the points of interest in all categories within 32 kilometres (20 miles) of the vehicle.

- Touch the **All Local POIs** button.

RDS-TMC OVERVIEW

Radio Data System-Traffic Message Channel (RDS-TMC) is a feature that announces traffic hold-ups on your route as broadcast by radio stations that transmit TMC information.

Touch the **TMC** button on the Navigation Menu to access the TMC menu.

TMC events ahead on route can be displayed by touching the **Events ahead** soft key. TMC can be set to display on the map for all events, for major events or can be switched off. During route calculation, it can be set to avoid TMC events along the route.

RDS-TMC DISPLAY

When a TMC signal is received the icon in the top left of the screen will appear green. If a TMC signal is not being received, the icon will be shown with a bar through it.

The system will inform the driver of any reported roadworks, narrow road, contraflow, accidents, slippery road, diversion, information, parking information, congestion or other hazard.

The driver is informed of a traffic event as follows:

- A TMC Event icon shown on the map at the location of the event.
- Text can be displayed showing the details of each occurrence which can be selected either by touching the screen icon or from the traffic information list.
- Dynamic route guidance, which calculates an alternative route when the system receives the traffic event warning affecting the route currently set in the navigation system.
- Traffic event list shows all events sorted by road name/ distance on your selected route in a straight line or along your actual route.

The information regarding the hold-up is maintained and updated even if the vehicle crosses into another country.

RDS-TMC ICONS

Any traffic event (broadcast on TMC) in your area, will be displayed as a warning icon on the map and an alert may be displayed as a message giving the road number(s) and between which junctions the hold-up or event occurs.

This data is stored in the system for up to 30 minutes.









The colour of the TMC icon changes in order to show the type and priority of a TMC event. The background colour of the icon returns to normal when there is no longer an event or hold-up, or if any re-route instructions are calculated.

Navigation system

The TMC Event icons appear on the navigation map display to indicate the location and nature of a TMC event.

TMC Event icons will appear on the map, even if the event does not occur on your route.

LEVEL 1 TMC EVENT ICONS

| | |
|---|--|
|  | Incident (Red star) |
|  | Moving Tailback Ahead (Red arrow) |
|  | Moving Tailback Both Carriageways (Red double arrow) |
|  | Slow Traffic Ahead (Yellow arrow) |
|  | Slow Traffic Both Carriageways (Yellow double arrow) |
|  | Information (Yellow circle) |
|  | Incident (Yellow star) |
|  | Stationary Traffic Ahead (Red arrow pointing on line) |
|  | Stationary Traffic Both Carriageways (Red double arrow pointing on line) |

Note: Single arrow icons indicate that the traffic event affects traffic travelling in the direction of the arrow. Double arrows indicate that both directions are affected.

LEVEL 2 TMC EVENT ICONS

| | |
|---|----------------------------|
|  | Other Hazard (Yellow) |
|  | Roadworks (Pink) |
|  | Narrow Road (Pink) |
|  | Contraflow (Pink) |
|  | Accidents (Pink) |
|  | Slippery Road (Yellow) |
|  | Diversion (Yellow) |
|  | Parking Information (Grey) |
|  | Information (Grey) |
|  | Congestion (Red) |

USING TMC

Dynamic route guidance will calculate an alternative route to avoid a traffic event when the system receives an event warning. The system calculates a new route for all sections. However, if any way points are set, the system calculates for the next way point. If the event on route is serious (closed road) or if the new route is shorter than the current one and the current one was not recalculated within the last 5 minutes, then a message to confirm the new route will be displayed. This pop-up message will be displayed for 10 minutes and if the new route is not rejected, then the vehicle will follow the new route.

ORDNANCE SURVEY DATA

Please read this agreement carefully before using the Navigation System.

This is a licence agreement to use the Ordnance Survey (OS) Code-Point data incorporated in the Navigation System. By using this Code-Point data you accept and agree to all the terms and conditions below.

OWNERSHIP

The OS Code-Point data is licensed by Ordnance Survey with permission of Her Majesty's Stationery Office. © Crown Copyright. All rights reserved.

LICENCE GRANT

OS grants you a non-exclusive licence to use your copy of the OS Code-Point data for your personal use solely as part of the Navigation System. You may transfer the licence to a subsequent purchaser of the vehicle with which the Navigation System is supplied, provided that the purchaser agrees to abide by each of the terms of this licence.

LICENCE TERMS

These licence terms are governed by English Law and are subject to the exclusive jurisdiction of the English courts.

LIMITATIONS OF USE

The OS Code-Point data is restricted for use in the specific system for which it was created. Except to the extent explicitly permitted by mandatory applicable laws, you may not extract or re-utilise any part of the contents of the OS Code-Point data, not reproduce, copy, modify, adapt, translate, disassemble, decompile, or reverse engineer any portion of the OS Code-Point data.

LIMITATION OF LIABILITY

Ordnance Survey does not warrant or represent that any of the Code-Point data is accurate, error-free or suitable for your purposes. In no event shall OS or the supplier of the Navigation System using the OS Code-Point data be liable for any consequential, special, incidental or indirect damages for any direct or indirect loss of revenue, profits, business, data, or use, incurred by you or any third party arising out of your use of the OS Code-Point data, whether in an action in contract or tort (including negligence and breach of statutory duty) or otherwise, even if OS or the supplier of the Navigation System has been advised of the possibility of such damages. In any event, OS's liability for direct damages is limited to the price of the copy of the OS Code-Point data. Nothing in these licence terms shall operate to exclude or limit any liability which cannot be excluded or limited by law.

THE DISCLAIMER OF WARRANTY AND LIMITATION OF LIABILITY, SET FORTH IN THIS AGREEMENT, DO NOT AFFECT OR PREJUDICE YOUR STATUTORY RIGHTS WHERE YOU HAVE ACQUIRED THE DATABASE OTHERWISE THAN IN THE COURSE OF A BUSINESS.

NAVTEQ CORPORATION

Please read this agreement carefully before using the Navigation System.

This is a licence agreement for your copy of the Navigable Map Database, (the 'DATABASE') originally made by NAVTEQ Corporation), used in the Navigation System. By using this DATABASE you accept and agree to all the terms and conditions below.

TRANSFER

You may not transfer the DATABASE to third parties, except together with system for which it was created, provided that you do not retain any copy of the DATABASE, and provided that the transferee agrees to all terms and conditions of this agreement.

DISCLAIMER OF WARRANTY

NAVTEQ Corporation does not warrant or make any representations regarding, either express or implied, regarding the use or results of the use of the DATABASE in terms of its correctness, accuracy, reliability, or otherwise and expressly disclaims any implied warranties of quality, performance, merchantability, fitness for a particular purpose or non-infringement.

NAVTEQ Corporation does not warrant that the DATABASE is or will be error-free. No oral or written information or advice provided by NAVTEQ Corporation, your supplier or any other person shall create a warranty.

GOVERNMENT END USERS

If the DATABASE is for a region of North America and is being acquired by or on behalf of the United States government or any other entity seeking or applying rights similar to those customarily claimed by the United States government, the DATABASE is licensed with 'limited rights'.

Utilization of the DATABASE is subject to the restrictions specified in the 'Rights in Technical Data and Computer Database' clause at DFARS 252.227-7013, or the equivalent clause for non-defence agencies. Manufacturer of the DATABASE of North America is NAVTEQ Corporation, 10400 W. Higgins Road, Suite 400, Rosemont, Illinois 60018, USA.

EUROPEAN DECLARATION OF CONFORMITY



Hereby, DENSO CORPORATION declares that this DN-NS-019 is in compliance with the essential requirements and other relevant provisions of Directive 1999/5/EC.

TYRE REPAIR KIT

-  **If you are in any doubt regarding your ability to carry out the instructions, contact your Dealer/Approved Repairer before attempting the repair.**





Your vehicle may not be equipped with a spare tyre. If this is the case, your vehicle will be fitted with a Land Rover tyre repair kit which can be used to repair **one** tyre. It is essential that you read the following guide before attempting to repair a tyre.

The tyre repair kit seals most punctures with a maximum diameter of 6 mm (1/4 inch).

The tyre repair kit is located under a panel set in the loadspace floor (5 seat vehicles), or behind an access cover in the left side of the loadspace (5 seat vehicles).

Note: *The sealant used in the tyre repair kit has a shelf life and the expiry date is shown on the tyre sealant bottle. Ensure that the container is replaced before the expiry date.*

TYRE REPAIR KIT SAFETY INFORMATION

-  **Some tyre damage may only be partially sealed, or may not seal at all, depending on the amount and type of damage. Any loss of tyre pressure can seriously affect vehicle safety.**
-  **Do not use the tyre repair kit if the tyre has been damaged by driving while under-inflated.**
-  **Only use the tyre repair kit to seal damage located within the tyre tread area.**
-  **Do not exceed 80 km/h (50 mph) when a repaired tyre is fitted to the vehicle.**
-  **The maximum distance that should be driven when a repaired tyre is fitted, is 200 km (125 miles).**

-  **When a repaired tyre is fitted, drive with caution and avoid sudden braking or steering manoeuvres.**
-  **Only use the tyre repair kit for the vehicle with which it was supplied.**
-  **Do not use the tyre repair kit for any other purpose than tyre repair.**
-  **Never leave the tyre repair kit unattended when in use.**
-  **Only use the tyre repair kit within the -30 °C to +70 °C temperature range.**
-  **Always keep children and animals at a safe distance from the tyre repair kit when in use.**
-  **Do not stand directly beside the compressor when it is operating.**
-  **Check the tyre sidewall prior to inflation. If any cracks, damage or deformities are apparent, do not inflate the tyre.**
-  **Watch the tyre sidewall during inflation. If any cracks, bumps or similar damage, or deformities appear, switch off the compressor and deflate the tyre.**

Tyre repair kit

TYRE REPAIR KIT OVERVIEW

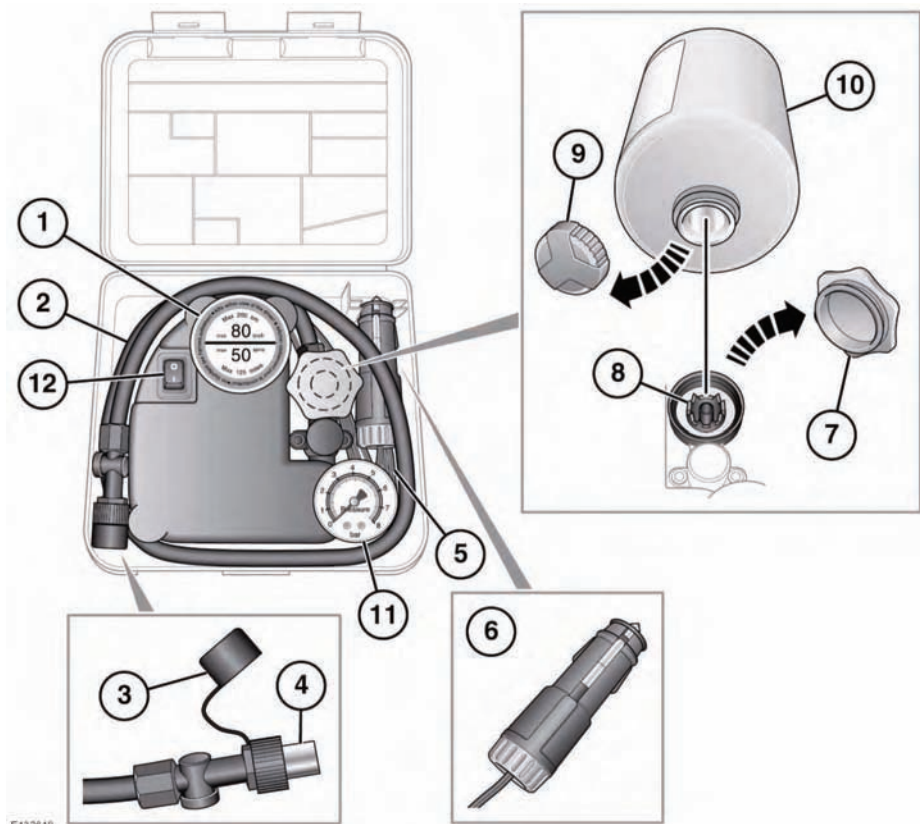

E132049

1. Maximum speed label. 80 km/h (50 mph).
2. Tyre inflation hose.
3. Inflation hose protective cap.
4. Inflation hose connector.
5. Compressor power cable.
6. Power cable connector.
7. Sealant bottle receiver cap (orange).
8. Sealant bottle receiver.
9. Sealant bottle cap.
10. Sealant bottle.
11. Tyre pressure gauge.
12. Compressor on/off switch (I = on. 0 = off.).

USING THE TYRE REPAIR KIT



Avoid skin contact with the sealant which contains natural rubber latex.



If the tyre inflation pressure does not reach 1.8 bar (26 psi, 180 kPa) within seven minutes, the tyre may have suffered excessive damage. A temporary repair will not be possible, and the vehicle should not be driven until the tyre has been replaced.



Before attempting a tyre repair, ensure that the vehicle is parked safely, as far away from passing traffic as possible.



Ensure that the parking brake is applied and **P** (Park) is selected.



Do not attempt to remove foreign objects such as nails, screws, etc. from the tyre.



Always run the engine when using the compressor, unless the vehicle is in an enclosed or poorly ventilated space, as this may cause asphyxiation.



To prevent overheating, do not operate the compressor continuously for longer than ten minutes.

Note: All vehicle drivers and occupants should be made aware that a temporary repair has been made to a tyre fitted to the vehicle. They should also be made aware of the special driving conditions imposed when using a repaired tyre.

REPAIR PROCEDURE



Check the tyre sidewall prior to inflation. If there are any cracks, bumps or similar damage, do not attempt to inflate the tyre. Do not stand directly beside the tyre while the compressor is pumping. Watch the tyre sidewall. If any cracks, bumps or similar damage appear, turn off the compressor and let the air out by means of the pressure relief valve. Do not continue to use the tyre.

1. Open the tyre repair kit and peel off the maximum speed label. Attach the label to the fascia in the driver's field of vision. Take care not to obstruct any of the instruments or warning lights.
2. Uncoil the compressor power cable and the inflation hose.
3. Unscrew the orange cap from the sealant bottle receiver and the sealant bottle cap.
4. Screw the sealant bottle into the receiver (clockwise) until tight.
 - Screwing the bottle onto the receiver will pierce the bottle's seal. Once the bottle has been fitted, a ratchet prevents it from being removed.
5. Remove the valve cap from the damaged tyre.
6. Remove the protective cap from the inflation hose and connect the inflation hose to the tyre valve. Ensure that the hose is screwed on firmly.
7. Ensure that the compressor switch is in the off (0) position.
8. Insert the power cable connector into the auxiliary power socket. See **65, STORAGE COMPARTMENTS**.
9. Unless the vehicle is in an enclosed area, start the engine.

10. Set the compressor switch to the on (I) position.
11. Inflate the tyre to a minimum of 1.9 bar (26 psi) and a maximum of 3.5 bar (51 psi).
 - When pumping the sealant through the tyre valve, the pressure may rise up to 6 bar (87 psi). The pressure will drop again after approximately 30 seconds.
12. During the inflation, switch the compressor off briefly, to check the tyre pressure using the gauge mounted on the compressor.
 - It should not take longer than seven minutes to inflate the tyre. If, after seven minutes, the tyre has not yet reached minimum pressure, the tyre should not be used.
13. Once the tyre has been inflated, switch off the compressor. If desired, the engine may be turned off after the compressor has been turned off.
14. Remove the power connector from the auxiliary power socket.
15. Remove the inflation hose from the tyre valve, by unscrewing it as quickly as possible (anticlockwise).
16. Replace the inflation hose protective cap and the tyre valve cap.
17. Ensure that the tyre repair kit (including the bottle and receiver caps) are placed securely in the vehicle. You will need to use the kit to check the tyre pressure after approximately 3 km (2 miles), so ensure they are easily accessible.
18. Immediately drive the vehicle for approximately 3 km (2 miles), to allow the sealant to coat the inner surface of the tyre and form a seal at the puncture.

CHECKING THE TYRE PRESSURE AFTER A REPAIR



When driving the vehicle, if you experience vibrations, abnormal steering, or noises, reduce speed immediately. Drive with extreme caution and reduced speed, to the first safe place to stop the vehicle. Visually examine the tyre and check its pressure. If there are any signs of damage or deformity to the tyre, or the tyre pressure is below 1.3 bar (19 psi), do not continue driving.



Consult a tyre repair centre or your Dealer/Authorised Repairer, for advice concerning the replacement of a tyre after using a tyre repair kit.



1. Drive the vehicle for 3 km (2 miles) then stop in a safe place. Carry out a visual examination of the tyre's condition.
2. Make sure that the sealant container section is in its original position.
3. Screw the inflation hose connector firmly onto the tyre valve.
4. Read the tyre pressure from the gauge.
5. If the pressure of the sealant filled tyre is above 1.3 bar (19 psi) adjust the pressure to the correct value.
6. Ensure that the compressor switch is in the off (O) position and insert the power cable connector into the auxiliary power socket. If the vehicle is in a well ventilated area, start the engine.
7. Switch the compressor to on (I) and inflate the tyre to the correct pressure.
8. To check the tyre pressure, turn off the compressor then read the pressure from the gauge.

9. When the compressor is off, if the tyre pressure is too high, release the required amount of pressure using the pressure release valve.
10. Once the tyre is inflated to the correct pressure, switch off the compressor and remove the power plug from the auxiliary socket.
 - The use of the tyre repair kit sealant may lead to error prompts and incorrect readings of the Tyre Pressure Monitoring System. Therefore, use the tyre repair kit pressure gauge to check and adjust the damaged tyre's inflation pressure.
11. Unscrew the inflation hose connector from the tyre valve, replace the tyre valve cap and the inflation hose connector protective cap.
12. Ensure that the tyre repair kit is placed securely in the vehicle.
13. Drive to the nearest tyre repair centre or Dealer/Authorised Repairer, for a replacement tyre to be fitted. Ensure that you make the repair centre aware that the tyre repair kit has been used before the tyre is removed.
14. The tyre inflation hose, the receiver and the sealant bottle must be replaced once a new tyre has been fitted.





Only sealant bottles which are completely empty should be disposed of with normal household waste. Sealant bottles which contain some sealant, and the tyre inflation hose, should be disposed of by a tyre specialist or your Dealer/Authorised Repairer in compliance with local waste disposal regulations.

SAFETY PRECAUTIONS

-  **Avoid exposing the fuel gasses to any potential sources of ignition as the resulting fire and explosion may cause serious injuries and/or death.**
-  **Switch off the engine when refuelling, as it is both a source of extreme temperatures, and electrical sparks.**
-  **Switch off any personal electronic devices such as mobile phones or music players.**

PETROL ENGINED VEHICLES



-  Do not use leaded fuels, lead substitutes, or fuel additives.
-  Fuel system cleaning agents should not be used, unless approved by Land Rover.

OCTANE RATING

The minimum octane rating for fuel used is 95 RON. The vehicle will run on lower ratings, but it may cause pronounced engine knock or pinking. If the pinking is severe it can cause damage to the engine, fuel and emission control systems.

Note: *Occasional, light, engine knock experienced while accelerating or climbing hills is acceptable.*

ETHANOL

-  This vehicle is not suitable for use with fuels containing more than 10% ethanol.
-  Do not use E85 fuels (85% ethanol content). Equipment necessary for the use of fuels containing more than 10% ethanol is not fitted to this vehicle. If E85 fuels are used, serious engine and fuel system damage will occur.

Fuels containing up to 10% Ethanol (grain alcohol) may be used. Ensure that the fuel has octane ratings no lower than those recommended for unleaded fuel. Most drivers will not notice any operating difference with fuel containing Ethanol. If a difference is detected, the use of conventional unleaded fuel should be resumed.

METHANOL

-  Wherever possible avoid using fuel containing methanol.

Some fuels contain methanol (methyl or wood alcohol). If you use fuels containing methanol the fuels must also contain co-solvents and corrosion inhibitors for methanol. Also, do not use fuels which contain more than 3% methanol even if they contain co-solvents and corrosion inhibitors. Fuel system damage or vehicle performance problems resulting from the use of such fuels is not the responsibility of Land Rover, and may not be covered under the warranty.

METHYL TERTIARY BUTYL ETHER (MTBE)

Unleaded fuel containing an oxygenate known as MTBE can be used provided that the ratio of MTBE to conventional fuel does not exceed 15%. MTBE is an Ether based compound derived from Petroleum, which has been specified by several refiners as the substance to enhance the Octane rating of fuel.

REFORMULATED GASOLINE

These fuels are specially formulated to further reduce vehicle emissions. Land Rover fully supports all efforts to protect and maintain ambient air quality, and encourages the use of reformulated gasoline where available.

DIESEL ENGINED VEHICLES

Land Rover recommends that only premium brand diesel fuels are used.

Note: *Land Rover vehicles are capable of running with up to a 5% blend of bio-diesel in accordance with European Standard EN590.*

SULPHUR CONTENT

 If your vehicle is fitted with a Diesel Particulate Filter (DPF) the maximum Sulphur content must not exceed 0.005%. Using an incorrect fuel will cause serious damage to the DPF.

The Sulphur content of diesel used in Land Rover vehicles should not exceed 0.3% (3000 parts per million).

In some countries diesel will contain higher levels of Sulphur, which will require reduced service intervals to reduce the effects on engine components. If in doubt contact a local Land Rover Dealer/Authorised Repairer for advice.

RUNNING OUT OF FUEL

 Avoid running out of fuel. Doing so can cause damage to the vehicle's engine, fuel, and emission control systems.

If the vehicle does run out of fuel, a minimum of 4 litres (0.9 gallons) will be required to restart the engine. The vehicle should be left with the ignition on for 5 minutes after refuelling before attempting to restart the engine. The vehicle will need to be driven 1.6 - 5 km (1 - 3 miles) in order to reset the engine management and monitoring systems.

Note: *If the vehicle does run out of fuel, seeking qualified assistance is advisable.*

Diesel engines

Vehicles with diesel engines are equipped with a system to prevent the fuel tank from emptying completely. When the fuel reaches a minimum level, the system will activate a reduced power mode (i.e. the engine will not run properly). This will be followed by the engine stopping in approximately 1.6 km (1 mile).

This feature prevents the fuel system from running dry, which could cause damage to the vehicle. If the gauge indicates low fuel or the warning indicator illuminates, the fuel tank should be refuelled as soon as possible at the next filling station, with at least 4 litres (0.9 gallons) of fuel.

If the system protection function has activated, the vehicle must firstly be refuelled, then restarted using the following procedure:

1. With the brake pedal pressed, press and hold the engine START/STOP button and crank the engine for five seconds.
2. Release the START/STOP button.
3. With the brake pedal pressed, press and release the START/STOP button to crank the engine. The engine should start within approximately five seconds.

Note: *If the engine does not start, pause for ten seconds with the ignition in convenience mode, before repeating the procedure from the beginning.*

 Do not crank the engine for longer than 30 seconds continuously.

FUEL FILLER FLAP

-  Take note of all warnings and instructions given on the label affixed to the inside of the filler flap.

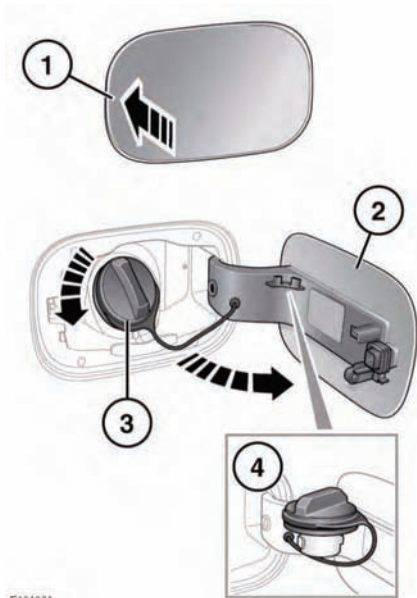





E134804

The fuel filler flap is located on the right-hand side of the vehicle, at the rear.

1. Ensure that the vehicle is fully unlocked, and press the left side of the flap to open.
2. Open the flap fully.
3. Twist the cap anticlockwise to undo.
4. Use the retaining clip to keep the filler cap out of the way whilst fuelling.

FUEL FILLER

-  When refuelling ensure that all windows, doors, and sunroof are fully closed, particularly if young children or animals are in the vehicle.
-  Do not attempt to fill the tank to its maximum capacity. If the vehicle is to be parked on a slope, in direct sunlight, or high ambient temperature, expansion of the fuel could cause spillage.
-  Do not operate the auxiliary heater when refuelling the vehicle. Doing so may cause fuel vapours to combust causing a fire/explosion.
-  Check the fuel pump information carefully, to ensure that you are putting the correct fuel into the vehicle.
-  If the vehicle is filled with incorrect fuel it is essential that you seek qualified assistance before you start the engine.

Filling station pumps are equipped with automatic cut-off sensing to avoid fuel spillage. Fill the tank until the filler nozzle automatically cuts-off the supply. Do not attempt to fill the tank beyond this point.

Note: *Filling station pumps used for diesel commercial vehicles deliver fuel at a higher rate than normal. The higher fill rate can cause premature cut-off and may cause fuel spillage. Therefore, it is recommended that only standard light vehicle pumps are used.*

WATER IN FUEL



If the warning **WATER IN FUEL SEE HANDBOOK** is displayed in the message centre, an excessive amount of water has collected in the fuel filter bowl. Seek assistance from a Land Rover Dealer/Authorised Repairer to have the filter drained as soon as possible.

FUEL TANK CAPACITY

Avoid the risk of running out of fuel and never intentionally drive the vehicle when the fuel gauge indicates that the tank is empty. When refuelling your vehicle after the fuel gauge reads empty, you may not be able to add the fuel quantity shown below, as there will be a small reserve remaining in the tank.

| | |
|-------------------------------|------------------------|
| Total tank capacity (usable): | |
| Petrol engines | 86 litres (19 gallons) |
| Diesel engines | 82 litres (18 gallons) |

FUEL SPECIFICATION

| Petrol | Diesel |
|-----------|--------|
| 91-98 RON | EN 590 |



Diesel vehicles in Algeria, Egypt, Libya, Morocco, India, Pakistan and Tunisia must only use premium diesel fuel.

DIESEL MISFUELLING PROTECTION DEVICE

 **When the misfuelling device is activated, it may cause fuel to be discharged from the filler neck.**

Note: It is the driver's responsibility to fill the vehicle with the correct fuel. The diesel misfuel protection device only reduces the risk of filling the vehicle with the incorrect fuel.

Diesel engine vehicles in some markets are equipped with a misfuelling protection device, incorporated into the fuel filler neck.

If the narrow filler nozzle fitted to pumps delivering unleaded petrol is fully inserted into the filler neck, the misfuel protection device will activate.

Note: The filler spout on some fuel cans and older fuel pumps may trigger the misfuelling device.

When activated, the yellow misfuel protector will be visible inside the filler neck. It will prevent fuel flow into the tank. Before fuelling can continue with the correct fuel, the device will need to be reset.

The reset tool is located in the luggage compartment.

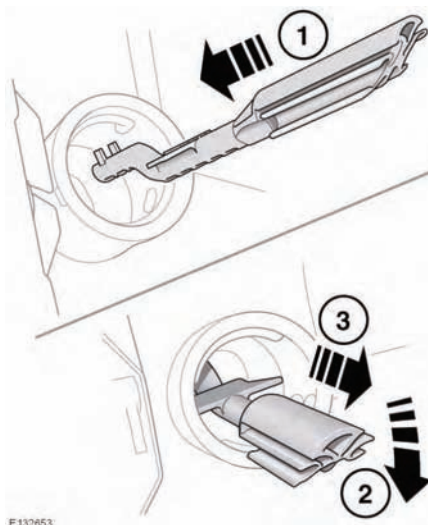

Reset the misfuel protection device as follows:

1. Insert the reset tool (with the teeth uppermost) as far as it will go into the filler neck.
2. Locate the teeth by pushing down the top of the reset tool.
3. With the top of the tool pressed down and the teeth engaged, slowly pull the tool out of the filler neck to reset the device.

 Do not twist the device, once the teeth have engaged.

Note: The yellow part of the protection device should no longer be visible in the filler neck.

Return the reset tool to the luggage compartment.

FUEL CONSUMPTION

The fuel consumption figures shown below have been calculated using a standard testing procedure (the new EC test procedure from Directive 99/100/EC), and produced in accordance with The Passenger Car Fuel Consumption (Amendment) Order 1996.

Under normal use, a vehicle's actual fuel consumption figures may differ from those achieved through the test procedure, depending on driving technique, road and traffic conditions, environmental factors, vehicle load and condition.

| Variant | Urban | Extra-urban | Combined | CO2 emissions |
|---|----------------|----------------|----------------|---------------|
| | l/100 km (mpg) | l/100 km (mpg) | l/100 km (mpg) | g/km |
| 2.7 V6 Diesel | 13.1 (21.6) | 8.5 (33.2) | 10.2 (27.7) | 270 |
| 3.0 V6 Diesel (6 speed transmission) | 11.2 (25.2) | 8.3 (34.0) | 9.3 (30.4) | 244 |
| 3.0 V6 Diesel (155kW)(8 speed transmission) | 9.7 (29.1) | 7.8 (36.2) | 8.5 (33.2) | 224 |
| 3.0 V6 Diesel (188kW)(8 speed transmission) | 9.8 (28.8) | 8.1 (34.9) | 8.8 (32.1) | 230 |
| V8 Petrol | 19.8 (14.3) | 10.7 (26.5) | 14.1 (20.1) | 328 |

URBAN CYCLE

The urban test cycle is carried out from a cold start and consists of a series of accelerations, decelerations and periods of steady speed driving and engine idling. The maximum speed attained during the test is 50 km/h (30 mph) with an average speed of 19 km/h (12 mph).

EXTRA-URBAN CYCLE

The extra-urban test cycle is carried out immediately after the urban test. Approximately half of the test comprises steady speed driving, while the remainder consists of a series of accelerations, decelerations and engine idling. The maximum test speed is 120 km/h (75 mph) and the average speed 63 km/h (39 mph). The test is carried out over a distance of 7 km (4.3 miles).

COMBINED

The combined figure is an average of the urban and extra-urban test cycle results, which has been weighted to take account of the different distances covered during the two tests.

For additional information on fuel consumption figures and exhaust emissions, visit the Vehicle Certification Agency (VCA) website at <http://www.vcacarfueldata.org.uk/>.



DISABILITY MODIFICATIONS

Occupants with disabilities which may require modification of the vehicle, must contact a Dealer/Authorised Repairer before any modifications are made.

AIRBAG SYSTEM



The components that make up the airbag system are sensitive to electrical or physical interference, either of which could easily damage the system and cause inadvertent operation or a malfunction of the airbag module.

To prevent malfunction of the airbag system always consult your Dealer/Authorised Repairer before fitting any of the following:

- Electronic equipment such as a mobile phone, two-way radio or in-car entertainment system.
- Accessories attached to the front of the vehicle.
- Any modification to the front of the vehicle.
- Any modification involving the removal or repair of any wiring or component in the vicinity of any of the airbag system components, including the steering wheel, steering column, instrument or fascia panels.
- Any modification to the fascia panels or steering wheel.

ANTI-THEFT SYSTEM



No modifications or additions should be made to the anti-theft system. Such changes could cause the system to malfunction.

OWNER MAINTENANCE



Any significant or sudden drop in fluid levels, or uneven tyre wear, should be reported to a qualified technician without delay.

In addition to the routine maintenance, a number of simple checks must be carried out more frequently.

DAILY CHECKS

- Operation of lamps, horn, direction indicators, wipers, washers and warning lamps.
- Operation of seat belts and brakes.
- Look for fluid deposits underneath the vehicle that might indicate a leak.

WEEKLY CHECKS

- Engine oil level.
- Engine coolant check.
- Brake/clutch fluid level.
- Power steering fluid level.
- Screen washer fluid level.
- Tyre pressures and condition.
- Operate air conditioning.

Note: *The engine oil level should be checked more frequently if the vehicle is driven for prolonged periods at high speeds.*

ARDUOUS DRIVING CONDITIONS

When a vehicle is operated in extremely arduous conditions, more frequent attention must be paid to servicing requirements.

Arduous driving conditions include:

- Driving in dusty and/or sandy conditions.
- Driving on rough and/or muddy roads and/or wading.
- Driving in extremely hot/cold conditions.

- Towing a trailer or driving in mountainous conditions.
- Driving in areas using road salt or other corrosive materials on the driving surface.

Contact a Dealer/Authorised Repairer for advice.

DIESEL PARTICULATE FILTER (DPF)

Diesel vehicles equipped with a particle filter have more efficient emission control. The particles in the exhaust gases are collected in the filter during normal driving.

When a DPF message is displayed, the filter requires a regeneration cycle to clean itself. This requires the engine to have reached normal operating temperature. Regeneration takes place automatically at an interval of approximately 300-900 km (190-560 miles) depending on driving conditions. Regeneration normally takes 10-20 minutes and is automatically requested by the engine control module if the vehicle is driven steadily at vehicle speeds between 40mph to 70mph. It is possible that the regeneration process will occur at lower vehicle speeds, but the events may take a little longer at a 50 km/h (30mph) average speed.

DRIVING SHORT DISTANCES OR IN COLD WEATHER

If the vehicle is frequently driven short distances or in cold weather conditions then the engine may not reach normal operating temperature. This means that regeneration of the diesel particle filter does not take place and the filter is not efficiently cleaned. When the filter reaches a condition when a filter regeneration is appropriate and the current drive style is not appropriate, a warning triangle on the instrument panel illuminates, and the message **DPF Full. See manual** is displayed on the instrument panel. This is not

indicating a fault condition with the vehicle and no dealership support should be required. Start regeneration of the filter by driving the vehicle, preferably on a main road or motorway. The vehicle should then be driven for approximately 20 minutes or more.

When regeneration is complete the warning text is cleared automatically.

***Note:** A small increase in fuel consumption may be noticed temporarily during regeneration.*

ROAD TESTING DYNAMOMETERS (ROLLING ROADS)

It is essential that any dynamometer testing is carried out only by a qualified person, familiar with the dynamometer testing and safety procedures practised by a Dealers/Authorised Repairers.

SAFETY IN THE GARAGE



If the vehicle has been driven recently, do not touch the engine, exhaust and cooling system components until the engine has cooled.



Never leave the engine running in an unventilated area - exhaust gases are poisonous and extremely dangerous.



that no person should place any portion of their body under a vehicle that is supported by a jack.



Keep your hands and clothing away from drive belts, pulleys and fans. Some fans may continue to operate or start operating after the engine has stopped.



Remove metal wrist bands and jewellery, before working in the engine compartment.

 Do not touch electrical leads or components while the engine is running, or with the starter switch turned on.

 Do not allow tools or metal parts of the vehicle to make contact with the battery leads or terminals.

FUEL SYSTEM

 Under no circumstances should any part of the fuel system be dismantled or replaced by anyone other than a suitably qualified vehicle technician.

 Ensure sparks and naked lights are kept away from the engine compartment.

 Wear protective clothing, including, where practicable, gloves made from an impervious material.

USED ENGINE OIL

Prolonged contact with engine oil may cause serious skin disorders, including dermatitis and cancer of the skin. Always wash thoroughly after contact.



It is illegal to pollute drains, water courses or soil. Use authorised waste disposal sites to dispose of used oil and toxic chemicals.

OPENING THE BONNET

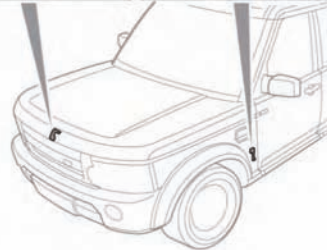
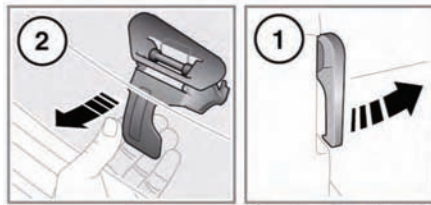

E134966

1. Pull the bonnet release lever, located in the left-hand front footwell.
2. Lift the bonnet safety catch lever, located below the centre point of the bonnet, then raise the bonnet.

CLOSING THE BONNET

 Do not drive with the bonnet retained by the safety catch alone.

- Lower the bonnet until the safety catch engages. Using both hands, press the bonnet down until the catches click.
- Check that both catches are engaged, by trying to lift the front edge of the bonnet.

ENGINE COMPARTMENT OVERVIEW

2.7 V6 Diesel

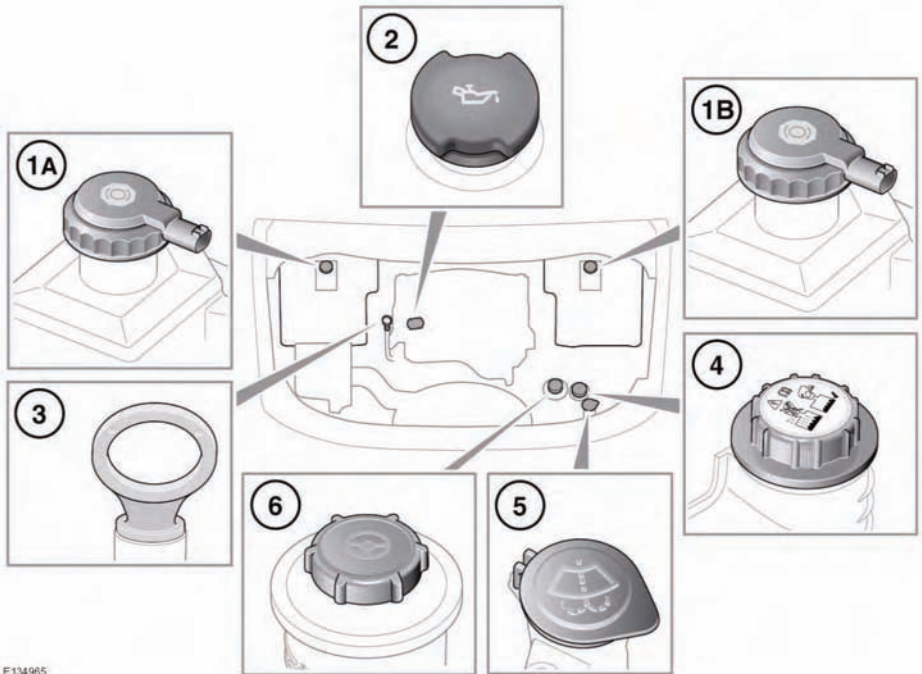

E134965

1. Brake fluid reservoir cap:
 - A. Right-hand drive vehicles.
 - B. Left-hand drive vehicles.
2. Engine oil filler cap.
3. Oil level dipstick.
4. Engine coolant filler cap.
5. Windscreen washer fluid filler cap
6. Power steering fluid filler cap.



Do not drive if there is a possibility that leaked fluid will come into contact with a hot surface, such as the exhaust.

3.0 V6 Diesel and V8 Petrol

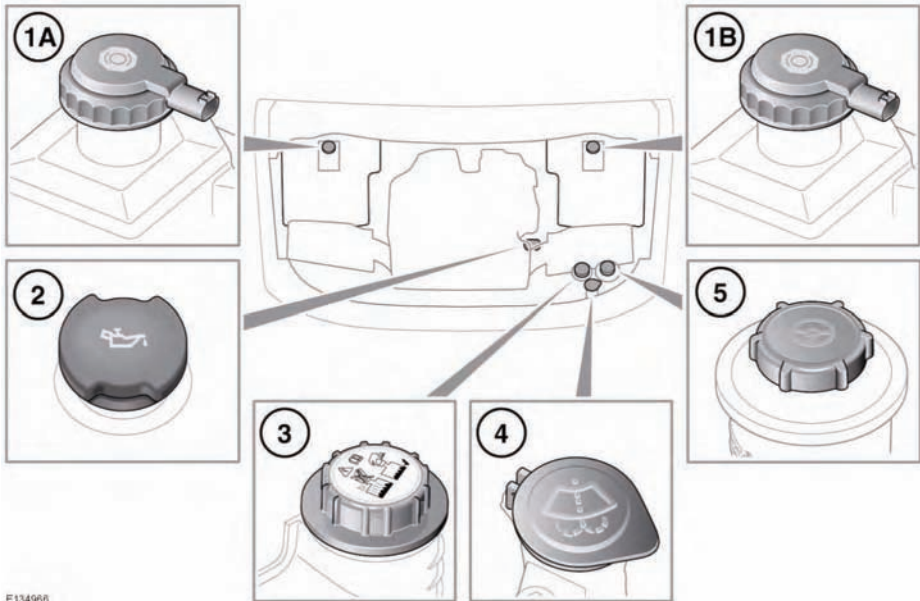

E134966

1. Brake fluid reservoir cap:
 - A. Right-hand drive vehicles.
 - B. Left-hand drive vehicles.
2. Engine oil filler cap.
3. Engine coolant filler cap.
4. Windscreen washer fluid filler cap.
5. Power steering fluid filler cap.

! Do not drive if there is a possibility that leaked fluid will come into contact with a hot surface, such as the exhaust.

UNDER BONNET COVERS - REMOVAL

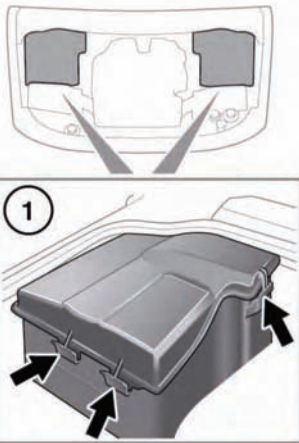

E134967

1. Press the tabs to release the cover from the casing.

Note: Releasing the inboard tab on the front edge of the cover first will make it easier to release the remaining tabs.

2. Lift the front edge of the cover and slide forwards to remove.

UNDER BONNET COVERS - REFITTING

- ⚠ Before refitting the underbonnet covers, ensure that no pipes, cables or other items, have been trapped between the cover and casing.

1. Slide the rear edge of the cover under the rubber trim fitted to the scuttle panel.
2. Make sure the front edge of the cover is flush to the casing, and then press down until the cover clicks into place.

UNBLOCKING WASHER JETS



Do not operate the washer jets during unblocking or adjustment.

Windscreen washer fluid may cause irritation to the eyes and skin. Always read and observe the washer fluid manufacturers instructions.

If a washer jet becomes blocked, use a thin strand of wire to unblock the jet by inserting the wire into the jet. Ensure that the wire is completely removed after unblocking. The washer jet position may also be adjusted by inserting the point of a needle into the jet and gently repositioning it.

CHANGING A BULB



Before attempting a bulb change, ensure that the ignition and the affected lamp are turned off.



Always replace bulbs with the correct type and specification. If you are in any doubt contact your Land Rover Dealer/Authorised Repairer for advice.

Note: In certain territories it is a legal requirement to carry spare bulbs. A replacement bulb kit is available as an approved accessory from your dealer.

Note: After replacing a headlamp bulb, headlamp alignment should be checked with the appropriate equipment.

HEADLAMP REMOVAL

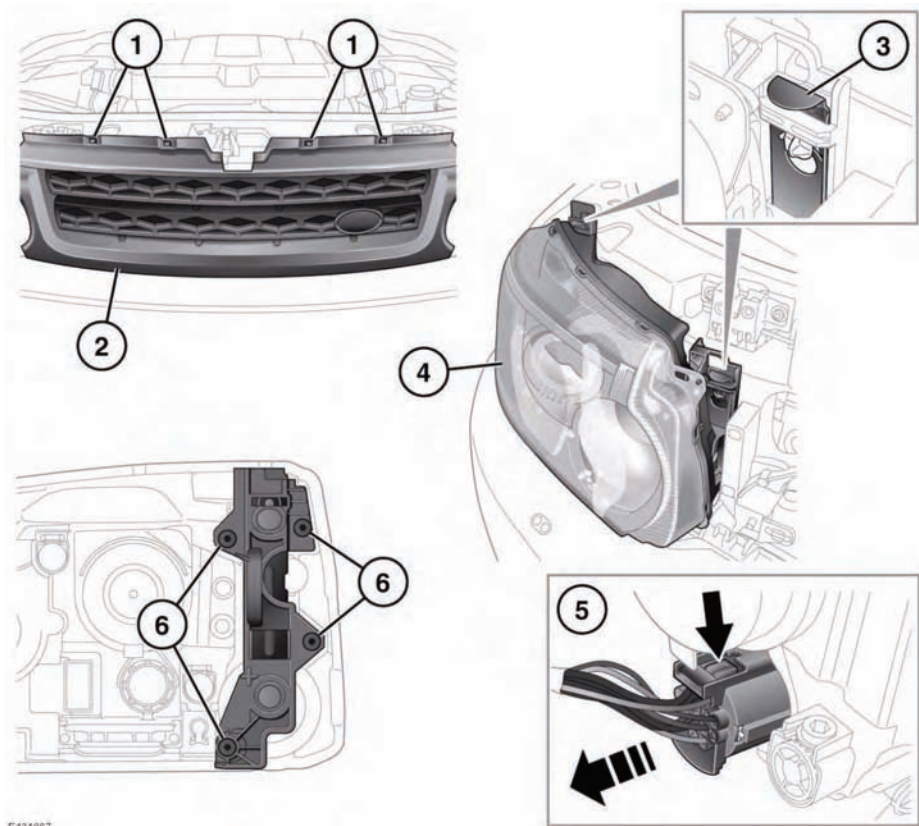

E134867

- !** Do not place the removed lamp unit face down on hard or abrasive surfaces. Doing so may scratch the surface of the lens.
1. Press down on the four upper clips, and gently pulling the grill forwards.
 2. Lift the grille clear of the vehicle and place where it will not be damaged.
 3. Carefully lever up the locking tabs securing the rear of the headlamp. Hold the headlamp in position while doing so.

4. Holding the front of the lamp, lift forwards and clear of the body.

Note: The locking tabs (3) can be levered too far up, preventing the headlamp being released. If this happens ease the tabs down until the headlamp can be moved forward.

5. Disconnect the electrical connector from the back of the unit and remove the unit from the vehicle.

Note: Place face down on a flat surface covered in a soft material to prevent damage to the units lenses

- To access the direction indicator, static bending lamp and side lamp, the headlamp unit locking slide assembly must be completely removed from the unit.

To remove the slide assembly, remove the four screws (arrowed). When refitting the slide, do not overtighten the screws.

Note: Refitting the headlamp unit is the reverse of removal.

HEADLAMP BULB IDENTIFICATION

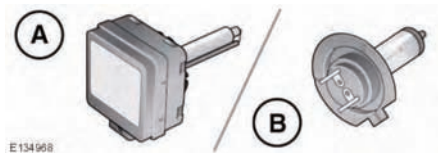



- A. Xenon bulb.
- B. Halogen bulb.

HALOGEN BULBS

Dependent on vehicle specification, halogen bulbs may be used for high beam, low beam, and front fog lamps. Take care not to touch the glass part of the bulb with your fingers; always use a cloth to handle the bulb. If necessary use methylated spirits to remove finger prints.

XENON LAMPS

-  **Replacement or maintenance of Xenon lamps should only be carried out by suitably qualified personnel.**
-  **High voltage is required to ignite the gas and metal vapour which are used to power Xenon lamps. Contact with this voltage can cause serious injury.**



Xenon lamp units operate at a very high temperature. Ensure that the lamp units have cooled before attempting to touch them.



Xenon lamp units contain Mercury which is highly toxic, and can be extremely harmful.



Seek advice about the correct disposal of Xenon lamp units from a Land Rover Dealer/Authorised Repairer, or your local authority.

XENON HEADLAMP BULB REPLACEMENT



Replacement or maintenance of Xenon lamps should only be carried out by suitably qualified personnel.



High voltage is required to ignite the gas and metal vapour which are used to power Xenon lamps. Contact with this voltage can cause serious injury.



Xenon lamp units operate at a very high temperature. Ensure that the lamp units have cooled before attempting to touch them.



Xenon lamp units contain Mercury which is highly toxic, and can be extremely harmful.



Seek advice about the correct disposal of Xenon lamp units from a Land Rover Dealer/Authorised Repairer, or your local authority.

HEADLAMP BULB REPLACEMENT - HALOGEN LOW BEAM

- !** Take care not to touch this type of bulb with your fingers; always use a cloth to handle them. If necessary, clean the bulb with methylated spirits to remove fingerprints.

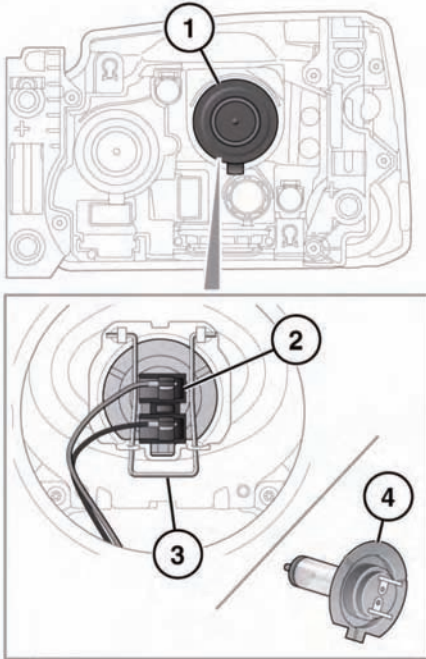

E134970

1. Twist and lift off the domed cap.
2. Pull off the electrical connector.
3. Release the spring clip securing the bulb to the lamp and remove the bulb.
4. Insert the new bulb and repeat the above procedure in reverse order.

HEADLAMP BULB REPLACEMENT - HALOGEN HIGH BEAM

- !** Take care not to touch this type of bulb with your fingers; always use a cloth to handle them. If necessary, clean the bulb with methylated spirits to remove fingerprints.

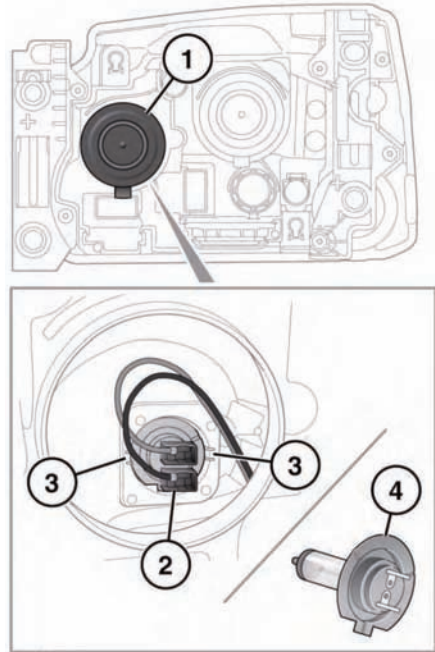

E134971

1. Twist and lift off the domed cap.
2. Pull off the electrical connector.
3. Release the bulb from the retaining tags and remove bulb.
4. Insert the new bulb and repeat the above procedure in reverse order.

STATIC BENDING BULB REPLACEMENT

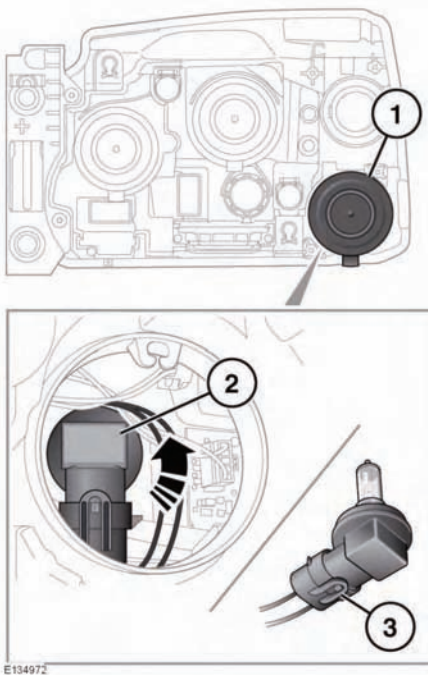

1. Twist and lift off the domed cap.
2. Rotate bulb holder and release from lamp.
3. Lift the tab and disconnect the electrical connector to remove.

SIDE LAMP BULB REPLACEMENT

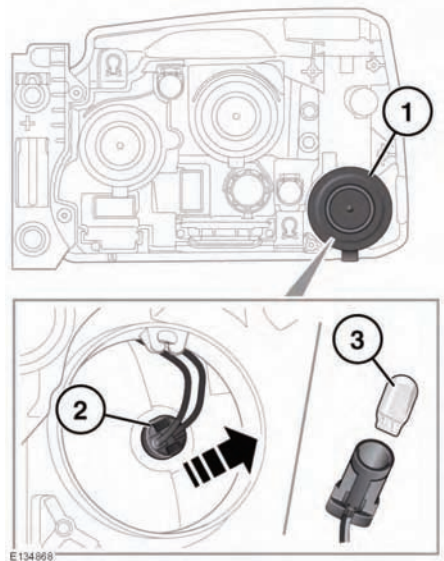

1. Twist and lift off the domed cap.
2. Press the two tabs and pull bulb holder from lamp.
3. Pull bulb from holder to remove.

FRONT FOG LAMP BULB REPLACEMENT

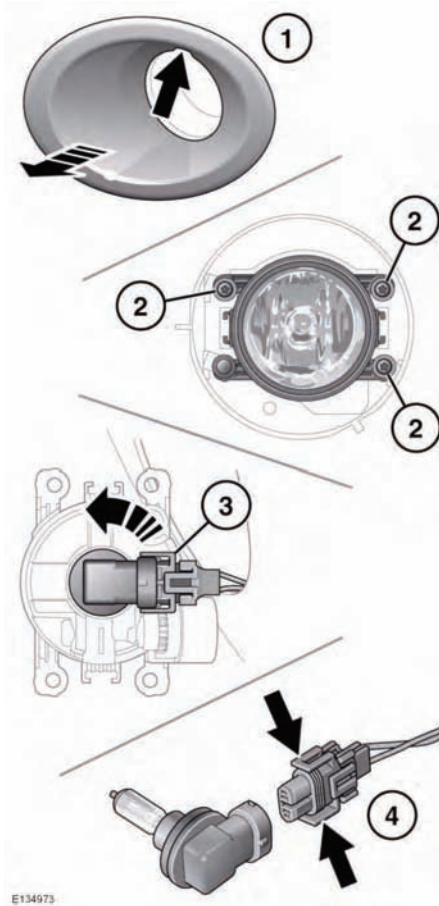

1. Using the finger slot at the top of the lamp surround, pull to remove.
2. Undo the three retaining screws, and remove the lamp unit.
3. Rotate the bulb holder (anticlockwise) and remove from the lamp unit.
4. Press the two clips together, and remove the electrical connector.

DIRECTION INDICATOR BULB REPLACEMENT

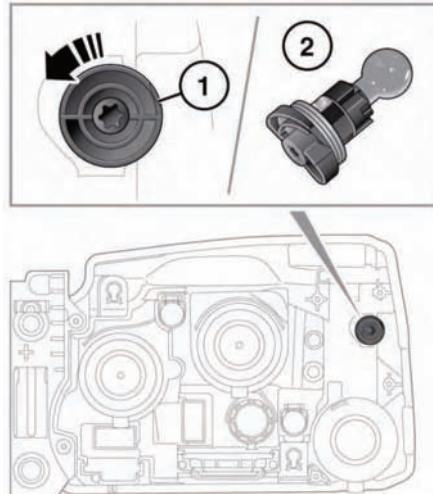

1. Rotate the bulb holder 45 degrees anticlockwise.
2. Remove the bulb assembly from the lamp. Push and twist to remove the bulb.

REAR LAMP REMOVAL

To change any of the rear bulbs, it is necessary to completely remove the lamp unit from the vehicle.

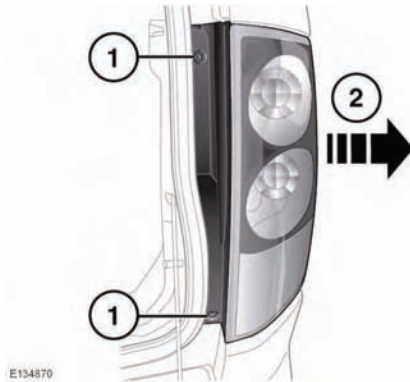

1. With the tailgate open, remove the two screws from the inner edge of the unit.
2. Pull the unit carefully away from the vehicle.
3. Disconnect the electrical connector and remove the unit from the vehicle. Place face down on a flat surface covered in soft material to prevent damage.
4. Refitting the lamp unit is the reverse of removal.

REAR LAMP - BULB REPLACEMENT

Note: The direction indicator lamp, stop lamp, and tail lamp are LED units, and cannot be serviced.

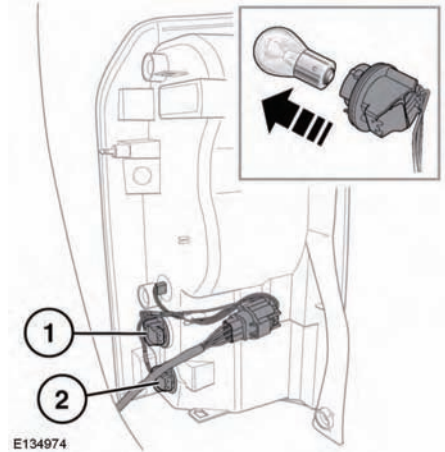

1. Reversing lamp
2. Rear fog lamp.

Twist the relevant bulb unit and pull to access the bulb. Push, twist and pull to remove the bulb.

SIDE REPEATER LAMP BULB REPLACEMENT

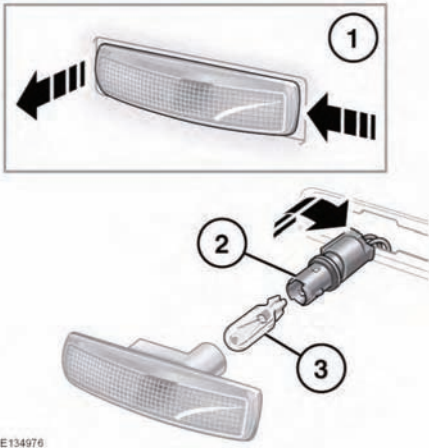

Follow the steps illustrated. Insert a new bulb and refit the components.

LICENSE PLATE LAMP BULB REPLACEMENT

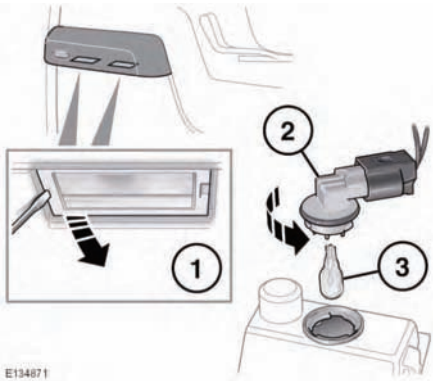

Follow the steps illustrated. Insert a new bulb and refit the components.

INTERIOR LAMP BULB REPLACEMENT

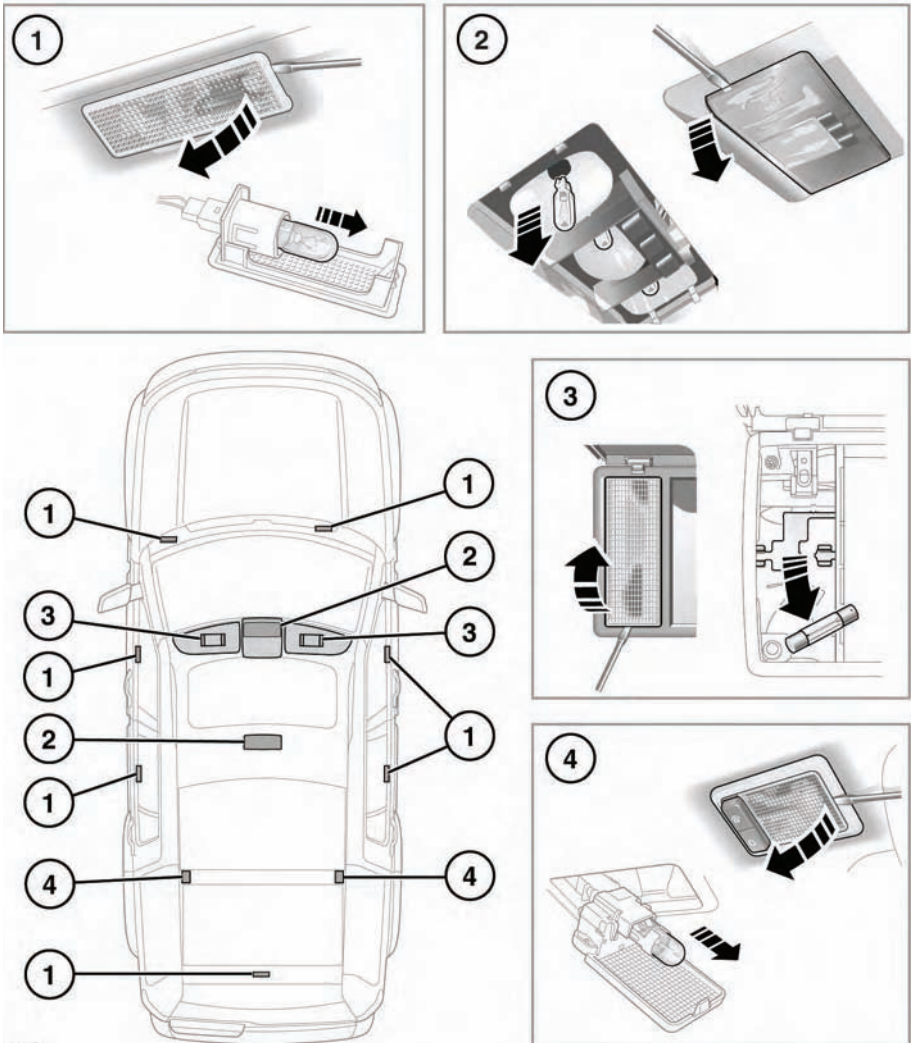

E135501

Follow the steps illustrated. Insert a new bulb and refit the components.

1. Footwell, puddle and loadspace lamps.
2. Front and rear courtesy lamps and map lamps.
3. Vanity mirror lamps.
4. Third row seat courtesy lamps.

WINDOW RESET

The windows will need to be reset if the battery is disconnected, becomes discharged or power supply is interrupted.

Reset as follows:

1. Close the window fully.
2. Release the switch, then lift it to the close position and hold for 1 second.
3. Repeat the procedure on each window.

SUNROOF RESET

If the battery is disconnected or the power supply is interrupted whilst the sunroof is partially open, it will need to be recalibrated.

Once the battery is reconnected or the power supply is restored, recalibrate the sunroof as follows:

1. Switch the ignition on.
2. With the sunroof closed, press and release the front of the switch. The sunroof will move to the tilted position.
3. Press the front of the sunroof switch and hold for 20 seconds.
4. After 20 seconds, the sunroof will begin to move. Keep the front of the switch pressed until the fully open/close cycle has completed.
5. Once the sunroof has stopped moving, release the switch.

The sunroof can now be operated as normal.

PARTS AND ACCESSORIES



The fitting of non-approved parts and accessories, or the carrying out of non-approved alterations or conversions, may be dangerous and could affect the safety of the vehicle and occupants and also invalidate the terms and conditions of the vehicle warranty.



Land Rover will not accept any liability for death, personal injury or damage to property which may occur as a direct result of fitment of non-approved accessories or the carrying out of non-approved conversions to Land Rover vehicles.

CLEANING THE EXTERIOR



Remove any heavy deposits of mud and dirt with a hose, before washing the vehicle.



Never aim the water jet directly at the engine air intake, heater air intakes, body seals (doors, sunroof, windows etc.) or at any components which may be damaged (lights, mirrors, exterior trim etc.).



Do not use a power wash system in the engine bay area.



Following cleaning of the vehicle exterior (particularly with a pressure washer), it is recommended that the vehicle is taken for a short drive to dry out the brakes.



Substances which are corrosive, such as bird droppings, can damage the vehicle's paintwork and should be removed as soon as possible.



Use only cleaning products approved for use on vehicles.

- ⚠ Do not apply polish to any unpainted areas of bumper mouldings. It will become ingrained in the textured finish.

UNDER BODY MAINTENANCE

Regularly flush the underbody with plain water, and pay particular attention to areas where mud and debris collect.

If damage or corrosion are detected, have the vehicle checked by a Land Rover Dealer/Authorised Repairer as soon as possible.

CLEANING AFTER OFF-ROAD DRIVING

- ⚠ Ensure that the areas around air intakes and the front grille are clean and clear of debris. Pay particular attention to the lower grille and radiator. Failure to do so may cause the engine to overheat, leading to severe engine damage.

Ensure that the vehicle underside is cleaned as soon as possible after driving off-road.

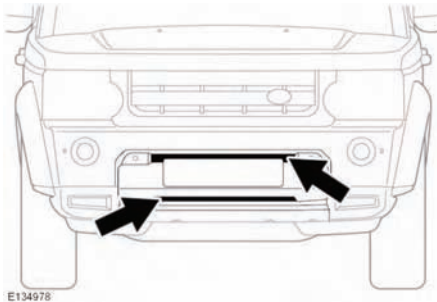

Using a hose pipe, direct clean water through the front bumper (where shown), to remove mud on the radiator and air conditioning condenser.

CLEANING THE INTERIOR

- ⚠ Some cleaning products contain substances that are harmful and can cause health problems if used incorrectly and may cause damage to the interior.

CLEANING FABRIC UPHOLSTERY

- ⚠ Do not polish the instrument panel. Polished surfaces are reflective, and may interfere with the drivers view.

Clean plastic or cloth faced surfaces with warm water and non-detergent soap. Then wipe clean with a soft cloth.

LEATHER

- ⚠ Only use cleaning products specifically designed for use on leather. Do not use chemical, alcohol, or abrasive materials, as they will cause rapid deterioration of the leather. The use of products which are not approved will invalidate your warranty.
- ⚠ If you are in any doubt as to which products to use, consult your Land Rover Dealer/Approved Repairer.

Leather should be cleaned and protected at least every six months.

To prevent ingrained dirt and staining, inspect the seat upholstery regularly, and clean every 1 to 2 months as follows:

1. Wipe off fine dust from the seat surfaces using a clean, damp, non-coloured cloth. Avoid over wetting the leather.
2. If this is not sufficient, use a cloth which has been dampened with warm soapy water and then wrung out. Use only mild non-caustic soap.

3. Use Land Rover leather cleaner for heavily soiled areas. Dry off and rub the with a clean soft cloth, changing surfaces regularly.

Use Land Rover leather cleaner several times a year to maintain the leather's suppleness and appearance. The cleaner will nourish and moisturise and help to improve the surface protection film against dust and substances.

- Dark clothing may stain leather seats just like other upholstery products.
- Sharp objects such as belts, zippers, rivets etc can leave permanent scratches and scratch marks on the leather surface.
- Unless spillages such as tea, coffee or ink are washed away immediately, permanent staining may have to be accepted.

If a valet service is used, ensure that the specialist concerned is aware of, and follows, these instructions precisely.

Note: *Some materials/fabrics are prone to dye transfer, which can cause unsightly discolouration of lighter coloured leathers. Affected areas should be cleaned and re-protected as soon as possible.*

SEAT BELTS



Do not allow any water, cleaning products, or fabric from cloths to enter the seat belt mechanism. Any substance which enters the mechanism may affect the performance of the seat belt in an impact.

Extend the seat belts fully, then use warm water and a non-detergent soap to clean. Allow the seat belts to dry naturally whilst fully extended.

Note: *Whilst cleaning the seat belt, take the opportunity to examine the webbing for damage/wear. Any wear or damage should be reported to, and rectified by, a Land Rover Dealer/Approved Repairer.*

AIRBAG MODULE COVERS



Airbag covers should only be cleaned using a slightly dampened cloth, and a small amount of upholstery cleaner.



Do not allow the airbag covers, or surrounding areas, to become contaminated with liquids. Any substance which enters the mechanism can prevent correct deployment of an airbag during an impact.

CLEANING THE TOUCH SCREEN

- Clean with a lightly moistened cloth.
- Do not use chemical agents or domestic cleaners.
- To prevent errors occurring, ensure that only one finger at a time is in contact with the touch screen.
- Do not use excessive pressure.
- Do not allow sharp, hard or abrasive objects to make contact with the touch screen.
- Avoid exposing the touch screen to direct sunlight for long periods.

CHECKING THE ENGINE OIL LEVEL

2.7 V6 diesel engines

- ⓘ Check the engine oil weekly. If any significant or sudden drop in oil level is noted, seek qualified assistance.

Check the oil level when the engine is cold and with the vehicle resting on level ground.

Note: *If it is necessary to check the oil level when the engine is hot, switch off the engine and let the vehicle stand for 5 minutes to allow the oil to drain back into the sump. Do not start the engine.*

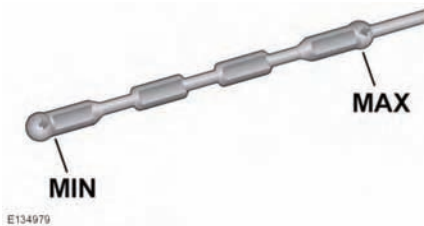

1. Withdraw the dipstick and wipe the blade clean with a lint free cloth.
2. Fully re-insert the dipstick and withdraw again to check the oil level. Never allow the oil level to fall below the lower mark or notch on the dipstick.

As a general guide, if the level on the dipstick:

- Is nearer to the upper mark or notch than the lower, add no oil.
- Is nearer to the lower mark or notch than the upper, add half a litre (one pint) of oil.
- Is below the lower mark or notch, add 1 litre (2 pints) of oil and re-check the level after a further 5 minutes.

3.0 V6 and V8 petrol engines

- ⓘ Check the engine oil weekly. If any significant or sudden drop in oil level is noted, seek qualified assistance.
- ⓘ If the message **ENGINE OIL PRESSURE LOW** is displayed, stop the engine as soon as it is safe to do so and seek qualified assistance. Do not start the engine until the cause has been rectified.

Prior to checking the oil level ensure that:

- The vehicle is on level ground.
- The engine oil has reached working temperature (oil is hot).
- The engine has been switched off for 10 minutes, as the system will not give an accurate reading until the oil level has stabilised.

The oil level can then be checked as follows:

1. Switch on the ignition (do not start the engine).
2. Ensure Park (**P**) is selected.
3. Select the **Service menu** using the driver information module menu control (see **52, INTERACTIVE CONTROLS**).

Select Oil level display from the Service menu. The current oil level status and topping-up advice is displayed in the instrument panel, top-up as instructed.



An indication of the oil level is displayed in the gauge. Messages to the right of the gauge advise you of any action you may need to take. If the oil level is within the required operating range, the message **Engine Oil Level OK** will be displayed. Do not add any additional oil to the engine.

If the oil level is below the required operating range, a message advising you how much oil to add will be displayed (e.g. **Add 0.5 Litre**). Add the recommended quantity of oil.

If the message **Engine Oil Level Overfilled** is displayed, seek qualified assistance immediately. Do not drive the vehicle as this will cause serious damage to the engine.

If the message **Engine Oil Level Underfilled** is displayed, add 1.5 litres (2.6 pints) of oil, then recheck the level.

If the message **Engine Oil Level Not Available** is displayed, the oil level is stabilising. Switch off the ignition, wait 10 minutes, then recheck the oil level display.

If the warning message **ENGINE OIL LEVEL MONITOR SYSTEM FAULT** is displayed, seek qualified assistance.

TOPPING UP THE OIL

- ❗ Your vehicle warranty may be invalidated if damage is caused by using oil that does not meet the required specification.
 - ❗ Failure to use an oil that meets the required specification could cause excessive engine wear, a build up of sludge and deposits, and increase pollution. It could also lead to engine failure.
 - ❗ Overfilling with oil could result in severe engine damage. Oil should be added in small quantities and the level re-checked to ensure that the engine is not overfilled.
1. Remove the oil filler cap.
 2. Add oil as instructed by the dipstick display (3.0 Diesel and V8 Petrol engines) or to maintain the level between the **MIN** and **MAX** marks or notches on the dipstick (2.7 Diesel engine).
 3. Clean up any oil spilled during topping-up.
 4. Check the oil level again after 10 minutes (3.0 Diesel and V8 Petrol engines) or after 5 minutes (2.7 Diesel engine).

It is essential to use the correct specification oil, and to ensure it is suitable for the climatic conditions in which the vehicle is to be operated.

Note: *The approximate quantity of oil required to raise the level from **MIN** to **MAX** on the dipstick is 1.5 litres (2.6 pints) for all models.*

ENGINE OIL SPECIFICATION

| Model | Specification |
|------------------|---|
| V8 Petrol engine | Use only 5W-20 oil meeting specification WSS-M2C925-A only. |
| Diesel engines | Use only 5W-30 oil meeting specification WSS-M2C934-B. |

Land Rover recommends:



CHECKING THE COOLANT LEVEL

! Running the engine without coolant will cause serious engine damage.

The coolant level in the expansion tank should be checked at least weekly (more frequently in high mileage or arduous operating conditions). Always check the level when the system is cold.

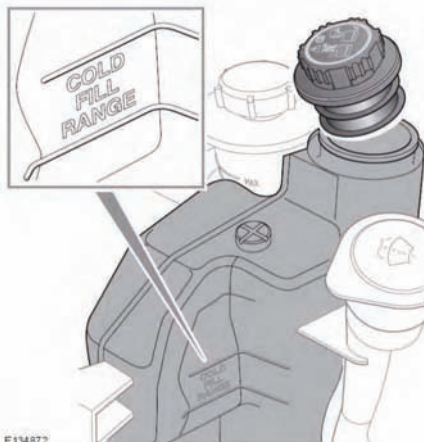

E134872

Ensure the coolant level remains between the COLD FILL RANGE indicator marks located on the side of the expansion tank. Ignore any coolant visible in the top section of the tank

If the level has dropped suddenly, or by a large amount, arrange for the vehicle to be examined by a qualified technician as soon as possible.

TOPPING UP THE COOLANT

! Never remove the filler cap when the engine is hot - escaping steam or scalding water could cause serious personal injury.

! Avoid spilling antifreeze onto a hot engine - a fire may result.

! Unscrew the filler cap slowly, allowing the pressure to escape before removing completely.

! Antifreeze is poisonous and can be fatal if swallowed - keep containers sealed and out of the reach of children. If accidental consumption is suspected, seek medical attention immediately.

! If the fluid comes into contact with the skin or eyes, rinse immediately with plenty of water.

! When travelling in territories where the water supply contains salt, always ensure you carry a supply of fresh (rain or distilled) water. Topping up with salt water will cause serious engine damage.

! The use of non-approved antifreeze will have an adverse effect on the engine cooling system and therefore engine durability.

Fluid level checks



Antifreeze will damage painted surfaces; soak up any spillage with an absorbent cloth immediately and wash the area with a mixture of car shampoo and water.

Top-up to the upper level indicator mark of the COLD FILL RANGE located on the side of the expansion tank. Use only a 50% mix of water and Castrol SF antifreeze.

The specific gravity of a 50% antifreeze solution at 20°C (68°F) is 1.068 and protects against frost down to -40°C (-40°F).

Antifreeze contains important corrosion inhibitors. The antifreeze content of the coolant must be maintained at 50% ± 5% all year round (not just in cold conditions). To ensure that the anti-corrosion properties of the coolant are retained, the antifreeze content should be checked once a year and completely renewed every ten years, regardless of distance travelled. Failure to do so may cause corrosion of the radiator and engine components.

Note: *In an emergency - and only if the approved antifreeze is unavailable - top-up the cooling system with clean water, but be aware of the resultant reduction in frost protection. Do not top-up or refill with conventional antifreeze formulations. If in doubt consult a qualified technician.*

Ensure the cap is tightened fully after top-up is completed by turning the cap until the ratchet cap clicks.

CHECKING THE BRAKE FLUID LEVEL



Brake fluid is highly toxic - keep containers sealed and out of the reach of children. If accidental consumption of fluid is suspected, seek medical attention immediately.



If the fluid comes into contact with the skin or eyes, rinse immediately with plenty of water.



Take care not to spill the fluid onto a hot engine - a fire may result.



Do not drive the vehicle with the fluid level below the MIN mark.



Seek qualified assistance immediately if brake pedal travel is unusually long or if there is any significant loss of brake fluid. Driving under such conditions could result in extended stopping distances or complete brake failure.



If the quantity of fluid in the brake reservoir drops below the recommended level, a red warning lamp in the instrument pack will illuminate.

Note: *If the warning lamp illuminates while the vehicle is being driven, stop the vehicle as soon as safety permits by gently applying the brakes. Check and top-up the fluid level if necessary.*

With the vehicle on level ground, check the fluid level at least every week (more frequently in high mileage or arduous operating conditions).

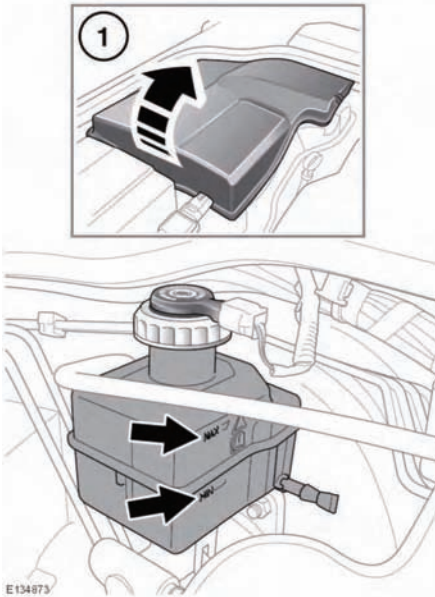

The left hand or right hand under bonnet cover must be removed (1) to check the brake fluid level, dependent on the vehicle being left-hand drive (left hand cover) or right-hand drive. See **181, UNDER BONNET COVERS - REMOVAL**.

Look at the fluid level through the side of the transparent reservoir without removing the filler cap.

The brake fluid must be between the **MAX** and **MIN** marks.

TOPPING UP THE BRAKE FLUID

- ⓘ Brake fluid will damage painted surfaces. Soak up any spillage with an absorbent cloth immediately and wash the area with a mixture of car shampoo and water.

- ⓘ Only use new fluid from an airtight container (fluid from opened containers or fluid previously bled from the system will have absorbed moisture, which will adversely affect performance, and must not be used).

1. Clean the filler cap before removing to prevent dirt from entering the reservoir.
2. Remove the filler cap.
3. Top-up the reservoir to the **MAX** mark using Shell DOT4 ESL brake fluid. If unavailable, use a low viscosity, synthetic DOT4 brake fluid that meets ISO 4925 class 6 and Land Rover LRES22BF03 specification. Only fluid of this type and standard may be used.
4. Replace the cap and reservoir cover.

POWER STEERING FLUID CHECK

- ⚠ **Power steering fluid is highly toxic. Keep containers sealed and out of reach of children. If accidental consumption of fluid is suspected, seek medical attention immediately.**
- ⚠ **If the fluid comes into contact with the skin or eyes, rinse immediately with plenty of water.**
- ⓘ Do not start the engine if the fluid level has dropped below the **MIN** mark. Severe damage to the steering pump could result.
- ⓘ Seek qualified assistance immediately if there is a noticeable drop in the fluid level. Severe damage to the steering pump could result.

Fluid level checks

- ❗ If fluid loss is slow, the reservoir may be topped-up to the upper level mark to enable the vehicle to be driven to a repair facility for examination. However, it is recommended that you seek qualified assistance before driving the vehicle.

Check and top-up the fluid with the vehicle on level ground, engine switched off, and the system cold. Ensure that the steering wheel is not turned after stopping the engine.

The level of fluid can be seen through the translucent body of the reservoir.

The fluid level should be between the **MIN** and the **MAX** marks.

TOPPING UP THE POWER STEERING FLUID

- ❗ Power steering fluid will damage painted surfaces. Soak up any spillage with an absorbent cloth immediately and wash the area with a mixture of car shampoo and water.
- ❗ Do not fill the reservoir above the **MAX** mark.

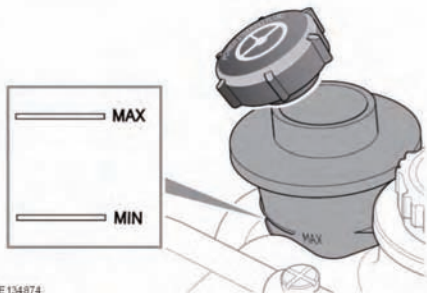

E134874

1. Clean the filler cap before removing to prevent dirt from entering the reservoir.
2. Remove filler cap.

3. Using Texaco cold climate PAS fluid, top up the reservoir until the fluid level is between the **MIN** and **MAX** marks.
4. Replace filler cap.

CHECKING THE WASHER FLUID

⚠ **Some screen washer products are inflammable, particularly if high or undiluted concentrations are exposed to sparking. Do not allow screen washer fluid to come into contact with naked flames or sources of ignition.**

⚠ **If the vehicle is operated in temperatures below 4°C (40°F), use a washer fluid with frost protection. In cold weather, failure to use a washer fluid with frost protection, could result in impaired vision and increase the risk of a vehicle crash.**

- ❗ Do not use an antifreeze or vinegar/water solution in the washer reservoir - antifreeze will damage painted surfaces, while vinegar can damage the windscreen washer pump.
- ❗ Body panels may suffer discolouration as a result of screen washer fluid spillage. Take care to avoid spillage, particularly if an undiluted or high concentration is being used. If spillage occurs, wash the affected area immediately with water.

TOPPING UP THE WASHER FLUID

The washer reservoir supplies both front and rear screen washer jets and headlamp washer jets.

Check and top-up the reservoir level at least every week. Always top-up with screen washer fluid to prevent freezing.

Operate the washer switches periodically to check that the nozzles are clear and properly directed.

1. Clean the filler cap before removing to prevent dirt from entering the reservoir.
2. Remove filler cap.
3. Top-up the reservoir until the fluid is visible in the filler neck.
4. Replace filler cap.

ENGINE SPECIFICATIONS

| | 2.7 Diesel | 3.0 Diesel | V8 Petrol |
|---------------------|-----------------------|-----------------------|-----------------------|
| Capacity | 2 720 cm ³ | 2 993 cm ³ | 5 000 cm ³ |
| Firing order | 1-4-2-5-3-6 | 1-4-2-5-3-6 | 1-5-4-2-6-3-7-8 |
| Bore | 81.0 mm | 84.0 mm | 92.5 mm |
| Stroke | 88.0 mm | 90.0 mm | 93.0 mm |
| Number of cylinders | 6 | 6 | 8 |
| Compression ratio | 17.3:1 | 16:1 | 11.5:1 |

LUBRICANTS AND FLUIDS

| Part | Variant | Specification |
|------------------------|----------------------|--|
| Engine oil | Diesel vehicles | SAE 5W-30 meeting specification WSS-M2C934-B only. If unavailable, oil meeting specification ACEA:C2 can be used. |
| | V8 petrol vehicles | SAE 5W-20 meeting specification WSS-M2C925-A only. |
| Transmission oil | 6 speed transmission | Shell ATF M1375.4 |
| | 8 speed transmission | Shell ATF L12108 |
| Transfer gearbox oil | All vehicles | Shell TF 0753 |
| Front differential oil | All vehicles | Castrol SAF-XO |
| Rear differential oil | Non-locking | Castrol SAF-XO |
| Rear differential oil | Electronic Locking | Castrol SAF Carbon Mod Plus |
| Power steering fluid | All vehicles | Texaco Cold Climate PAS fluid |
| Brake fluid | All vehicles | Shell DOT4 ESL. If unavailable, a low viscosity, synthetic compatible DOT4 brake fluid that meets ISO 4925 class 6 and Land Rover LRES22BF03 requirements may be used. |
| Screen washer | All vehicles | Screen wash with frost protection |
| Coolant | All vehicles | 50% mixture of Castrol SF antifreeze and water. |

CAPACITIES

| Item | Variant | Capacity |
|-------------------------------------|--------------------------|--------------------------|
| Fuel tank (usable) | Diesel | 82 litres (18 gallons) |
| | Petrol | 86 litres (19 gallons) |
| Engine oil refill and filter change | Diesel | 5.7 litres (10 pints) |
| | V8 Petrol | 8.0 litres (14 pints) |
| Manual gearbox | All vehicles | 1.6 litres (2.8 pints) |
| Automatic gearbox | All vehicles | Filled for life |
| Transfer box | All vehicles | 1.5 litres (2.64 pints) |
| Front differential - wet fill | All vehicles | 0.56 litres (1 pints) |
| Rear differential - wet fill | Non-locking | 1.18 litres (2.08 pints) |
| Rear differential - wet fill | Electronic locking | 1.72 litres (3.03 pints) |
| Washer reservoir | 3.0 Diesel and V8 Petrol | 5.6 litres (9.8 pints) |
| | 2.7 Diesel | 6.3 litres (11 pints) |
| Cooling system (refill) | 2.7 Diesel | 16.7 litres (29.4 pints) |
| | 3.0 Diesel | 11.5 litres (20.2 pints) |
| | V8 Petrol | 17 litres (30 pints) |

The quoted capacities are approximate and provided as a guide only. All oil levels must be checked using the dipstick, level plugs, driver information module or drain and refill, as applicable.

Technical specifications

WEIGHTS

| | Metric (kg) | Imperial (lb) |
|---|-------------|---------------|
| EC kerb weights from (including full fuel tank): | | |
| 5.0 Petrol | 2 548 | 5 617 |
| 2.7 Diesel (5-seat) | 2 476 | 5 459 |
| 2.7 Diesel (7-seat) | 2 546 | 5 613 |
| 3.0 Diesel | 2 583 | 5 695 |
| Maximum Gross Vehicle Weight (GVW) ¹ : | | |
| 2.7 Diesel (5-seat, coil suspension) | 3 180 | 7 011 |
| All other vehicles | 3 240 | 7 143 |
| Gross Train Weight ² : | | |
| 2.7 Diesel (coil suspension) | 6 680 | 14 727 |
| All other vehicles | 6 740 | 14 859 |
| Maximum front axle load ³ : | | |
| All vehicles | 1 450 | 3 197 |
| Maximum rear axle load ³ : | | |
| 2.7 Diesel (5-seat, coil suspension) | 1 840 | 4 057 |
| All other vehicles | 1 855 | 4 090 |
| Maximum roof rack load ⁴ : | | |
| All vehicles | 75 | 165 |
| <p>¹ The maximum permissible weight of the vehicle including passengers and load.</p> <p>² The maximum permissible weight of the vehicle and braked trailer including their respective loads.</p> <p>³ Axle weights are non-additive. The individual maximum axle weights and Gross Vehicle Weight must not be exceeded.</p> <p>⁴ This figure includes the weight of the roof rack.</p> | | |

DIMENSIONS

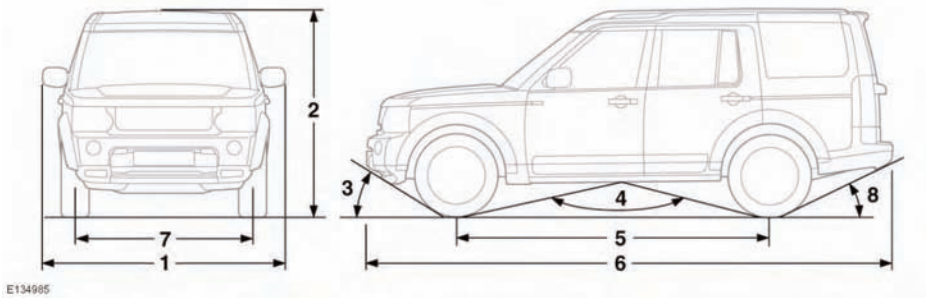

| Item | Description | mm (inches) | Degrees |
|------|---|-------------------|---------|
| 1 | Width (including mirrors) | 2176 (85.7) | - |
| 2 | Overall height | 1887 (74.3) | - |
| 3 | Approach angle (at EEC kerb weight and off-road height) | - | 31.5° |
| 4 | Ramp breakover angle (at EEC kerb weight and off-road height) | - | 135.4° |
| 5 | Wheelbase | 2885 (113.6) | - |
| 6 | Overall length | 4838 (190.5) | - |
| 7 | Track - front | 1605 (63.2) | - |
| | Track - rear | 1612.5 (63.5) | - |
| 8 | Departure angle without tow hitch (at EEC kerb weight plus full size spare tyre and at off-road height) | - | 24.9° |
| - | Departure angle with fixed height tow hitch (at EEC kerb weight) | - | 15.7° |
| - | Wading depth | 600 (23.6) | - |
| - | Minimum ground clearance | 185 (7.3) | 18.5° |
| - | Turning circle (kerb to kerb) | 11.45 m (37.5 ft) | - |
| - | Maximum gradient (nose up/down - continuous operation) | - | 35° |
| - | Maximum gradient (nose up/down - drive through) | - | 45° |

BULB SPECIFICATION



Before attempting to replace a bulb, ensure that both the affected lamp and the vehicle's ignition, are turned off. If the circuit remains live, a short circuit can occur which may damage the vehicle's electrical system.

| Lamp | Specification | Power (Watts) |
|--------------------------------------|---------------|---------------|
| Halogen headlamp (low and high beam) | H7 | 55 |
| Xenon headlamp (low and high beam) | D35 | 35 |
| Cornering lamps | H8 | 35 |
| Front side lamps | W3W | 3 |
| Front direction indicators | PY24W | 24 |
| Front fog lamps | H11 | 55 |
| Side repeater lamps | WY5W | 5 |
| Reverse lamps | P21W | 21 |
| Rear fog lamps | P21W | 21 |
| License plate lamps | W5W | 5 |
| Puddle lamps | W5W | 5 |
| Interior lamps | W5W | 5 |

WHEEL AND TYRE SIZES (Saudi Arabia and China only)

| Wheel size | Tyre size | Load index |
|------------|------------------------------------|------------|
| 5.5J x 19 | T175/80 R19 M (Temporary spare) | 122 |
| 7.0J x 17 | 235/70 R17 H | 111 |
| 8.0J x 18 | 255/60 R18 V | 112 |
| 8.0J x 19 | 255/55 R19 V | 111 |
| 8.5J x 20 | 255/50 R20 Y | 109 |

ACCESSORY WHEELS AND TYRES

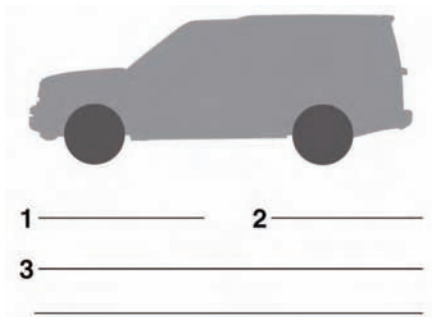

E134875

Note: Use the diagram above to record accessory wheel and tyre information.

1. Front tyre pressure.
2. Rear tyre pressure.
3. Wheel and tyre information (size, speed rating, etc.).



Contact a Dealer/Authorised Repairer before fitting any accessory wheels and tyres.

WHEEL ALIGNMENT DATA (CHINA)

| | |
|-------------------------|----------------|
| Wheel alignment - front | +0.16° ± 0.2° |
| Wheel alignment - rear | 0.24° ± 0.14° |
| Camber - front left | -0.15° ± 0.75° |
| Camber - front right | -0.5° ± 0.75° |
| Camber - rear left | -0.75° ± 0.75° |
| Camber - rear right | -0.75° ± 0.75° |
| Castor - front left | 3.86° ± 0.75° |
| Castor - front right | 4.17° ± 0.75° |

BRAKE PEDAL TRAVEL (CHINA)

The brake pedal travel is set at the factory and is non-adjustable.

REMOTE KEY FOB TRANSMITTER LOCATIONS

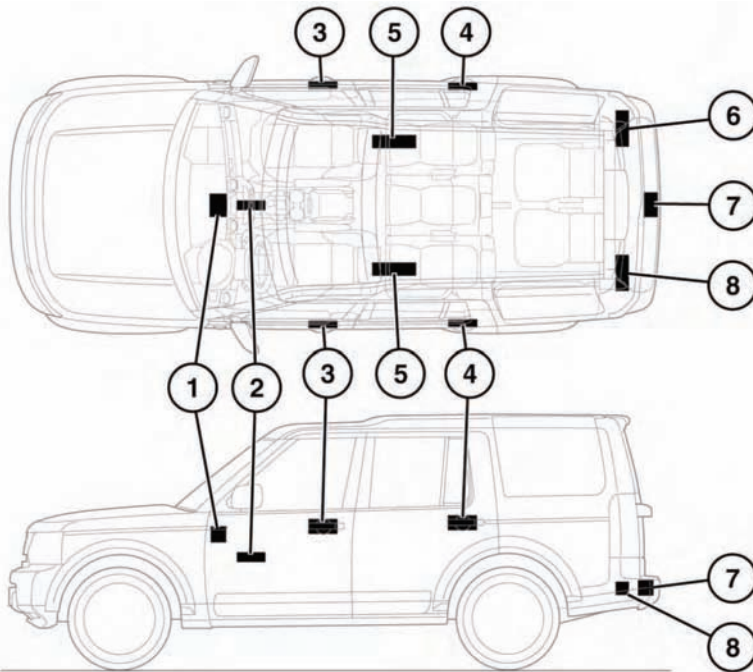

E134876

1. Cabin front transmitter.
2. Keyless start module.
3. Front exterior door handle transmitters.
4. Rear exterior door handle transmitters.
5. Cabin headlining transmitter.
6. Right-hand side loadspace transmitter.
7. Luggage compartment.
8. Left-hand side loadspace transmitter.



Any person fitted with an implanted medical device should ensure that the device is kept at a distance of at least 22 cm (8.7 inches) away from any transmitter mounted in the vehicle. This is to avoid any possibility of interference between the system and the device.

BATTERY WARNING SYMBOLS



Do not allow naked flames or other sources of ignition near the battery, as the battery may emit explosive gases.



Ensure that when working near or handling the battery, suitable eye protection is worn, to protect the eyes from acid splashes.



To prevent risk of injury, do not allow children near the battery.



Be aware that the battery may emit explosive gases.



The battery contains acid which is extremely corrosive and toxic.



Consult the handbook for information, before handling the battery.

BATTERY CARE



Do not allow the battery electrolyte (fluid) come into contact with your skin or eyes. It is both corrosive and toxic, and the resulting injuries can be severe. If any electrolyte does come into contact with your skin or eyes, immediately rinse the affected area with clean, cold water. Immediate medical advice will be required.



If battery electrolyte comes into contact with your skin and/or clothes you should remove the affected clothing and flush the skin with copious amounts of water. Seek medical assistance immediately.



If battery electrolyte comes into contact with your eyes, flush with copious amounts of clean cold water. Seek medical assistance immediately, and continue to flush with water.



If swallowed, battery electrolyte can be fatal. If electrolyte is swallowed seek medical assistance immediately.



Do not connect any 12 volt equipment directly to the battery terminals. Doing so may cause a spark, which can result in an explosion.



The cell plugs and vent pipe must be in place at all times when the battery is connected to the vehicle. Ensure that the vent pipe is clear of obstructions and not kinked. Failure to do so may cause a pressure build up in the battery, resulting in an explosion.



Do not expose the battery to a naked flame or spark as the battery produces explosive, flammable gas.



Never jump start (boost) or charge, a frozen battery. Doing so can result in an explosion.



Remove all metal jewellery before working on, or near, the battery, and never allow metal objects or vehicle components to come into contact with the battery terminals. Metal objects can cause sparks, and/or short circuits, resulting in an explosion.



Do not allow the battery posts or terminals to come into contact with your skin. They contain lead, and lead compounds which are toxic. Always wash your hands thoroughly after handling the battery.

Vehicle battery

Your vehicle is fitted with a low maintenance battery.

In hot climates more frequent checks of the battery electrolyte level and condition are required. If necessary, the battery cells can be topped up using distilled water.

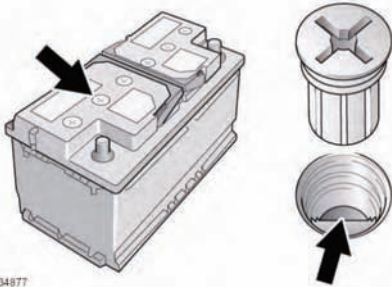

E134877

Unscrew the six cell plugs and store carefully.

Check that the surface of the liquid (electrolyte) is level with the plastic level indicator. If necessary, top up with distilled water, but never overfill. Refit the six cell plugs.

CONNECTING BOOSTER CABLES



Rotating parts of the engine can cause serious injury. Take extreme care when working near rotating parts of the engine.



Before attempting to start the disabled vehicle, make sure that the parking brake is applied, or suitably chock the wheels. Make sure that Park is selected or the manual gearbox is in neutral.



Suitable eye protection must be worn when working in the area of the battery.



Do not attempt to start the disabled vehicle if it is suspected that the electrolyte in the battery is frozen.



During normal use, batteries emit explosive gas sufficient to cause severe explosions and capable of causing serious injury - keep sparks and naked lights away from the engine compartment.



Make sure there is no physical contact between the donor and disabled vehicles other than the booster cables.



Make sure that the slave battery or starting aid is a 12 volt device.



Disconnect the battery cables prior to operating any electrical equipment.

Note: Before connecting booster cables ensure that the battery connections on the disabled vehicle are correct, and that all electrical equipment has been switched off.

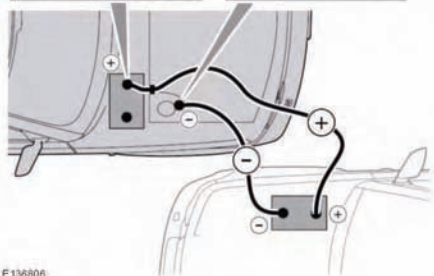
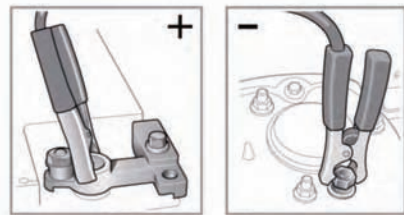

E136808

1. Connect one end of the positive (Red) booster cable to the positive terminal on the donor vehicle's battery.
2. Connect the other end of the positive booster cable to the positive terminal on the disabled vehicle's battery.

3. Connect one end of the negative (Black) booster cable to the negative terminal on the donor vehicle's battery.
4. Connect the other end of the negative booster cable to a suitable earth point on the disabled vehicle. The earth point should be at least 0.5 metres (20 inches) away from the battery, and as far as possible from any fuel or brake pipes.

Note: Check that all cables are clear of any moving components, and that all four connections are secure.

5. Start the engine of the donor vehicle, and allow it to idle for a few minutes.
6. Start the engine of the disabled vehicle.
Note: Do not switch on any electrical circuits on the previously disabled vehicle until after the booster cables have been removed.
7. Allow both vehicles to idle for a few minutes.
8. Switch off the donor vehicle.
9. Disconnect the negative (Black) booster cable from the previously disabled vehicle.
10. Disconnect the negative (Black) booster cable from the battery of the donor vehicle.
11. Disconnect the positive (Red) booster cable from the previously disabled vehicle.
12. Disconnect the positive (Red) booster cable from the donor vehicle.

CONNECTING A STARTING AID

To start the vehicle using a starting aid or a slave battery, follow the instructions in the sequence given.

1. Connect the positive (Red) booster cable to the positive battery terminal of the disabled vehicle.
2. Connect the negative (Black) booster cable to the ground (-) terminal of the battery.

3. Start the engine and allow it to idle.
4. Disconnect the negative (Black) booster cable from the battery terminal of the vehicle.
5. Disconnect the positive (Red) booster cable from the battery terminal of the vehicle.

REMOVING THE VEHICLE BATTERY



Switch the ignition off before disconnecting battery terminals. Always disconnect the negative terminal first and reconnect last.



Use caution when lifting the battery out of, or into, the vehicle. It is heavy, and may cause injury when lifting, or if dropped.



Do not tip the battery when lifting or moving as tilting the battery more than 45 degrees may damage the battery, and may cause the electrolyte to leak out. Battery electrolyte is highly corrosive, and toxic.



Do not rest the battery on any part of the vehicle as it may cause damage due to its weight.



Do not run the engine with the battery disconnected. Doing so may damage the charging system.

1. Ensure that all electrical circuits are switched off, all windows are closed, and the alarm is disarmed.
2. Remove the remote control from the vehicle and wait two minutes to allow the systems to power down fully.
3. Undo the negative clamp, and lift the cable and clamp clear of the battery terminal.
4. Undo the positive clamp, and lift the cable and clamp clear of the battery terminal.

Vehicle battery

5. Undo the battery clamp and lift the battery clear of the vehicle.

EFFECTS OF DISCONNECTING

Disconnecting the battery can affect a number of vehicle systems, especially if there is insufficient battery power prior to disconnection. For example, the alarm may trigger depending on it's state when the battery was disconnected. If the alarm does sound, use the remote control in the normal way to disarm the security system. The windows may need recalibrating to operate correctly.

CHARGING THE VEHICLE BATTERY



Ensure that the correct type and rating of charger used. Using an unsuitable charger may damage the battery, and could cause the battery to explode.



Always charge the battery in a well ventilated area away from any naked flames, sparks or other ignition sources. During charging the battery can produce a highly explosive and flammable gas.



The battery must be disconnected and removed from the vehicle before charging. Failure to do so could result in damage to the vehicle's electrical system.



Always follow the instructions supplied with the battery charger. Failure to do so may result in damage to the battery.

1. Disconnect the battery and remove it from the vehicle.
2. Connect the battery charger in accordance with the charger manufacturer's instructions.
3. Once the charge is complete switch off the power to the charger.





4. Disconnect the charger cables from the battery.
5. Allow the battery to stand for an hour before connecting to the vehicle. This will allow any explosive gasses to dissipate, and reduce the risk of explosion.

REPLACING THE VEHICLE BATTERY



Only fit a battery of the correct type and rating. Fitting an incorrect battery may result in a fire, or damage to the electrical system. If you are in any doubt when fitting a battery seek qualified assistance.



TYRE CARE

-  Do not drive the vehicle if a tyre is damaged, excessively worn, or incorrectly inflated.
-  Avoid contaminating the tyres with vehicle fluids as they may cause damage to the tyre.
-  Avoid spinning the wheels. The forces released can damage the structure of the tyre, and cause it to fail.
-  If wheel spin is unavoidable due to a loss of traction (in deep snow for example), do not exceed the 50 km/h (30 mph) point on the speedometer.

Note: Tyre condition should be checked after the vehicle has been used off-road. As soon as the vehicle returns to a normal, hard, road surface, stop and check for tyre damage.

All of the vehicle's tyres (including the spare) should be checked regularly for damage, wear and distortion. If you are in any doubt about the condition of a tyre, have it checked immediately by a tyre repair centre of your Dealer/Authorised Repairer.

TYRE PRESSURES

-  Never drive your vehicle if the tyre pressures are incorrect.
-  Pressure checks should only be carried out when the tyres are cold, and the vehicle has been stationary for more than three hours. A hot tyre at, or below, recommended cold inflation pressure, is dangerously under-inflated.
-  If the vehicle has been parked in strong sunlight, or used in high ambient temperatures, do not reduce the tyre pressures. Move the vehicle into the shade and allow the tyres to cool before rechecking the pressures.

CHECKING THE TYRE PRESSURES

The recommended tyre pressures are listed on a label located in the driver's door opening.

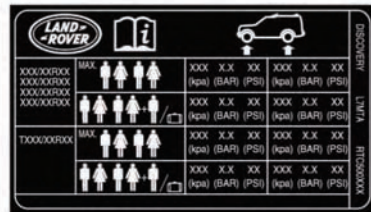

| | | | | | |
|------------|---------|---------|---------|----------|---------|
| LAND ROVER | | i | | Car icon | |
| XXX XXX | XXX XXX | XXX XXX | XXX XXX | XXX XXX | XXX XXX |
| (kPa) | (BAR) | (PSI) | (kPa) | (BAR) | (PSI) |
| XXX XXX | XXX XXX | XXX XXX | XXX XXX | XXX XXX | XXX XXX |
| (kPa) | (BAR) | (PSI) | (kPa) | (BAR) | (PSI) |
| MAX | | XXX XXX | | XXX XXX | |
| XXX XXX | | (kPa) | | (BAR) | |
| (PSI) | | XXX XXX | | XXX XXX | |
| (kPa) | | (BAR) | | (PSI) | |

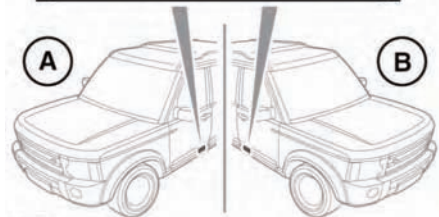

E134876

- A. Tyre information label location on a left-hand drive vehicle.
- B. Tyre information label location on a right-hand drive vehicle.

-  Tyre pressures should be checked regularly using an accurate pressure gauge, when the tyres are cold.

The following procedure should be used to check and adjust a tyre pressure.

1. Remove the valve cap.
2. Firmly attach a tyre pressure gauge/inflator to the valve.
3. Read the tyre pressure from the gauge and add air if required.
4. If air is added to the tyre, remove the gauge and re-attach it before reading the pressure. Failure to do so may result in an inaccurate reading.

5. If the tyre pressure is too high, remove the gauge and allow air out of the tyre by pressing the centre of the valve. Refit the gauge to the valve and check the pressure.
6. Repeat the process, adding or removing air as required, until the correct tyre pressure is reached.
7. Refit the valve cap.

TYRE VALVES

Keep the valve caps screwed down firmly to prevent water or dirt entering the valve. Check the valves for leaks when checking the tyre pressures.

PUNCTURED TYRES



Do not drive the vehicle with a punctured tyre. Even if the punctured tyre has not deflated, it is unsafe to use, as the tyre may deflate suddenly at any time.

REPLACEMENT TYRES



Always fit replacement tyres of the same type, and wherever possible, of the same make and tread pattern.



If the use of tyres not recommended by Land Rover is unavoidable, ensure that you read, and fully comply with, the tyre manufacturer's instructions.

Ideally, tyres should be replaced in sets of four. If this is not possible, replace the tyres in pairs (both front or both rear). When tyres are replaced, the wheels should always be re-balanced and alignment checked.

The correct tyre specification for your vehicle can be found on the tyre information label. See **211, CHECKING THE TYRE PRESSURES**.

AVOIDING FLAT SPOTS

In order to minimise flat spotting if your vehicle is parked for a long period of time. The tyre pressures can be increased to the maximum as stated on the tyre sidewall, for the period when the vehicle is stationary. Tyres must be returned to the specified running pressures before driving.

TYRE DEGRADATION

Tyres degrade over time due to the effects of ultraviolet light, extreme temperatures, high loads, and environmental conditions. It is recommended that tyres are replaced at least every six years, but they may require replacement more frequently.

USING WINTER TYRES

M+S (mud and snow) marking on the tyre sidewall indicates an 'all season' tyre designed for use all year round, including cold temperatures, snow and ice.



This symbol identifies dedicated winter tyres, which can be fitted if optimum winter traction is required, or the vehicle is to be used in more extreme winter conditions.

Note that the dedicated winter tyre often has a lower speed rating than the original equipment tyre, and the vehicle must therefore be driven within the speed limitation of the tyre.

The tyre pressures indicated on the tyre information label are for use in all conditions on the original equipment tyres. If a reduced speed rating tyre is fitted, the recommended pressures are only suitable for use below 160 km/h (100 mph).

For optimum traction, tyres should be run in for at least 160 kilometres (100 miles) on dry roads prior to driving on snow or ice.

Recommended winter tyres are identified in the following table:

| Approved winter tyres | |
|-----------------------|--|
| 18 inch wheels | 235/65 R18 110H Dunlop Winter Sport M3 |
| 19 inch wheels | 255/55 R19 111V Goodyear Ultra Grip |
| 20 inch wheels | 255/50 R20 109V Continental Cross Contact Winter |

USING SNOW CHAINS



Only use traction devices in heavy snow conditions, on hard road surfaces.



Dynamic Stability Control (DSC) must be switched off when using traction devices.



Never exceed 50 km/h (30 mph) when traction devices are fitted.



Never fit traction devices to a temporary use spare wheel.

Land Rover approved traction devices may be used to improve traction on a hard road surface in heavy snow conditions. They should not be used in off-road conditions.

If it becomes necessary to fit traction devices, the following points must be observed:

- No traction devices should be fitted to the rear wheels.
- Single sided spikes-spider traction devices can be fitted to the front wheels of vehicles fitted with 18, 19 or 20 inch diameter wheels.
- The wheels and tyres fitted must conform to the specifications of the original equipment.
- Only Land Rover approved traction devices should be used on the vehicle. Only Land Rover approved traction devices have been tested to ensure that they do not cause damage to the vehicle. Contact a Dealer/Authorised Repairer for information.
- Always read, understand and follow the traction device manufacturer's instructions. Pay particular attention to the recommended maximum speed and the traction device fitting instructions.
- Avoid tyre/vehicle damage, by removing the traction devices as soon as the conditions allow.

FUSE BOX LOCATIONS

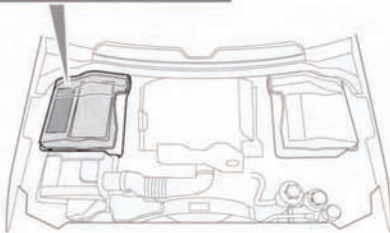
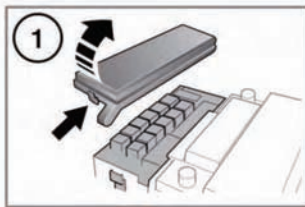

E135171

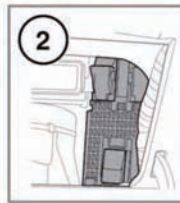

1. Engine compartment fuse box.
2. Passenger compartment fuse box.

To access the passenger compartment fuse box, open the glovebox, pinch the top of the support stays and lower the glovebox into the footwell.

A label on the rear of the glovebox shows the circuits protected and the fuse locations.

The engine compartment fuse numbers and positions are shown on the inside of the fuse box cover.

Note: Land Rover recommend that relays should only be replaced by qualified persons.

Always switch off the ignition, and the affected electrical circuit, before replacing a fuse.

CHANGING A FUSE

- ⚠ Fit Land Rover approved replacement fuses of the same rating and type, or fuses of matching specification. Using an incorrect fuse, may result in damage to the vehicle's electrical system and can result in a fire.
- ⚠ If the replacement fuse blows after installation, the system should be checked by your Land Rover Dealer/Authorised Repairer.

ENGINE COMPARTMENT FUSE BOX

| Fuse number | Rating (Amps) | Fuse colour | Circuits protected |
|-------------|---------------|-------------|--|
| 1 | 25 | White | Fuel pump |
| 2 | 5 | Tan | Petrol - EMS (MAGF, oil sensor). Diesel - fuel burning heater. |
| 3 | 5 | Tan | Air suspension ECU |
| 4 | 25 | White | EMS (ECM, fuel pump relay control) |
| 5 | 15 | Blue | EMS |
| 6 | 15 | Blue | Petrol - EMS (ignition coils). Diesel - EMS (sensors, glow plug relay control) |
| 7 | - | - | - |
| 8 | 25 | White | Rear seat heater |
| 9 | - | - | - |
| 10 | 10 | Red | Petrol - EMS (throttle motor). Diesel - EMS |
| 11 | 15 | Blue | Petrol - EMS (oxygen sensors). Diesel 3.0 - A/C compressor clutch |
| 12 | 10 | Red | Heated washer jets |
| 13 | 15 | Blue | EMS |
| 14 | 15 | Blue | Petrol - EMS (oxygen sensors) |
| 15 | 30 | Green | Heated front screen |
| 16 | 15 | Blue | Rear wiper |
| 17 | 10 | Red | Diesel 3.0 - EMS (MAF, EGR) |
| 18 | 30 | Green | Headlamp power wash |
| 19 | - | - | - |
| 20 | 5 | Tan | Alternator |
| 21 | 5 | Tan | Dynamic stability control (DSC), Anti-lock braking system (ABS) |
| 22 | 30 | Green | Rear blower |
| 23 | 25 | White | Traction control |
| 24 | 25 | White | Front seat heaters |
| 25 | 15 | Blue | Horn |
| 26 | 20 | Yellow | Air suspension ECU |
| 27 | 5 | Tan | Engine control module (ECM) |

Fuses

| Fuse number | Rating (Amps) | Fuse colour | Circuits protected |
|-------------|---------------|-------------|--|
| 28 | 20 | Yellow | Petrol V8 SC - intercooler water pump. Diesel - auxiliary heater |
| 29 | 30 | Green | Front wipers |
| 30 | 10 | Red | Auto transmission ECU |

PASSENGER COMPARTMENT FUSE BOX

| Fuse number | Rating (Amps) | Fuse colour | Circuits protected |
|-------------|---------------|-------------|---|
| 1 | 5 | Tan | Radio frequency receiver, TPM system |
| 2 | - | - | - |
| 3 | 15 | Blue | Front fog lamps |
| 4 | 5 | Tan | Automatic dimming interior mirror |
| 5 | 5 | Tan | Dynamic stability control (DSC), Anti-lock braking system (ABS), steering angle sensor |
| 6 | - | - | - |
| 7 | - | - | - |
| 8 | - | - | - |
| 9 | 5 | Tan | Electric parking brake (EPB) |
| 10 | 5 | Tan | Air suspension ECU |
| 11 | 10 | Red | Trailer reverse lamp |
| 12 | 5 | Tan | Reverse lamps |
| 13 | - | - | - |
| 14 | 5 | Tan | Brake lamps, brake switch |
| 15 | 30 | Green | Heated rear window |
| 16 | 10 | Red | Cubby box cooler |
| 17 | 5 | Tan | Keyless entry/start, central door locking |
| 18 | - | - | - |
| 19 | 5 | Tan | Engine control module (ECM) |
| 20 | 10 | Red | Heated steering wheel |
| 21 | 10 | Red | Centre console switches (transfer box, HDC, DSC), headlamp levelling, rear climate control, smog sensor |
| 22 | 5 | Tan | Automatic transmission, transfer box, rear differential |













| Fuse number | Rating (Amps) | Fuse colour | Circuits protected |
|-------------|---------------|-------------|---|
| 23 | 5 | Tan | Headlamp levelling |
| 24 | 10 | Red | Right-hand side lamps, tail lamps |
| 25 | 10 | Red | Left-hand side lamps, tail lamps |
| 26 | - | - | - |
| 27 | 10 | Red | Trailer side lamps |
| 28 | - | - | - |
| 29 | - | - | - |
| 30 | 25 | White | Front passenger window, central door locking |
| 31 | 5 | Tan | Rain sensor, rear view camera |
| 32 | 25 | White | Driver's window, exterior mirrors, central door locking |
| 33 | - | - | - |
| 34 | 10 | red | Electric fuel flap actuator |
| 35 | - | - | - |
| 36 | 5 | Tan | Battery back-up sounder |
| 37 | 20 | Yellow | Keyless entry, central door locking |
| 38 | 15 | Blue | Front screen washer |
| 39 | 25 | White | Rear left-hand window, central door locking |
| 40 | 5 | Tan | Seat memory, clock, driver's door switch pack (exterior mirrors, windows) |
| 41 | 5 | Tan | Power amplifier |
| 42 | 30 | Green | Driver's electric seat |
| 43 | 15 | Blue | Rear screen washer |
| 44 | 25 | White | Rear right-hand window, central door locking |
| 45 | 30 | Green | Passenger electric seat |
| 46 | - | - | - |
| 47 | 20 | Yellow | Sunroof |
| 48 | 30 | Green | Trailer connector (battery feed) |
| 49 | 5 | Tan | Adaptive front lighting (right-hand unit) |
| 50 | 5 | Tan | Adaptive front lighting (left-hand unit) |
| 51 | 5 | Tan | Steering wheel switches |
| 52 | - | - | - |
| 53 | 20 | Yellow | Cigar lighter |

Fuses

| Fuse number | Rating (Amps) | Fuse colour | Circuits protected |
|-------------|---------------|-------------|---|
| 54 | 15 | Blue | Trailer connector (ignition feed) |
| 55 | 20 | Yellow | Auxiliary power socket - centre and rear |
| 56 | 10 | Red | Airbag SRS |
| 57 | 10 | Red | Interior lamps |
| 58 | - | - | - |
| 59 | - | - | - |
| 60 | - | - | - |
| 61 | 10 | Red | Instrument pack, message centre |
| 62 | 10 | Red | Climate control ECU |
| 63 | 20 | Yellow | Auxiliary power socket |
| 64 | 15 | Blue | Audio unit |
| 65 | 5 | Tan | Surround camera system |
| 66 | 5 | Tan | Diagnostic socket |
| 67 | 10 | Red | Rear seat entertainment module |
| 68 | 5 | Tan | Touch screen display, multi-media module, radio |
| 69 | 15 | Blue | IAM, HLDF, CD |

WHEEL CHANGING SAFETY

Before raising the vehicle or changing a wheel, ensure that you read and comply with the following warnings.

-  Always find a safe place to stop, off the highway and away from traffic.
-  Ensure that the vehicle and jack are both on firm level ground.
-  Apply the parking brake and engage Park (P).
-  Ensure the air suspension is set to off-road height.
-  Switch on the hazard warning lamps.
-  Ensure that the front wheels are in the straight ahead position, and engage the steering lock.
-  Disconnect trailer/caravan from vehicle.
-  Ensure that all passengers, and animals, are out of the vehicle and in a safe place away from the highway.
-  Place a warning triangle at a suitable distance behind the vehicle, facing towards oncoming traffic.
-  Remove the spare wheel prior to jacking the vehicle, to avoid destabilising the vehicle when raised.
-  Never place anything between the jack and the ground, or the jack and the vehicle.
-  **WARNING - THAT NO PERSON SHOULD PLACE ANY PORTION OF THEIR BODY UNDER A VEHICLE THAT IS SUPPORTED BY A JACK.**
-  Take care when loosening the wheel nuts. The wheel brace may slip off if not properly attached and the wheel nuts may give way suddenly. Either unexpected movement, may cause an injury.



Take care when lifting the spare wheel, and removing the punctured wheel. The wheels are heavy, and can cause injuries if not handled correctly.

TOOL KIT

Note: Tool types and positions may vary from the illustrations.

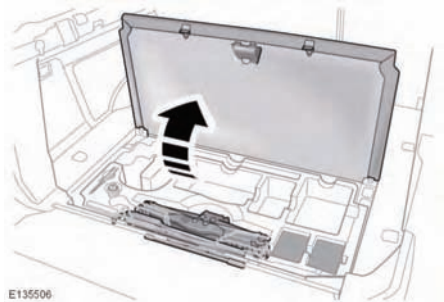

5-seat vehicles: The tool kit is located under a panel set in the loadspace floor.

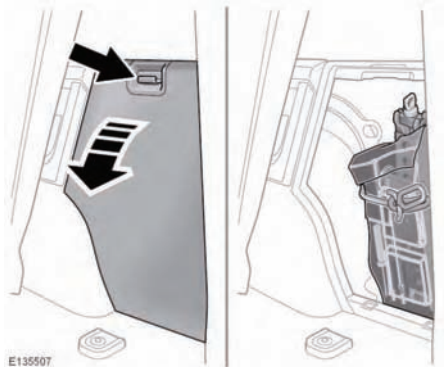

7-seat vehicles: The tool kit is stowed behind an access cover in the loadspace area.

Note: Take careful note of the stowage position for each tool, as it is important to return them to their correct position after use.

Wheel changing

REMOVING THE SPARE WHEEL

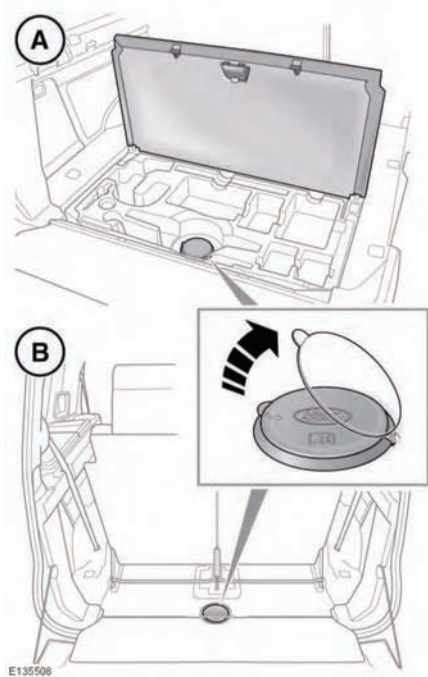

Remove the spare wheel prior to jacking the vehicle, to avoid destabilising the vehicle when raised.



Wheels are heavy and if handled incorrectly may cause injury. Use extreme caution when lifting or manoeuvring the wheels.



Always secure the spare wheel, or the removed wheel, in the correct position using the retaining bolt.

Always remove the spare wheel before jacking the vehicle. On 5 seat vehicles (A) the spare wheel lowering winch is under the rear loadspace floor. On 7 seat vehicles (B) the winch is directly under a cover behind the 3rd row seats.

- ⚠ Do not use power tools to lower the spare wheel. Doing so may damage the mechanism.

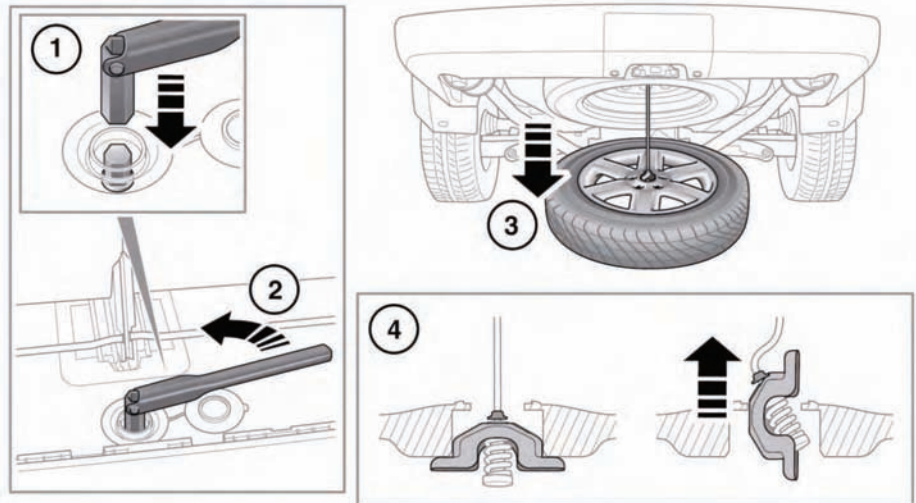

E135174

Note: Before removing the spare wheel, take note of its stowage position. The wheel to be changed must be correctly stowed in its place.

Open the spare wheel access hatch in the loadspace area. On 5 seat vehicles - remove the vehicle jack from the tool tray.

1. Lift the cap covering the spare wheel hoist winch nut and fit the wheel nut brace to the nut.
2. Rotate anticlockwise to lower the spare wheel.
3. Continue to turn the wheel hoist winch nut, until the wheel is on the ground and the hoist cable is slack. Do not attempt to turn the winch nut past its physical stop.
4. Hold the cable and tilt the lifting lug until it can be passed through the hole in the wheel, as shown.

Wheel changing

USING WHEEL CHOCKS



Always chock the wheels using suitable wheel chocks. Place the chocks on both sides of the wheel diagonally opposite the wheel to be changed.



If jacking the vehicle on a slight slope is unavoidable, place the chocks on the downhill side of both wheels on the axle not being raised.

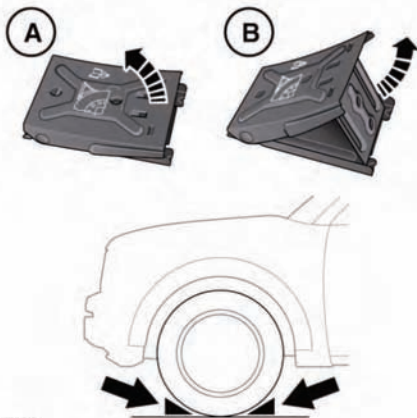

E135175

Wheel chocks are stowed in the tool kit.

1. Remove the chocks from the tool kit and lift the folded section (A) to assemble chock.
2. Lift support section (B) of chock until it locks into place.
3. Position the vehicle on level ground.
Both chocks must be used. Position them on opposite sides of the wheel and fully push them home against the tyre.

JACKING POINTS AND JACK TYPE - AIR SUSPENSION





Only jack the vehicle using the jacking points described, or damage to the vehicle could occur.

Note: Your vehicle may be fitted with a tilt sensor which activates the alarm if the vehicle is tilted in any direction after it has been locked. To lock the doors while changing the wheel, and avoid the alarm activating, turn off the alarm sensors in the vehicle set-up menu. See 52, **INTERACTIVE CONTROLS**.

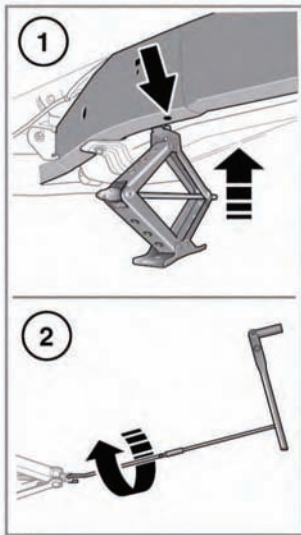
OPERATING THE JACK - AIR SUSPENSION





E135321

-  **WARNING - THAT NO PERSON SHOULD PLACE ANY PORTION OF THEIR BODY UNDER A VEHICLE THAT IS SUPPORTED BY A JACK.**
-  **WARNING - DO NOT GET UNDER A VEHICLE THAT IS SUPPORTED BY A JACK.**

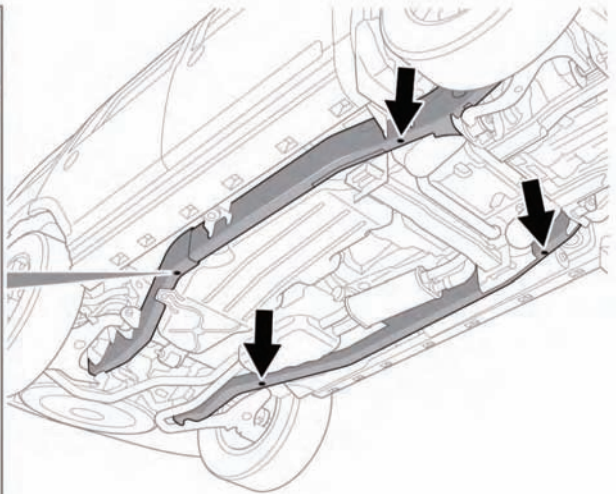
1. Locate the jack under the recommended jacking point.
2. Attach the cranking lever to the jack using the adaptor. Fit the wheel nut brace to the end of the cranking lever and rotate clockwise to raise the vehicle.



JACKING POINTS AND JACK TYPE - COIL SUSPENSION

-  Due to the nature of coil suspension systems, it is not possible to raise the wheel clear of the road surface by jacking under the chassis.
-  Only jack the vehicle using the jacking points described, or damage to the vehicle could occur.

Note: Your vehicle may be fitted with a tilt sensor which activates the alarm if the vehicle is tilted in any direction after it has been locked. To lock the doors while changing the wheel, and avoid the alarm activating, turn off the alarm sensors in the vehicle set-up menu. See **52, INTERACTIVE CONTROLS.**

Wheel changing

OPERATING THE JACK - COIL SUSPENSION

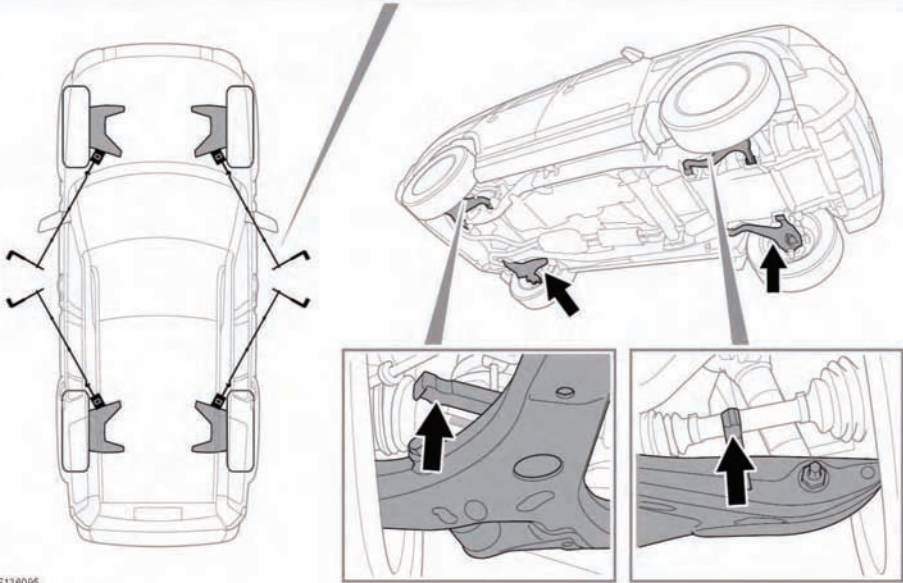
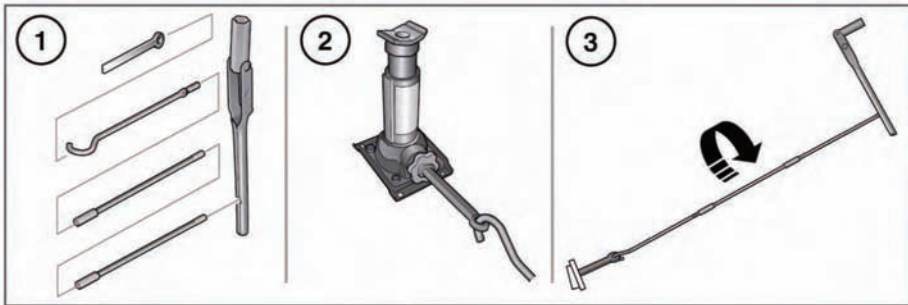

E138095



WARNING - THAT NO PERSON SHOULD PLACE ANY PORTION OF THEIR BODY UNDER A VEHICLE THAT IS SUPPORTED BY A JACK.



WARNING - DO NOT GET UNDER A VEHICLE THAT IS SUPPORTED BY A JACK.

1. Assemble the cranking lever as shown.
2. Attach the cranking lever to the jack using the adaptor.

3. Fit the wheel nut brace onto the end of the cranking lever. With the jack located under the correct jacking point, rotate the cranking lever clockwise to raise the vehicle.

LOCKING WHEEL NUTS

Locking wheel nuts can only be removed and installed using the special adapter provided in the tool kit.

Note: A code number is stamped onto the underside of the adapter. This number should be recorded on the security card supplied with the literature pack. If a replacement adapter is required, you will be asked to quote this number. The security card must be kept safe, but should not be kept with the vehicle.

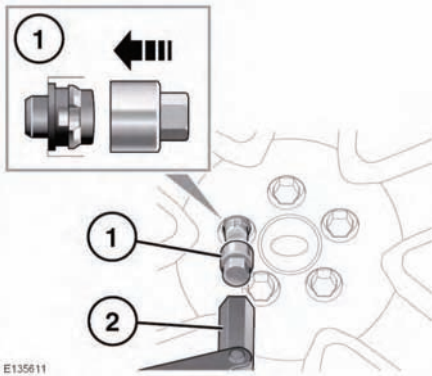

To release:

1. Insert the wheel nut adapter into the locking wheel nut, ensuring that it is fully engaged.
2. Use the wheel brace to turn the wheel nut and adapter.

Note: After use store the wheel nut adapter correctly in the tool kit.

WHEEL CHANGING

1. Read and observe the **WARNINGS** before changing a wheel, see **219, WHEEL CHANGING SAFETY**.
2. Before raising the vehicle, use the wheel nut brace to slacken the wheel nuts half a turn anticlockwise.

3. Position the jack under the relevant jacking point. For coil suspension vehicles this is located on the lower suspension arm, for air suspension vehicles this is under the chassis. Refer to the correct diagram above for your vehicle.
4. Turn the jack lever clockwise to raise the jack cradle until it engages with the jacking point. Ensure that the base of the jack is in full contact with the road surface.
5. Raise the vehicle using the jack with a slow steady operation. Avoid rapid, jerky actions as they may cause the vehicle/jack to become unstable.
6. Remove the wheel nuts and place them together where they cannot roll away.
7. Remove the wheel and place to one side. Do not lay the wheel on its face, as this may damage the finish.
8. Fit the spare wheel to the hub.
9. Re-fit the wheel nuts, and lightly tighten them. Ensure that the wheel is making contact with the hub evenly.
10. Ensure that the space under the vehicle is clear of obstructions, and lower the vehicle slowly and smoothly.
11. With all wheels on the ground and the jack removed, fully tighten the wheel nuts. The wheel nuts must be tightened in sequence (see illustration) to the correct torque of 133 Nm (98 lb.ft).

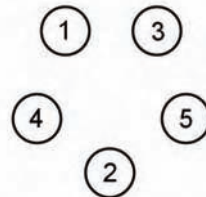

E132675

Wheel changing

Note: If it is not possible to torque the wheel nuts when a wheel is replaced, they should be set to the correct torque as soon as possible.

If an alloy spare wheel is to be fitted, using a suitable blunt tool, knock the centre cap out of the removed wheel. Using hand pressure only, press the centre cap into the newly fitted spare. Check and adjust the tyre pressure as soon as possible.



IMPORTANT - USE OF SPARE TYRE

-  Adhere to the instructions on the temporary spare warning label, affixed to the wheel.
-  Where fitted the temporary use spare wheel is **FOR TEMPORARY USE ONLY**. Drive with caution while the temporary spare wheel is fitted. Ensure that an original size wheel and tyre are fitted as soon as possible.
-  Do not fit more than one temporary spare wheel.
-  Do not exceed 80 km/h (50 mph) while the temporary spare wheel is fitted.
-  The tyre pressure in the temporary spare wheel should be 420 kPa (4.2 Bar/60 psi).
-  DSC must be switched on while the temporary spare wheel is in use.
-  Traction devices such as snow chains cannot be used with a temporary spare wheel.

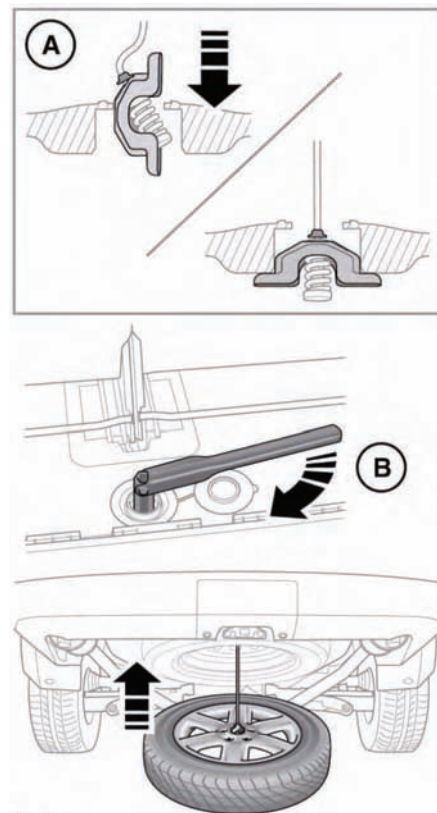
STOWING THE CHANGED WHEEL



E135176

-  Do not stow the wheel while the vehicle is raised on the jack.
-  Do not use power tools to raise the spare wheel. Doing so may damage the mechanism.

1. Place the wheel under the vehicle with the styled face uppermost.
2. Place the lifting lug through the centre of the wheel, as shown, and locate it in position (A).
3. Winch up the wheel using the wheel-hoist mechanism (B).

4. Continue to wind up, until the mechanism reaches its upper position. This is indicated by clear physical jerk from the wheel nut brace and an audible noise.
5. Check that the wheel has returned to the same position as the spare wheel was in before it was removed. If in any doubt, lower the winch slightly, adjust the wheel position and repeat step 4.



The wheel **must** be securely retained in its correct position by the winch mechanism, or it could become loose.

6. Replace the locking cap over the wheel hoist nut. As the underside of the cap is exposed to the same conditions as the underside of the vehicle, ensure that it is firmly in place.

Note: *If for any reason, the spare wheel is not to be fitted back in its hoist, the wheel hoist should be rewound as follows.*

Position the lifting lug level on the cable, and wind up the hoist mechanism until it reaches its uppermost position. This is indicated by a clear physical jerk from the wheel nut brace and an audible noise.

TOWING EYES

-  The towing eyes at the front and rear of the vehicle are designed for on-road recovery only. If they are used for any other purpose, it may result in vehicle damage and serious injury.
-  Remove the front and rear towing eye covers before driving off-road, to prevent damage or loss.

OFF-ROAD RECOVERY

-  If the towing eyes are to be used for off-road recovery, it is essential that off-road driver training covering recovery techniques is undertaken. Further information on off-road driver training can be found at <http://www.landroverexperience.com>

ATTACHING THE FRONT TOWING EYE

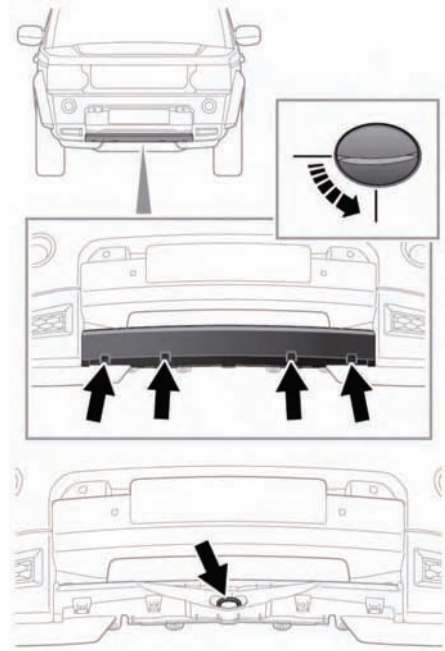

E135509

The front towing point is located behind a removable cover in the lower front bumper.

1. Rotate each of the fasteners 90 degrees anticlockwise with a coin (or similar).
2. To remove the cover, lower the top edge and then pull the cover forward.
3. To refit, offer up the cover and ensure the two lugs at the bottom edge engage with the holes in the body panel.
4. Secure the cover in position by rotating each of the fasteners 90 degrees clockwise.

REAR TOWING POINT

The rear towing point is located behind a removal panel in the lower rear bumper.

The rear towing point may be used to tow another vehicle if required.

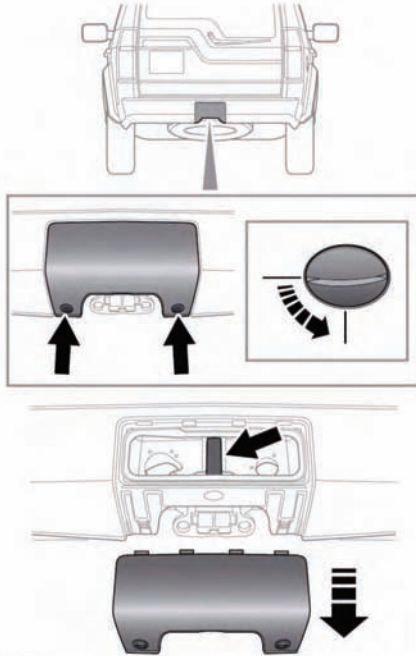

E135510

1. Rotate each of the fasteners 90 degrees anticlockwise with a coin (or similar), to release the lower edge.
2. Rotate the cover to release the hooks at the top.
3. Remove the cover.
4. To refit, position the cover in place and ensure that the four hooks on the top edge engage in the body panel.
5. Rotate the fasteners 90 degrees clockwise to secure the cover.

TOWING THE VEHICLE ON FOUR WHEELS

This procedure only applies to vehicles with a gear selector lever (6 speed transmission). On vehicles with a rotary gear selector (8 speed transmission), the transmission will automatically select P (Park) after the engine is switched off. This prevents the vehicle from being towed on all four wheels, see **81, AUTOMATIC TRANSMISSION.**



Do not remove the Smart Key from the vehicle as this will lock the steering column.



If the vehicle battery is to be disconnected, the steering column must be unlocked first. It is not possible to unlock the steering column with the battery disconnected.



If the engine cannot be used during towing, there will be no power assistance to the braking or steering systems. This will result in much greater effort to steer and stop the vehicle and in a greatly increased stopping distance.





Do not tow vehicles with a rotary gear selector (8 speed transmission) on all four wheels. Vehicle recovery should only be undertaken by suitably qualified personnel.



Only tow the vehicle in a forward direction with all four wheels on the ground. Towing in a reverse direction with two wheels on the ground, will cause serious damage to the transmission.

Vehicle recovery

-  The vehicle should only be towed for a maximum of 50 km (30 miles), at a maximum speed of 50 km/h (30 mph). Towing for a greater distance or at a higher speed, may result in serious damage to the transmission.
-  Do not tow the vehicle if the gearbox cannot be set in neutral, or the rear electronic differential has failed in the locked position.

Your vehicle has a permanent four-wheel drive system and is fitted with a steering lock. The following procedure must be carried out carefully to prevent damage to the vehicle:

1. Secure the towing attachment from the recovery vehicle to the front towing point.
2. With the parking brake applied, switch on the ignition.
3. Apply the foot brake and place the gear lever into neutral.
4. Switch off the ignition and leave the Smart Key in a secure place within the vehicle.
5. The ignition may be switched on to allow operation of indicators, brake lamps etc.
6. Release the parking brake before towing the vehicle.

-  Leaving the ignition switched on for extended periods will drain the vehicle battery.

AFTER TOWING ON FOUR WHEELS

1. Apply the parking brake.
2. Switch on the ignition and apply the foot brake.
3. Place the auto selector lever in the park position.
4. Switch off the ignition and remove the Smart Key from the vehicle.

5. Remove the towing attachment and refit the cover to the front towing point.



Use extreme caution when detaching towing equipment. Vehicle movement is possible which can result in serious injury.

BEFORE STARTING OR DRIVING



If the vehicle is involved in a collision it should be checked by a Dealer/ Authorised Repairer, or suitably qualified persons, before starting or driving.

EVENT DATA RECORDING

Event data recorders are capable of collecting and storing data during a crash or near-crash event. The recorded information may assist in the investigation of such an event. The modules may record information about both the vehicle and the occupants, potentially including such information as:

- How various systems in your vehicle were operating.
- Whether or not the driver and passenger seat belts were buckled.
- How far, if at all, the driver was pressing the accelerator and/or brake pedal.
- How fast the vehicle was travelling.
- Where the driver was positioning the steering wheel.

To access this information special equipment must be connected directly to the recording modules. Land Rover do not access event data recorder information without obtaining consent, unless pursuant to court order or where required by law enforcement, other government authorities or third parties acting with lawful authority.

Other parties may seek to access the information independently of Land Rover.

SERVICE DATA RECORDING

Service data recorders in your vehicle are capable of collecting and storing diagnostic information about your vehicle. This potentially includes information about the performance or status of various systems and modules in the vehicle such as engine, throttle, steering or brakes.

In order to properly diagnose and service your vehicle, Land Rover and service and repair facilities may access vehicle diagnostic information through a direct connection to your vehicle.

Vehicle identification

LABEL LOCATIONS



Warning labels attached to your vehicle bearing this symbol mean: Do not touch or adjust components until you have read the relevant instructions in the handbook.



Labels showing this symbol indicate that the ignition system utilises very high voltages. Do not touch any ignition components while the starter switch is turned on.

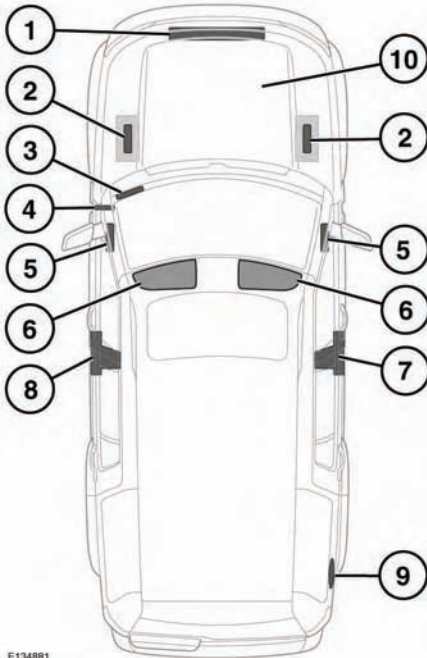

1. Bonnet locking platform - Air conditioning label.
2. Top of the battery - Battery warning symbols.

3. Top left of fascia - Vehicle Identification Number (VIN) label (China only).
4. Base of left-hand A pillar - VIN label.
5. End of the fascia (passenger side) - Passenger air bag label.
6. Sun visor - Air bag label, vehicle handling label.
7. Base of the right-hand B pillar - Tyre pressure label, air bag warning label.
Right-hand B pillar - VIN label (right-hand drive vehicles).
8. Left-hand B pillar - Air bag warning label, VIN label (left-hand drive vehicles except China).
9. Inside the fuel filler flap - Fuel label.
10. Right side of engine block or camshaft cover - Engine number.

It is important that you are familiar with these subjects to ensure that your vehicle and its features are used safely.

Note: If you need to communicate with a Dealer/Authorised Repairer, you may be asked to quote the VIN number.

VEHICLE BUILD DATE PLATE (Australia only)

This is the calendar month and year in which the body and power train assemblies were conjoined and the vehicle was driven from the production line.

The vehicle built date is shown on a tyre pressure label attached to the right-hand B pillar.

DECLARATIONS OF CONFORMITY

SIEMENS VDO
A M E R I C A N

Siemens VDO Automotive AG, P.O. Box 10 99 43, D-93059 Regensburg

Name: Dipl.-Ing. Kolar
Department: EMC Laboratory
Tel.: +49(0)941 7790-6999
Fax: +49(0)941 7790-1369999
E-Mail: dipgr.kolar@siemens.com
Internet: www.siemensvdo.de
Our Ref.: Doc_S122760002.doc
Date: 09/11/2009

Declaration of Conformity in accordance with Directive 1999/5/EC (RATTE Directive)

Manufacturer: Siemens VDO Automotive AG
Body & Chassis Electronics
Address: Siemensstrasse 12
D-93055 Regensburg
Germany
Product type designator: S122760002
Intended use: Radio frequency transmitter used Tire Pressure Monitoring system
The product mentioned above complies with the essential requirements and other relevant provisions of Directive 1999/5/EC, when used for its intended purpose:
Health and safety pursuant to §3.1.a:

Electromagnetic compatibility pursuant to § 3.1.b: Applied standard(s): EN 301 489 -1,-3,-V1.4.1 (2002-08)
Efficient use of spectrum pursuant to § 3.2: Applied standard(s): EN 300 220 -1; V1.3.1 (2000-09)

The following marking applies to the above mentioned product:



Siemens VDO Automotive AG
Regensburg, 2005-11-09

Jean-François Terabbia
Dr. Martin Fischer
Jean-François Terabbia
Executive Vice President
Body and Chassis Electronics Operations

V. Kolar
Dr. Martin Fischer
Vice President
Wireless Products and Modules

Siemens VDO Automotive AG Body & Chassis Electronics
Helmuth Mätzler
Rudolf Müller
Postal Address: Siemens VDO Automotive AG
P.O. Box 10 99 43
D-93059 Regensburg

Office Address: Siemens VDO Automotive AG
D-93055 Regensburg
Tel. +49(0)941 7790-0

Siemens VDO Automotive AG, Chairman of the Supervisory Board, Street 16, Hubland, Amberg-Weiden
Güter Heilmann, Stefan Lohrer, Johannes Müller, Christmann Regensburg, Regensburg, 09/11/2009
Page 1 of 1

SIEMENS VDO
A M E R I C A N

Siemens VDO Automotive AG, P.O. Box 10 99 43, D-93059 Regensburg

Name: Dipl.-Ing. Kolar
Department: SV-C TS R80 EMC Laboratory
Tel.: +49(0)941 7790-6999
Fax: +49(0)941 7790-1369999
E-Mail: dipgr.kolar@siemens.com
Internet: www.siemensvdo.de
Our Ref.: Doc_S122760002.doc
Date: 03/08/2005

Declaration of Conformity in accordance with Directive 1999/5/EC (RATTE Directive)

Manufacturer: Siemens VDO Automotive AG
Body & Chassis Electronics
Address: Dep. SV-C BC P2 RF TG
Siemensstrasse 12
D-93049 Regensburg
Germany
Product type designator: SWK4 9096
Intended use: Radio frequency receiver used in vehicle locking/unlocking systems
The product mentioned above complies with the essential requirements and other relevant provisions of Directive 1999/5/EC, when used for its intended purpose:
Health and safety pursuant to §3.1.a:

Electromagnetic compatibility pursuant to § 3.1.b: Applied standard(s): EN 60950-2000
Efficient use of spectrum pursuant to § 3.2: Applied standard(s): EN 301 489-1,-3,-V1.4.1 (2002-08)
EN 300 220-1; V1.3.1 (2000-09)

The following marking applies to the above mentioned product:



Siemens VDO Automotive AG
Regensburg, 2005-08-03

Jean-François Terabbia
Dr. Martin Fischer
Jean-François Terabbia
Executive Vice President
Body and Chassis Electronics Operations

V. Kolar
Dr. Martin Fischer
Vice President
Wireless Products and Modules

Siemens VDO Automotive AG Body & Chassis Electronics
Helmuth Mätzler
Rudolf Müller
Postal Address: Siemens VDO Automotive AG
P.O. Box 10 99 43
D-93059 Regensburg

Office Address: Siemens VDO Automotive AG
D-93055 Regensburg
Tel. +49(0)941 7790-0

Siemens VDO Automotive AG, Chairman of the Supervisory Board, Street 16, Hubland, Amberg-Weiden
Güter Heilmann, Stefan Lohrer, Johannes Müller, Christmann Regensburg, Regensburg, 08/11/2005
Page 1 of 1

Lear Corporation
Electronics Systems Division
21517 Telegraph Road
Warren, Michigan 48091-4218
USA
Phone (248) 447-1500



Date: February 6, 2009

INFORMATION TO BE INCLUDED IN THE END USER'S MANUAL

The following information must be included in the end product user's manual to ensure continued FCC and Industry Canada regulatory compliance. The ID numbers must be included in the manual if the device label is not readily accessible to the end user. The compliance paragraphs below must be included in the user's manual.

The following user's manual statements are provided by Lear Corporation to Jaguar Land Rover electronically after certification.

Key fobs

Land Rover, Range Rover,
 FCC ID: KOBJTF10A (Range Rover, Land Rover)
 FCC ID: KOBJTF10B (Jaguar)
 IC: 3521A-JTF10A (Range Rover, Land Rover)
 IC: 3521A-JTF10B (Jaguar)
 Model #: AH42-15X601A (Range Rover)
 Model #: AH22-15X601A (Land Rover)
 Model #: AW63-15X601A (Jaguar)

This device complies with Part 15 of the FCC Rules and with RSS-210 of Industry Canada.

Operation is subject to the following two conditions:

- (1) This device may not cause harmful interference, and
- (2) This device must accept any interference received, including interference that may cause undesired operation.

WARNING: Changes or modifications not expressly approved by the party responsible for compliance could void the user's authority to operate the equipment. The term "IC" before the radio certification number only signifies that Industry Canada technical specifications were met.

Lear Corporation
Electronics Systems Division
21517 Telegraph Road
Warren, Michigan 48091-4218
USA
Phone (248) 447-1500



RKE Receiver

Land Rover, Range Rover, Jaguar,
 FCC ID: KOBLLR09A
 IC: 3521-JLR09A
 Model #: AH42-19K602-A

This device complies with Part 15 of the FCC Rules and with RSS-210 of Industry Canada.

Operation is subject to the following two conditions:

- (1) This device may not cause harmful interference, and
- (2) This device must accept any interference received, including interference that may cause undesired operation.

WARNING: Changes or modifications not expressly approved by the party responsible for compliance could void the user's authority to operate the equipment. The term "IC" before the radio certification number only signifies that Industry Canada technical specifications were met.

Passive Entry / Passive Start Module

Land Rover, Range Rover, Jaguar,
 FCC ID: KOBIBG10A
 IC: 3521-IBG10A
 Model #: AH23-19H440 (PEPS)
 Model #: AH42-19H440 (Passive Start ONLY)
 FCC ID: KOBIBG10B
 IC: 3521-IBG10B
 Model #: AH22-19H440 (PEPS)
 Model #: AH42-19H440 (Passive Start ONLY)

This device complies with Part 15 of the FCC Rules and with RSS-210 of Industry Canada.

Operation is subject to the following two conditions:

- (1) This device may not cause harmful interference, and
- (2) This device must accept any interference received, including interference that may cause undesired operation.

WARNING: Changes or modifications not expressly approved by the party responsible for compliance could void the user's authority to operate the equipment. The term "IC" before the radio certification number only signifies that Industry Canada technical specifications were met.

EC Declaration of Conformity

EC Directive: 1999/5/EC
 Manufacturer: Lear Corporation
 Type Designation / FCC ID: KOBUBG10B
 Model Numbers: 5E0770357, 19H440, AH22-19H440, AH22-19H440-AD, AH22-19H440-AE
 Description / Intended Use: Remote Function Actuator (RFA), passive keyless entry and start system low frequency initiator
 Trademarks: Land Rover / Range Rover / Jaguar
 Applied Standards: European Commission Directive 2006/28/EC
 ETSI EN 60950
 ETSI EN 300 330
 CEPT/ERC/REC-70-03
 AS/NZS 4268
 FCC Regulations 47 CFR Part 15
 Responsible Person: Kevin Cotton
 Lear Corporation
 21557 Telegraph Road
 Southfield, Michigan 48033
 United States of America

Hereby, Lear Corporation declares that the product referenced above is in compliance with the essential requirements of Directive 1999/5/EC, on the approximation of the laws of the member states relating to Directive 1999/5/EC

Signed: 
 Kevin Cotton, Lear Corporation

Date: 27 March 2009

EC Declaration of Conformity

EC Directive: 1999/5/EC
 Manufacturer: Lear Corporation
 Type Designation / FCC ID: KOBUBG10A
 Model Numbers: 5E0770337, 19H440, AH22-19H440-AC, AH22-19H440-AD, AH22-19H440, AH22-19H440
 Description / Intended Use: Remote Function Actuator (RFA), passive keyless entry and start system low frequency initiator
 Trademarks: Land Rover / Range Rover / Jaguar
 Applied Standards: European Commission Directive 2006/28/EC
 ETSI EN 60950
 ETSI EN 300 330
 CEPT/ERC/REC-70-03
 AS/NZS 4268
 FCC Regulations 47 CFR Part 15
 Responsible Person: Kevin Cotton
 Lear Corporation
 21557 Telegraph Road
 Southfield, Michigan 48033
 United States of America

Hereby, Lear Corporation declares that the product referenced above is in compliance with the essential requirements of Directive 1999/5/EC, on the approximation of the laws of the member states relating to Directive 1999/5/EC

Signed: 
 Kevin Cotton, Lear Corporation

Date: 27 March 2009

EC Declaration of Conformity

EC Directive: 1999/5/EC
 Manufacturer: Lear Corporation
 Type Designation: 5E0760127
 Model Numbers: 5E0760127, 15K602, AH42-15K602-B, AH42-15K602-BC
 Description / Intended Use: RF Receiver (RFR), used in passive entry and passive start, remote keyless entry, and tire pressure monitoring systems
 Trademarks: Land Rover / Range Rover / Jaguar
 Applied Standards: European Commission Directive 2006/26/EC
 ETSI EN 60950
 ETSI EN 300 220
 CEPT/ERC/REC 70-03
 AS/NZS 4338
 Responsible Person: Kevin Cotton
 Lear Corporation
 21557 Telegraph Road
 Southfield, Michigan 48033
 United States of America

Herby, Lear Corporation declares that the product referenced above is in compliance with the essential requirements of Directive 1999/5/EC, on the approximation of the laws of the member states relating to Directive 1999/5/EC.

Signed: *Kevin Cotton*
 Kevin Cotton, Lear Corporation

Date: 27 March 2009

EC Declaration of Conformity

EC Directive: 1999/5/EC
 Manufacturer: Lear Corporation
 Type Designation: 15K601
 Model Numbers: 5E0850127, 5E0850127, 15K601-BB, AH42-15K601B, AH22-15K601B, AH42-15K601B, AH42-15K601-BC, AH22-15K601-BC
 Description / Intended Use: Passive Key (PK) / Customer Identification Device (CID), passive keyless entry system keyfob
 Trademarks: Land Rover / Range Rover
 Applied Standards: CEPT/ERC/REC 70-03
 ETSI EN 60950
 ETSI EN 300 220
 ETSI EN 301 489
 IEC EN 60950
 AS/NZS 4338
 Responsible Person: Kevin Cotton
 Lear Corporation
 21557 Telegraph Road
 Southfield, Michigan 48033
 United States of America

Herby, Lear Corporation declares that the product referenced above is in compliance with the essential requirements of Directive 1999/5/EC, on the approximation of the laws of the member states relating to Directive 1999/5/EC.

Signed: *Kevin Cotton*
 Kevin Cotton, Lear Corporation

Date: 28 March 2009

QuietTek

快特電波股份有限公司 低功率射頻電機型式認證證明

一、申請者：Lear Corporation
 二、製造廠商：Lear Corporation
 三、器材名稱：Range Rover / SE0B60227
 四、廠牌/型號：Range Rover / SE0B60227
 五、發射功率（電場強度）：315MHz; 84.195dBuV/m(Peak)
 六、工作頻率：315MHz



七、發證日期：98年06月02日
 八、審驗合格標號式樣：
 CCAH09LP0550TS

說明：

1. 請於上列標號式樣自製標籤，標貼於申請器材本體明顯處，如得證書或公司標列。
2. 經型式認證合格之低功率射頻電機，其型號、廠址、射頻性能如有變更，應重新申請型式認證。
3. 違反低功率電磁射頻電機管理辦法之規定，擅自使用或變更無線電頻率、電功率者，除處以罰鍰外並予以沒收或停止使用之處理。
4. 違章應負刑事或民事法律上之責任。
5. 本型式認證證明及其合格標號收據僅供證明用途，不得作為其他用途之證明，使用其合格標號，事後取得證書具有實質意義，得授權他人印用與證明型號之器材，使用其合格標號。

備註：

1. 本器材符合低功率射頻電機技術規範 LF00023.6.2節之規定。
2. 本認證係依國家通訊傳播委員會公告，頒發本型式認證證明。
3. 本器材符合月式及無線電型號如下：
Lear Corporation / N/A

QuietTek

快特電波股份有限公司 低功率射頻電機型式認證證明

一、申請者：Lear Corporation
 二、製造廠商：Lear Corporation
 三、器材名稱：RFA (Passive Start)
 四、廠牌/型號：LEAR / SE0770337
 五、發射功率（電場強度）：125KHz; 61.5dBuV/m(Average)
 六、工作頻率：125KHz



七、發證日期：98年06月02日
 八、審驗合格標號式樣：
 CCAH09LP0570TI

說明：

1. 請於上列標號式樣自製標籤，標貼於申請器材本體明顯處，如得證書或公司標列。
2. 經型式認證合格之低功率射頻電機，其型號、廠址、射頻性能如有變更，應重新申請型式認證。
3. 違反低功率電磁射頻電機管理辦法之規定，擅自使用或變更無線電頻率、電功率者，除處以罰鍰外並予以沒收或停止使用之處理。
4. 違章應負刑事或民事法律上之責任。
5. 本型式認證證明及其合格標號收據僅供證明用途，不得作為其他用途之證明，使用其合格標號，事後取得證書具有實質意義，得授權他人印用與證明型號之器材，使用其合格標號。

備註：

1. 本器材符合低功率射頻電機技術規範 LF00023.6.2節之規定。
2. 本認證係依國家通訊傳播委員會公告，頒發本型式認證證明。
3. 本器材符合月式及無線電型號如下：
Lear Corporation / N/A

인증번호인원번호 WISB-312G-VTSC-VV2D

방송통신기기인증서

Certificate of Broadcasting and Communication Equipment

인증의 종류
Certification Type
형식등록(Type Registration)

상호 또는 성명
Trade Name or Applicant
LEAR CORPORATION

기기의 명칭
Equipment Name
특정소형휴대통신기(대형이전송용 무선기기)

기본모델명
Basic Model Number
S50B40

파생모델명
Series Model Number

인증번호
Certification No.
LEB-200840

제조자/제조국가
Manufacturer/Country of Origin
Lear Automotive Electronics and Electrical/중국

형식기호
Type Identification
LARSZ-K02L433.977.0.11230.000P1D1

인증일월일
Date of Certification
2009년(Year) 07월(Month) 15일(Date)

기타
Others

위 기기는 「전기통신기본법」, 「전파법」에 따라 인증되었음을 증명합니다.
It is certified that foregoing equipment has been certificated under the Framework Act on Telecommunications and Radio Waves Act.

2009년(Year) 07월(Month) 15일(Date)



권과연구

Director General of Radio Research Laboratory
Korea Communications Commission Republic of Korea

인증번호인원번호 KC49-1210-RT41-CE0D

방송통신기기인증서

Certificate of Broadcasting and Communication Equipment

인증의 종류
Certification Type
형식등록(Type Registration)

상호 또는 성명
Trade Name or Applicant
LEAR CORPORATION

기기의 명칭
Equipment Name
대형이전송용 무선기기

기본모델명
Basic Model Number
S50BSP127

파생모델명
Series Model Number
S50BSP030960

인증번호
Certification No.
LEB-2008P127

제조자/제조국가
Manufacturer/Country of Origin
Lear Automotive Electronics and Electrical/중국

형식기호
Type Identification
LARSZ-K02L433.977.0.11230.000P1D1

인증일월일
Date of Certification
2009년(Year) 05월(Month) 28일(Date)

기타
Others

위 기기는 「전기통신기본법」, 「전파법」에 따라 인증되었음을 증명합니다.
It is certified that foregoing equipment has been certificated under the Framework Act on Telecommunications and Radio Waves Act.

2009년(Year) 05월(Month) 28일(Date)



권과연구

Director General of Radio Research Laboratory
Korea Communications Commission Republic of Korea

인증번호: 707E-C9J-1001-SULX

방송통신기기인증서

Certificate of Broadcasting and Communication Equipment

형식등록(Type Registration)

인증의 종류
Certification Type
상호 또는 식별
Trade Name or Applicant
기기의 명칭
Equipment Name

LEAR CORPORATION
러익 컴퍼윈드 부속기

585770237

기본모델명
Basic Model Number
파생모델명
Series Model Number

585770237

인증번호
Certification No.
제조처/제조국가
Manufacturer/Country of Origin

LEAR VULVA Automotive Electronics and Electrical/스웨덴

LPD-K08L0.1257A1D

형식기호
Type Identification
인증연월일
Date of Certification
기타
Others

2009년(Year) 09월(Month) 04일(Date)

위 기기는 「전기통신기본법」, 「전파법」에 따라 인증되었음을 증명합니다.
It is certified that foregoing equipment has been certificated under the Framework Act on Telecommunications and Radio Waves Act.

2009년(Year) 09월(Month) 04일(Date)

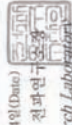

최과연

Director General of Radio Research Laboratory
Korea Communications Commission, Republic of Korea

본 인증서에는 무선주파수 사용에 관한 정보가 포함되어 있지 않습니다.

인증번호: J105-A010-084C-100T

방송통신기기인증서

Certificate of Broadcasting and Communication Equipment

형식등록(Type Registration)

인증의 종류
Certification Type
상호 또는 식별
Trade Name or Applicant
기기의 명칭
Equipment Name

LEAR CORPORATION
러익 컴퍼윈드 부속기

585770237

기본모델명
Basic Model Number
파생모델명
Series Model Number

585770237

585770237

인증번호
Certification No.
제조처/제조국가
Manufacturer/Country of Origin

LEAR VULVA Automotive Electronics and Electrical/스웨덴

LPD-K08L0.1257A1D

형식기호
Type Identification
인증연월일
Date of Certification
기타
Others

2009년(Year) 09월(Month) 04일(Date)

위 기기는 「전기통신기본법」, 「전파법」에 따라 인증되었음을 증명합니다.
It is certified that foregoing equipment has been certificated under the Framework Act on Telecommunications and Radio Waves Act.

2009년(Year) 09월(Month) 04일(Date)



최과연

Director General of Radio Research Laboratory
Korea Communications Commission, Republic of Korea

본 인증서에는 무선주파수 사용에 관한 정보가 포함되어 있지 않습니다.



Independent Communications Authority of South Africa
 Postal Box 141, Old Bree, Sandton
 Pretoria, 2008, South Africa
 Phone: +27 (0)21 5563200, 5563211, 2146

Radio Equipment Type Approval Certificate

Radio Equipment Type Approval Number

TA-2009/332

The Authority, in the exercise of the powers conferred upon it by section 33 (1) of the Electronic Communications Act, 2005 (Act 36 of 2005), the applicable radio regulations which currently remain in force in terms of section 69 (2) of the Act, as of 09 June 2009, hereby issues a radio equipment type approval certificate to the company whose name and particulars are listed below:

Company Particulars

| | |
|---------------------|---|
| Name | Jaguar Land Rover SA |
| Street Address | 1111 West Street, Silverton Road, Silverton |
| Telephone Number | 012 842 3274 |
| Facsimile Number | 012 845 1005 |
| Registration Number | 2001027268/07 |

Description of Apparatus

| | |
|-------------------|--------------------------------|
| Category | Remote Function Actuator (RFA) |
| Model | KOR-BE116A |
| Frequency Range | 119 - 135 MHz |
| ITU Emission Code | 12KGD |
| Power Output | 8PSK |
| Channel Spacing | 12.7 kHz @ 3m |
| Features | - |

Only the original or a certified copy of the radio equipment type approval certificate shall be considered valid.

Phillip Mokoabe
 Senior Manager: Engineering & Technology

09 JUN 2009

P Mokoabe (Chairperson), Ms Baine, T V Makhabe, R Haines, BB Makhabe, P G. Sibanda, Dr K M Nkomo
 Prof. J. C. van Rooyen SC, MB Zolani (Co-Chairman), BN Madisa (CEO)



Independent Communications Authority of South Africa
 Postal Box 141, Old Bree, Sandton
 Pretoria, 2008, South Africa
 Phone: +27 (0)21 5563200, 5563211, 2146

Radio Equipment Type Approval Certificate

Radio Equipment Type Approval Number

TA-2009/333

The Authority, in the exercise of the powers conferred upon it by section 33 (1) of the Electronic Communications Act, 2005 (Act 36 of 2005), the applicable radio regulations which currently remain in force in terms of section 69 (2) of the Act, as of 09 June 2009, hereby issues a radio equipment type approval certificate to the company whose name and particulars are listed below:

Company Particulars

| | |
|---------------------|---|
| Name | Jaguar Land Rover SA |
| Street Address | 1111 West Street, Silverton Road, Silverton |
| Telephone Number | 012 842 3274 |
| Facsimile Number | 012 845 1005 |
| Registration Number | 2001027268/07 |

Description of Apparatus

| | |
|-------------------|--------------------------------|
| Category | Remote Function Actuator (RFA) |
| Model | KOR-BE116A |
| Frequency Range | 119 - 135 MHz |
| ITU Emission Code | 12KGD |
| Power Output | 8PSK |
| Channel Spacing | 12.7 kHz @ 3m |
| Features | - |

Only the original or a certified copy of the radio equipment type approval certificate shall be considered valid.

Phillip Mokoabe
 Senior Manager: Engineering & Technology

09 JUN 2009

P Mokoabe (Chairperson), Ms Baine, T V Makhabe, R Haines, BB Makhabe, P G. Sibanda, Dr K M Nkomo
 Prof. J. C. van Rooyen SC, MB Zolani (Co-Chairman), BN Madisa (CEO)



Label to be used on the following products only

- citizen band radio equipment
- cellular equipment
- trunk radio equipment
- spread spectrum devices
- leased channel radio equipment
- cordless telephone
- wireless security devices
- wireless microphone
- radio-control equipment
- medical & biology telemetry equipment

- A**
- ABS (Anti-lock braking system)
 - warning lamp 56
 - Adaptive front lighting system (AFS)
 - warning lamp 56
 - AFS (Adaptive front lighting system) 39
 - Age degradation (tyres) 212
 - Air conditioning
 - air quality sensor 61
 - auto 61
 - front 60
 - rear 61
 - Air quality sensor 61
 - Airbags
 - deployment 35, 37
 - module covers 192
 - service information 37
 - SRS (Supplementary restraint system) 176
 - warning lamps 37, 56
 - Alarm 11, 176
 - deactivating 13
 - perimeter 11
 - Anchor points (ISOFIX) 31
 - Antifreeze level check 195
 - Anti-theft system 176
 - Anti-trap protection
 - windows 46
 - Arduous driving conditions 176
 - Audio
 - Settings 119
 - Audio/video
 - CD
 - controls 128
 - controls 119
 - DAB
 - reception 126
 - headphones 142
 - loading CDs 127
 - loading DVDs 139
 - MP3 127
 - portable media
 - connections 130
 - controls 132
 - pairing 134
 - play 133
 - television
 - controls 136
 - full screen 137
 - full screen controls 137
 - touch screen controls 140
 - video media player
 - controls 138
 - Auto high beam 39
 - Auto mode (climate) 61
 - Automatic gearbox 81
 - Automatic locking 9
 - Automatic reconnection (portable audio) 135
 - Auxiliary devices
 - connecting multiple devices 134
- B**
- Battery
 - boost starting 208
 - care 207
 - changing
 - timed climate remote 210
 - charging 210
 - jump starting
 - connecting cables 208
 - vehicle
 - removing 209
 - warning symbols 207
 - Beltminder
 - warning lamp 27, 55
 - Belts 192
 - safety 27
 - seatbelt warning lamp 27, 55
 - Bluetooth 148
 - audio
 - automatic reconnection 135
 - pairing 134
 - media
 - pairing 134

Index

- telephone
 - compatibility 148
 - icons 150
 - overview 147
 - pairing 149
 - phonebook 151
 - safety 148
- Bonnet
 - closing 178
 - opening 178
- Boost starting 208
- Brakes
 - ABS warning lamp 56
 - EBA (Emergency brake assist) 89
 - EBD (Electronic brake force distribution) 89
 - fluid
 - check 196
 - specification 197
 - top up 197
 - handbrake 90
 - parking brake
 - warning lamp 54
 - pedal travel 205
 - warning lamp 54
 - warning lamps 89
- Bulb replacement - interior lamps 189
- Bulbs
 - changing
 - rear lamps 187
 - license plate 188
 - number plate 188
 - specification 204
- C**
- Call volume 151
- Cameras
 - rear view 95
- Capacities 201
- CD player
 - controls 128
 - loading discs 127
- Chairs
 - child seats
 - tether straps 33
 - restricted seat travel 16
 - seatbelts 192
 - seatbelt safety 27
 - warning lamp 27, 55
 - sitting correctly 16
- Changing a bulb 181
- Changing a fuse 214
- Changing the battery (timed climate) 210
- Charging the vehicle battery 210
- Chassis number 232
- Child restraints 28
 - check list 29
 - positioning 29
- Child seats 28
 - check list 29
 - ISOFIX anchor points 31
 - positioning 29
 - tether straps 33
- Cleaning
 - exterior 190
 - interior 191
 - leather 191
 - parking sensors 95
- Climate control
 - auto 61
 - front 60
 - rear 61
 - recirculation 61
- Closing
 - single locking 11
- Closing the bonnet 178
- Column lock 78
- Condensation (headlamps) 41
- Conformity declarations 164, 233
- Consumption
 - fuel
 - urban cycle 175
- Consumption (fuel) 175

- Controls
 - headlamps 38
 - steering wheel
 - set cruise speed 96
- Coolant
 - checking the level 195
 - specification 195
 - top up 195
- Critical warning messages 54
- Cruise control
 - change speed 96
 - operating 96
 - setting vehicle speed 96
- D**
- DAB
 - ensembles 126
 - reception 126
- DAB radio
 - controls 125
- Daily checks 176
- Data recording 231
- Daylight running lamps 38
- Dealer locations 160
- Declarations of conformity 233
 - navigation system 164
- Derv
 - sulphur content 171
- Deselecting valet mode 117
- Destination entry 157
 - postcode 159
 - search area 157
 - town 160
- Dialling a number 151
- Diesel
 - engine 171
 - starting 78
 - switching off 79
 - filler flap 172
 - fuel consumption 175
 - misfuel device 174
 - specification 173
 - sulphur content 171
 - water in fuel 173
- Diesel particulate filter (DPF) 177
- Dimensions 203
- Direction indicators
 - warning lamp 56
- Disability modifications 176
- Door transceiver
 - entry gate 51
 - garage door opener 49
 - programming 49
 - programming a single button 50
 - rolling code device programming 50
- Double locking 11
- DPF (Diesel particulate filter) 177
- Drive away locking 9
- Driver controls 264
- Driver information module
 - information messages 58
 - trip computer 58
 - warning lamps 54
 - warning messages 58
- Driving
 - arduous conditions 176
 - before starting 231
 - controls 264
 - cruise control
 - change speed 96
 - set speed 96
 - daily checks 176
 - DSC warning lamp
 - active 55
 - off 55
 - EBA (Emergency brake assist) 89
 - EBD (Electronic brake force
 - distribution) 89
 - mirror dip when reversing 48
 - Position memory 17
 - sitting correctly 16
 - wipers
 - rain sensor 44
- Driving abroad
 - headlamps 40

Index

- Driving position memory 17
- DSC (Dynamic stability control)
 - switching off 85
 - switching on 85
 - warning lamp
 - active 55
 - off 55
 - warning lamps 85
- DVDs
 - loading 139
- E**
- EBA (Emergency brake assist) 89
- EBD (Electronic brake force distribution) . . 89
- Electric seats
 - front 15
- Electronic brake force distribution (EBD) . 89
- Electronic data 231
- Electronic parking brake (EPB) 90
- Engine
 - compartment
 - fuse box 215
 - opening 178
 - overview 179
 - coolant level checking 195
 - diesel 171
 - starting the engine 78
 - DPF (Diesel particulate filter) 177
 - engine compartment 179
 - failure to start 79
 - oil level check 193
 - oil specification 195
 - petrol
 - starting the engine 78
 - specifications 200
 - switching off 79
- Ensembles (DAB radio) 126
- Entering a destination 157
 - by town 160
- Entering the vehicle
 - entry and exit mode 24
 - keyless entry 8
- Entertainment
 - CD
 - controls 128
 - DAB radio
 - controls 125
 - navigation
 - all softkey 161
 - coordinates 159
 - list 161
 - menu 154
 - motorway 160
 - POI categories 160
 - POI (Points of interest) 158, 160
 - postcode 159
 - previous 159
 - restore defaults 159
 - TMC 161
 - TMC display 161
 - TMC icons 161
 - portable media
 - automatic reconnection 135
 - changing device 135
 - connecting devices 130
 - connecting multiple devices 134
 - connections 130
 - controls 132
 - lost connection 135
 - pairing 134
 - playing 133
 - radio
 - controls 123
 - RDS (Radio data system) 124
 - RSE (Rear screen entertainment)
 - screen settings 116
 - RSE (Rear seat entertainment)
 - settings 140
 - touch screen controls 140
 - telephone
 - last 10 152
 - pairing 149
 - phonebook 151
 - settings 152

- television
 - analogue/digital option 137
 - controls 136
 - full screen 137
 - full screen controls 137
- touch screen 192
 - display icons 116
 - home menu 115
 - operating 116
 - setup 116
 - system settings 116
 - touch screen care 116
- video media player
 - controls 138
- Entry and exit mode 24
- EPB (Electric parking brake) 90
- Ethanol 170
- EU conformity (navigation system) 164
- Event data recording 231
- Exiting the vehicle
 - door locks and release levers 12
 - global closing 12
 - keyless locking 12
- Exterior cleaning 190
- Exterior lamps
 - bulb changing 181
 - bulb specification 204
- Exterior mirrors 47

- F**
- Flat spots 212
- Fluids
 - brake
 - check 196
 - specification 197
 - top up 197
 - capacities 201
 - coolant
 - specification 195
 - top up 195
 - engine oil
 - check 193
 - specification 195
 - fuel tank capacity 173
 - power steering
 - check 197
 - specification 198
 - specifications 200
 - washer
 - specification 198
 - top up 198
- Fog lamps
 - warning lamp 56
- Front climate control 60
- Front parking aid 94
 - system fault 95
- Fuel and refuelling
 - consumption 175
 - extra-urban cycle 175
 - urban cycle 175
 - diesel 171
 - sulphur content 171
 - ethanol 170
 - Filler flap 172
 - filler flap 172
 - fuel consumption
 - urban cycle 175
 - fuel specification 173
 - fuel system 178
 - methanol 170
 - misfuel device 174
 - MTBE (Methyl tertiary butyl ether) 170
 - octane rating 170
 - reformulate gasoline 170
 - running out 171
 - safety precautions 170
 - tank capacity 173
 - water in fuel 173
- Full screen (television) 137
 - controls 137
- Fuses
 - changing 214
 - engine compartment fuse box 215
 - locations 214
 - Passenger compartment fuse box 216

Index

G

| | |
|-----------------------|----|
| Garage door opener | 49 |
| entry gate | 51 |
| erase all programming | 50 |
| programming | 49 |
| a single button | 50 |
| rolling code device | 50 |
| Gearbox | |
| automatic | 81 |
| Global closing | 12 |
| Global opening | 8 |

H

| | |
|---|-----|
| Hand brake | |
| warning lamp | 54 |
| Handbrake | 90 |
| Handling | |
| DSC warning lamp | |
| active | 55 |
| off | 55 |
| EBD (Electronic brake force distribution) | 89 |
| Head restraints | 22 |
| manual | 23 |
| Headlamps | |
| adaptive | 39 |
| AFS (Adaptive front lighting system) | 39 |
| auto high beam | 39 |
| bulb changing | 181 |
| bulb specification | 204 |
| condensation | 41 |
| controls | 38 |
| daylight running lamps | 38 |
| driving abroad | 40 |
| high beam warning lamp | 56 |
| warning lamp (AFS) | 56 |
| washers | 44 |
| xenon | 183 |
| Headphones | 142 |
| Heated screens | 61 |
| Heating and ventilation | |
| auto | 61 |

| | |
|---------------------------------|----|
| front | 60 |
| rear | 61 |
| recirculation | 61 |
| High beam | |
| automatic | 39 |
| warning lamp | 56 |
| Homelink | 49 |
| programming a single button | 50 |
| rolling code device programming | 50 |

I

| | |
|-----------------------------|----------|
| Ignition | |
| switching on | 78 |
| Indicators | |
| warning lamp | 56 |
| Information messages | 58 |
| Infotainment | |
| CD | |
| controls | 128 |
| DAB radio | |
| controls | 125 |
| navigation | |
| all softkey | 161 |
| coordinates | 159 |
| list | 161 |
| menu | 154 |
| motorway | 160 |
| POI categories | 160 |
| POI (Points of interest) | 158, 160 |
| postcode | 159 |
| previous | 159 |
| restore defaults | 159 |
| TMC | 161 |
| TMC display | 161 |
| TMC icons | 161 |
| portable media | |
| automatic reconnection | 135 |
| changing device | 135 |
| connecting devices | 130 |
| connecting multiple devices | 134 |
| connections | 130 |
| controls | 132 |

- lost connection 135
 - pairing 134
 - playing 133
 - radio
 - controls 123
 - RDS (Radio data system) 124
 - RSE (Rear seat entertainment)
 - screen settings 116
 - settings 140
 - touch screen controls 140
 - telephone
 - last 10 152
 - pairing 149
 - phonebook 151
 - settings 152
 - television
 - analogue/digital option 137
 - controls 136
 - full screen 137
 - full screen controls 137
 - touch screen 192
 - display icons 116
 - home menu 115
 - operating 116
 - setup 116
 - system settings 116
 - touch screen care 116
 - video media player
 - controls 138
 - Inhibited media playback 139
 - Instrument panel
 - information messages 58
 - lamp test 54
 - trip computer 58
 - warning lamps 54
 - side lights 56
 - warning messages 58
 - Interior cleaning 191
 - Interior lamps
 - bulb changing 181
 - bulb specification 204
 - Interval indicator 59
 - ISOFIX anchor points 31
- J**
- Jump starting
 - connecting cables 208
- K**
- Keyless entry 8
 - Keyless locking 12
 - Keys
 - single locking 11
- L**
- Label locations 232
 - Lamp test 54
 - Lamps
 - bulb changing 181
 - bulb specification 204
 - condensation 41
 - controls 38
 - removal
 - rear lamp 187
 - warning
 - parking brake 54
 - warning lamps 54
 - side lights 56
 - TPMS (Tyre pressure monitoring system) 57
 - xenon headlamps 183
 - Leather cleaning 191
 - License plate bulb 188
 - Lights
 - bulb changing 181
 - bulb specification 204
 - condensation 41
 - controls 38
 - List soft key (navigation) 161
 - Loading DVDs 139
 - Locking
 - door locks and release levers 12
 - double locking 11
 - drive away 9
 - global closing 12
 - keyless 12

Index

- mislock 12
- Locking and unlocking
 - alarm
 - perimeter 11
 - single locking 11
 - unlocking 5
 - Locking column 78
- Lubricants
 - specifications 200
- M**
- Main beam (auto) 39
- Maintenance
 - blocked washer jets 181
 - boost starting
 - connecting cables 208
 - brake fluid check 196
 - bulb changing 181
 - rear lamp 187
 - bulb specification 204
 - capacities 201
 - changing a fuse 214
 - checking the tyre pressures 211
 - checking the tyre pressures after a repair 168
 - cleaning parking sensors 95
 - closing the bonnet 178
 - coolant level checking 195
 - daily checks 176
 - DPF 177
 - engine compartment 179
 - exterior cleaning 190
 - interior cleaning 191
 - jump starting 208
 - label locations 232
 - leather cleaning 191
 - lubricants and fluid specifications 200
 - number plate bulb 188
 - smart key battery changing 10
 - weekly checks 176
- Manual head restraints 23
- Map (navigation system) 159
- Map split screen (navigation system) 156
- Media 139
 - inhibited 139
 - portable
 - lost connection 135
 - play 133
 - portable media
 - connections 130
- Memory points (navigation system) 159
- Message centre
 - trip computer 58
 - change display 58
 - range 59
- Methanol 170
- Mirrors
 - dip when reversing 48
- Mirrors and windows
 - exterior mirrors 47
 - sunroof
 - reset 190
- Misfuel device 174
- Modifications for disabilities 176
- Moon roof
 - reset 190
- MP3 127
- mpg 175
- MTBE (Methyl tertiary butyl ether) 170
- N**
- Navigation
 - all softkey 161
 - cancel guidance 158
 - destination entry 157
 - coordinates 159
 - emergency 159
 - motorway 160
 - postcode 159
 - previous 159
 - search area 157
 - start guidance 157
 - entering a destination town 160
 - list 161

- map 159
 - map split screen 156
 - memory points 159
 - menu 154
 - operating 153
 - overview 153
 - POI (Points of interest) 160
 - categories/sub-categories 160
 - quick POI selection 158
 - POI search 161
 - restore defaults 159
 - screen modes 156
 - TMC 161
 - display 161
 - icons 161
 - using TMC 163
 - touch screen controls 140
 - traffic event icons 162
 - voice commands (POI) 145
 - voice guidance 158
 - Number plate bulb 188
- O**
- Occupant safety
 - child seats
 - tether straps 33
 - seatbelts 192
 - seatbelt safety 27
 - warning lamp 27, 55
 - Oil
 - engine
 - level check 193
 - engine oil specification 194
 - engine oil specifications 195
 - used engine oil 178
 - One-touch operation (windows) 46
 - Opening
 - bonnet 178
- P**
- Parking aid
 - operating 94
 - rear view camera 95
 - sensor cleaning 95
 - system fault 95
 - Parking brake 90
 - warning lamp 54
 - Passenger compartment fuse box 216
 - Perimeter alarm 11
 - Petrol
 - consumption 175
 - engine
 - starting 78
 - switching off 79
 - octane rating 170
 - reformulated gasoline 170
 - specification 173
 - Petrol filler flap 172
 - Phone
 - bluetooth 148
 - call volume 151
 - changing connected phone 150
 - compatibility 148
 - controls
 - steering wheel 151
 - dialling 151
 - icons 150
 - last 10 152
 - overview 147
 - pairing using mobile phone 149
 - pairing using touch screen 149
 - phonebook 151
 - safety 148
 - settings 152
 - POI (Points of interest) 160
 - search 161
 - Portable media
 - automatic reconnection 135
 - changing device 135
 - connecting devices 130
 - connecting multiple devices 134
 - connections 130

Index

- controls 132
- lost connection 135
- pairing 134
- playing 133
- Positioning child restraints 29
- Power steering
 - fluid
 - check 197
 - specification 198
- Pressure
 - checking 211
- Pressures
 - checking
 - after a repair 168
 - tyres 211
- Previous destination (navigation system) 159
- Programming
 - garage door opener 49
 - erase all 50
- Puncture repair kit 165
 - instructions for use 167
 - repair procedure 167
 - safety 165
- Punctured tyres 212

- R**
- Radio
 - controls 123
 - DAB ensembles 126
 - DAB reception 126
 - RDS (Radio data system) 124
- Rain sensor 44
- RDS (Radio data system) 124
- RDS-TMC 161, 163
 - display 161
 - icons 161
- Rear lamp
 - bulb changing 187
 - removal 187
- Rear media
 - remote control 141
 - screen settings 116
- settings 140
- touch screen controls 140
- Reception (DAB) 126
- Recirculation 61
- Reconnection (portable audio) 135
- Recording
 - service data 231
- Recovery
 - towing eyes 228
- Reformulated gasoline 170
- Refuelling
 - diesel 171
 - sulphur content 171
 - octane rating 170
 - reformulated gasoline 170
 - running out of fuel 171
 - safety precautions 170
- Remote control
 - battery changing 10
 - Driving position memory 17
 - system transmitters 206
- Removing vehicle battery 209
- Replacement tyres 212
- Resetting the windows 190
- Restore default settings (navigation system) 159
- Restraints (child) 28, 29
 - positioning 29
- Restricted seat travel 16
- Reverse parking aid 94
 - rear view camera 95
 - system fault 95
- RSE (Rear seat entertainment)
 - operating 142
 - remote control 141
 - screen settings 116
 - settings 140
 - touch screen controls 140
- Running out of fuel 171

S

- Safety
 - fuel and refuelling 170
 - in the garage 177
 - seatbelts 27, 192
 - warning lamp 27, 55
 - sitting correctly 16
 - tyre care 211
 - used engine oil 178
 - using the telephone 148
- Satellite navigation
 - all softkey 161
 - cancel guidance 158
 - destination entry 157
 - coordinates 159
 - postcode 159
 - previous 159
 - search area 157
 - start guidance 157
 - emergency 159
 - entering a destination town 160
 - list 161
 - map 159
 - map split screen 156
 - memory points 159
 - menu 154
 - motorway 160
 - operating 153
 - overview 153
 - POI (Points of interest) 160
 - categories 160
 - quick POI selection 158
 - POI search 161
 - restore defaults 159
 - screen modes 156
 - TMC 161
 - display 161
 - icons 161
 - traffic event icons 162
 - using TMC 163
 - voice commands (POI) 145
 - voice guidance 158
- Screen modes (navigation system) 156
- Screens (heated) 61
- Search area (navigation system) 157
- Seatbelts 192
 - beltminder warning lamp 55
 - checks 27
 - safety 27
 - warning lamp 27, 55
- Seats
 - child seats
 - tether straps 33
 - Driving position memory 17
 - electric
 - front 15
 - head restraints 22
 - manual head restraints 23
 - restricted seat travel 16
 - seatbelts 192
 - safety 27
 - warning lamp 27, 55
 - sitting correctly 16
- Security 11
 - alarm 176
 - perimeter 11
 - deactivating the alarm 13
 - steering column lock 78
- Selecting valet mode 117
- Service information
 - airbags 37
- Service interval indicator 59
- Servicing
 - data recording 231
 - interval indicator 59
- Setting a destination (navigation) 157
- Setting cruise speed 96
- Settings
 - rear media 116
 - telephone 152
- Side lights
 - warning lamp 56
- Silencing the alarm 13
- Sitting correctly 16
- Smart key
 - battery changing 10

Index

- Driving position memory 17
 - single locking 11
 - transmitters 206
 - Snow chains 213
 - Specifications
 - brake pedal travel 205
 - dimensions 203
 - engine 200
 - engine oil 195
 - ethanol 170
 - fluids 200
 - washer 198
 - fuel 173
 - Fuel tank capacity 173
 - label locations 232
 - lubricants 200
 - methanol 170
 - weight 202
 - wheel alignment 205
 - Speed-dependent wipers 43
 - Split screen map 156
 - SRS
 - Airbags 176
 - SRS (Supplementary restraint system)
 - airbag covers 192
 - airbag deployment 37
 - airbag warning lamp 37, 56
 - child seat check list 29
 - child seat positioning 29
 - child seats 28
 - ISOFIX Anchor points 31
 - seatbelts (beltminder) warning lamp . . . 55
 - Stability control
 - switching off 85
 - switching on 85
 - warning lamps 85
 - Starting
 - preparation 231
 - Starting navigation guidance 157
 - Starting the engine
 - diesel engine 78
 - petrol engine 78
 - Steering column lock 78
 - Steering wheel
 - adjusting 24
 - column lock 78
 - controls
 - connect phone call 151
 - decrease volume 151
 - disconnect phone call 151
 - increase volume 151
 - scroll/search down 151
 - set cruise speed 96
 - voice control talk 151
 - Steering wheel controls 151
 - Storage compartments 65
 - cup holders 65
 - front cubby box 65
 - glove box 65
 - rear armrest 65
 - Sunroof
 - reset 190
 - Switching off the engine 79
 - Switching on the engine
 - diesel engine 78
 - petrol engine 78
 - Switching on the ignition 78
- ## T
- Technical specifications
 - weights 202
 - wheel alignment 205
 - Telephone
 - bluetooth 148
 - call volume 151
 - changing the connected telephone 150
 - compatibility 148
 - controls
 - steering wheel 151
 - dialling 151
 - icons 150
 - last 10 152
 - overview 147
 - pairing 149
 - phonebook 151

- safety 148
- settings 152
- Television
 - analogue/digital option 137
 - controls 136
 - full screen 137
 - controls 137
- TMC (Traffic message channel) 163
 - display 161
 - overview 161
- TMC (Traffice message channel)
 - icons 161
- Touch screen 192
 - CD
 - controls 128
 - climate control
 - front 60
 - controls 140
 - display icons 116
 - home menu 115
 - navigation
 - all softkey 161
 - coordinates 159
 - list 161
 - menu 154
 - motorway 160
 - POI categories 160
 - POI (Points of interest) 158, 160
 - postcode 159
 - screen modes 156
 - search area 157
 - TMC 161
 - TMC display 161
 - TMC icons 161
 - operating 116
 - portable media
 - automatic reconnection 135
 - changing device 135
 - connecting devices 130
 - connecting multiple devices 134
 - connections 130
 - controls 132
 - lost connection 135
 - pairing 134
 - playing 133
 - RSE (Rear seat entertainment)
 - controls 140
 - screen settings 116
 - settings 140
 - setup 116
 - system settings 116
 - telephone
 - last 10 152
 - pairing 149
 - phonebook 151
 - television
 - analogue/digital option 137
 - controls 136
 - full screen 137
 - full screen controls 137
 - touch screen care 116
 - valet mode 117
 - video media player
 - controls 138
- Tow eye (front) 228
- Towing eyes 228
- TPMS (Tyre pressure monitoring system) . 92
 - tyre care 211
 - valves 212
 - warning lamp 57
- tracDSC
 - warning lamps 85
- Traction control
 - switching off 85
 - switching on 85
 - warning lamps 85
- Traffic event icons 162
- Transmission (automatic) 81
- Transmitters
 - smart key 206
- Trim
 - airbag covers (cleaning) 192
- Trip computer 58
 - change display 58
 - range 59

- Turning on the engine
 - diesel engine 78
 - petrol engine 78
- TV
 - analogue/digital option 137
 - controls 136
 - full screen 137
 - controls 137
- Tyre pressure checking 211
- Tyre pressure checking after repair 168
- Tyre repair kit
 - repair procedure 167
- Tyres
 - age degradation 212
 - flat spots 212
 - pressures 211
 - punctured 212
 - repair kit 165, 167
 - repair procedure 167
 - safety 165
 - replacements 212
 - snow chains 213
 - TPMS (Tyre pressure monitoring system) 92
 - warning lamp 57
 - tyre care 211
 - valves 212
 - winter 212
- U**
 - Unlocking 5, 12
 - entry and exit mode 24
 - global opening 8
 - keyless entry 8
 - Urban cycle 175
 - Used engine oil 178
 - Using cruise control 96
 - Using rear seat entertainment 142
 - Using the parking aid 94
- V**
 - Valet mode 117
 - deselecting 117
 - Vehicle alarm 176
 - Vehicle battery
 - removing 209
 - Vehicle battery care 207
 - Vehicle cleaning
 - exterior 190
 - interior 191
 - parking sensors 95
 - Vehicle data recording 231
 - Vehicle recovery
 - attaching the front tow eye 228
 - towing eyes 228
 - Vehicle settings
 - valet mode 117
 - Video
 - headphones 142
 - loading DVDs 139
 - touch screen controls 140
 - Video media player
 - controls 138
 - inhibited playback 139
 - VIN number 232
 - Voice control 144
 - navigation POI 145
 - training 145
 - tutorial 145
 - voicetags 145
 - Voice guidance 158
 - Volume
 - telephone 151
- W**
 - Warning lamps 54
 - ABS 56
 - adaptive front lighting system 56
 - AFS 56
 - airbags 37, 56
 - beltminder 55
 - brake 54

- brakes 89
 - Critical warning message 54
 - DSC 55
 - fog lamps 56
 - headlamp high beam 56
 - indicators 56
 - lamp test 54
 - parking brake 54
 - seatbelt 27, 55
 - side lights 56
 - TPMS (Tyre pressure monitoring system) 57
 - warning lamps
 - stability control 85
 - Warning messages 58
 - Warning symbols (battery) 207
 - Warranty 164
 - Washer jets
 - blockages 181
 - Washers
 - operating 43
 - Washers (headlamps) 44
 - Water in fuel 173
 - Weekly checks 176
 - Weights 202
 - Wheels and tyres
 - accessory 205
 - age degradation 212
 - checking the pressures 211
 - checking the pressures after a repair 168
 - flat spots 212
 - pressures 211
 - puncture repair 165
 - safety 165
 - punctured 212
 - repair kit 165, 167
 - repair procedure 167
 - safety 165
 - replacements 212
 - snow chains 213
 - TPMS (Tyre pressure monitoring system) 92
 - warning lamp 57
 - tyre care 211
 - tyre label 232
 - valves 212
 - wheel alignment 205
 - winter tyres 212
 - Windows 45
 - anti-trap protection 46
 - one-touch operation 46
 - reset 190
 - sunroof
 - reset 190
 - Windscreen wipers
 - speed-dependent mode 43
 - Windscreens (heated) 61
 - Wipers
 - operating 43
 - Wipers and washers
 - fluid
 - specification 198
 - top up 198
 - operating 43
 - rain sensor 44
 - wipers
 - speed-dependent mode 43
- X**
- Xenon headlamps 183

DRIVER CONTROLS

1. Map reading lamp switch (42).
2. Main interior lamp switch (42).
3. Sunroof close switch (45).
4. Sunroof open switch (45).
5. High beam/Direction indicator/Trip computer switch (38/58).
6. Gearshift paddle (81).
7. Audio system control:
 - Standard system, (104).
 - Touchscreen system, (119).
8. Instrument pack and message centre (52/54).
9. Vehicle information menu control (52).
10. Wiper/washer controls (43).
11. START/STOP button (78).
12. Audio system and controls (119).
13. Display/touch screen (115).
14. Left hand heated seat switch (60).
15. Stability control off switch (85).
16. Hazard warning light control switch.
17. Parking aid switch (94).
18. Right hand heated seat switch (60).
19. Heater/air conditioning controls (60).
20. Gear selector lever - 6 speed transmission (81).
21. Transfer gearbox switch - 8 speed transmission (83).
22. Hill descent control (HDC) switch (102).
23. Air suspension control (86).
24. Terrain response control (99).
25. Rotary gear selector - 8 speed transmission (81).
26. Electric parking brake (90).
27. Heated steering wheel switch (24).
28. Voice recognition and telephone switches (144/151).
29. Horn switches.
30. Cruise control switches (96).
31. Electric mirror controls (47).
32. Electric window controls (45).
33. Electric window rear isolator switch (45).
34. Rear fog lamp switch (38).
35. Front fog lamp switch (38).
36. Headlamp levelling control (Halogen lamps) (41).
37. Instrument illumination dimmer control (38).
38. Main exterior lamp control (38).

