

Dual Mass Flywheel (DMF)

The purpose of the DMF is to provide torsional isolation via a spring damping system.

A DMF helps to improve poor vehicle noise and vibration such as, gear rattle, body boom and load change vibration.

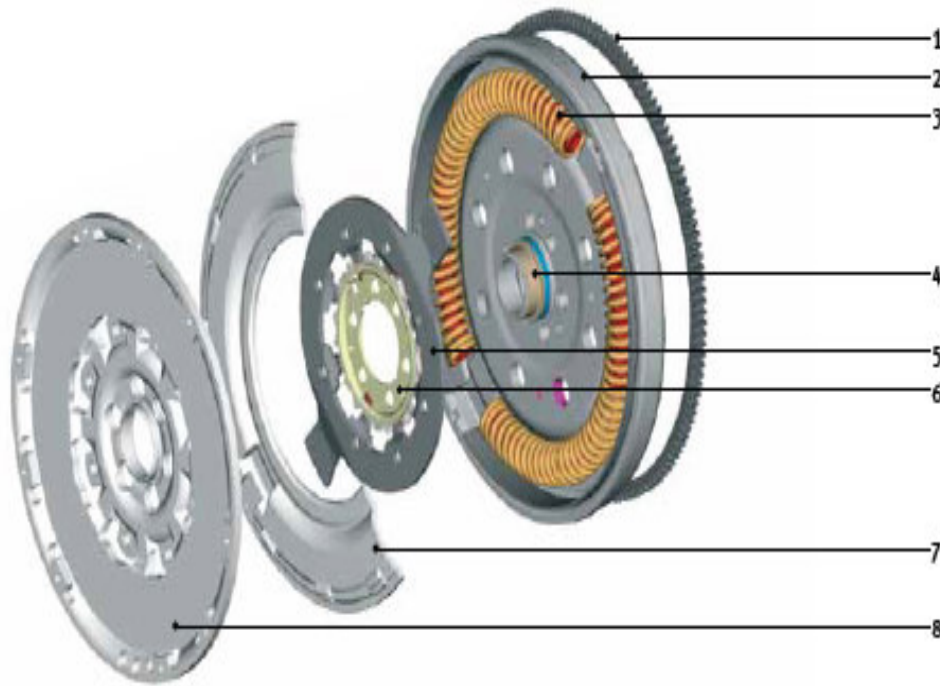

- 1 Starter ring gear
- 2 Primary flywheel
- 3 Arc springs
- 4 Plain bearing

- 5 Flange
- 6 Floating friction device
- 7 Primary cover (cross section)
- 8 Secondary flywheel

Common fault mis-diagnosis

Heat damage- Not assessed against criteria. (see [visual thermal diagnosis](#))

Not checking operating angle correctly.

Hard contact to one side – Friction control plate is not centralised.

Axial rock- Some rock will always be present & this will increase with wear

Noise when checking / rotating secondary – Noise from springs may be heard but this needs to be assessed with how freely the parts move.

Clutch surface damage wrongly diagnosed.

DMF- Checking Process

*DMF with Internal Torque Limiter (ITL):

Depending on the relative position of ITL device and secondary mass it may be necessary to centre the ITL before checking the operating angle.

Rotate the secondary mass in both directions by hand (Pic 1), you should feel spring resistance in each direction.

If spring resistance can't be felt in both directions rotate the secondary mass WITH FORCE using a suitable lever but only in the direction where the hard stop was felt rather than spring resistance (Pic 2).

Re check & repeat if necessary.

Once you feel spring resistance in both directions follow instructions for checking **operating angle in vehicle**.

Pic 1

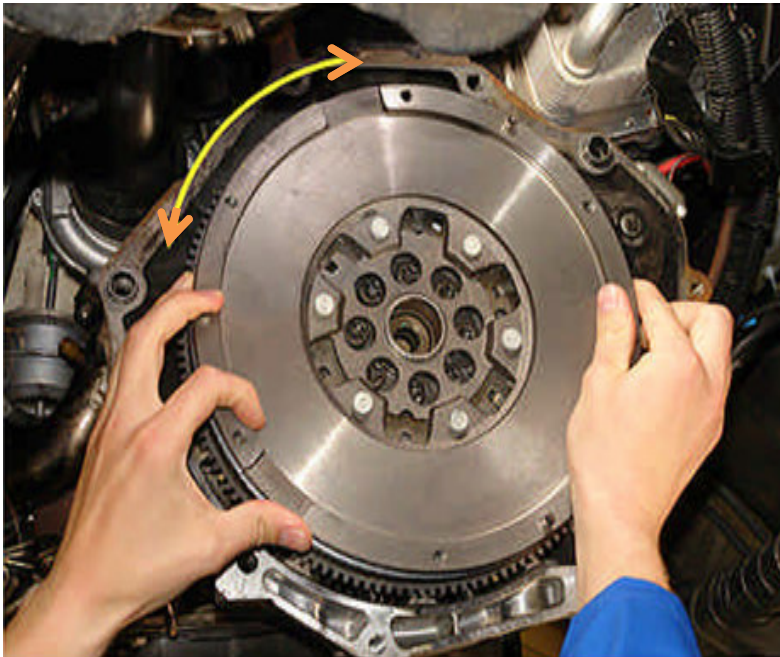

Pic 2

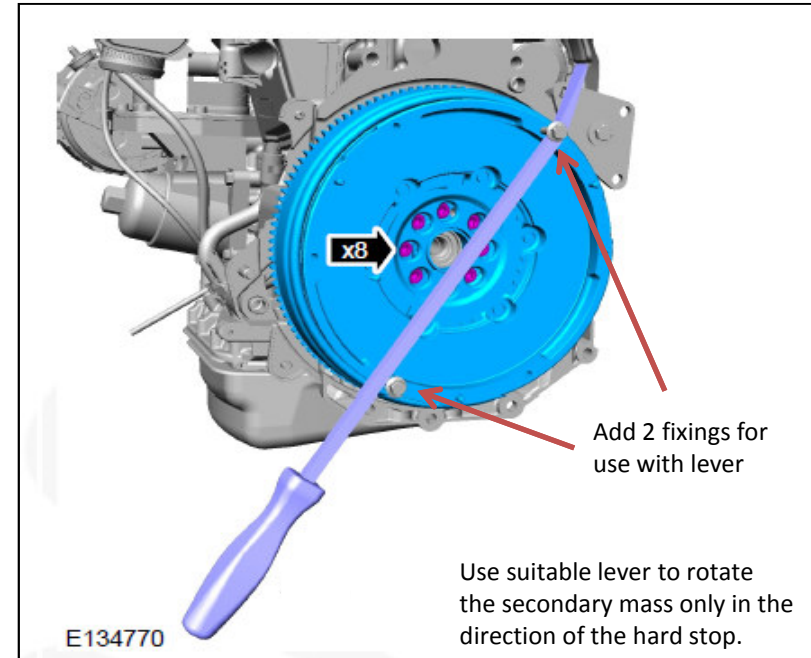

Measurement of operating angle in vehicle

Before performing the operating angle test the DMF should be rotated slowly as far as possible clockwise & anticlockwise. This allows you to get good feel for the spring resistance force, if unusually loud clacking, grating or rasping sounds occur this indicates damage in the DMF

Measurement of operating angle in vehicle

NOTE: All DMF's have an operating angle

1. Rotate the secondary flywheel **clockwise** until the spring resistance can be felt (Pic 1)
2. Slowly release the flywheel until the arc spring is relaxed i.e. the point at which no more spring resistance can be felt
3. Clearly mark the position of the secondary flywheel **and the ring gear** with a white pen using a vertical line (Pic 2)
4. Now rotate the secondary flywheel **anticlockwise** until spring resistance can be felt
5. Slowly release the flywheel until the arc spring is relaxed i.e. no more spring resistance can be felt.
6. Mark the ring gear position adjacent to the previous mark on the secondary flywheel made at step 3 with a white pen using a vertical line (Pic 3)
7. Count the number of starter ring gear teeth from paint mark to paint mark. (Pic 4)

NOTE- The maximum allowed number of teeth at the ring gear when determining free play for Land Rover Discovery 3 and 4, Freelander 2 and Range Rover Evoque is 6 teeth. Flywheels should not be replaced unless the movement is outside of this parameter.



Pic 1



Pic 2

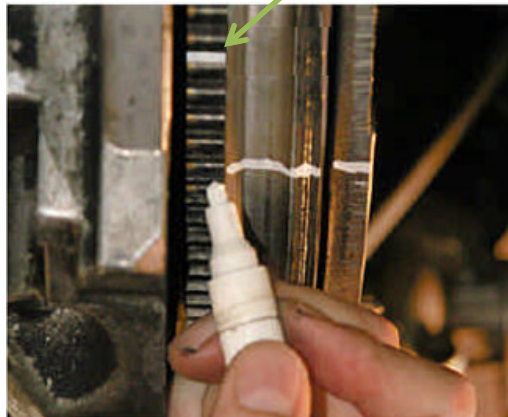

Pic 3

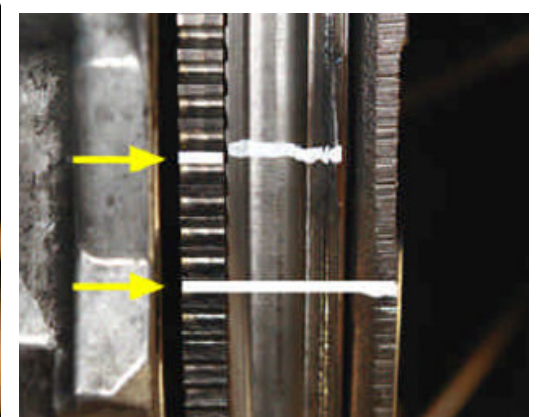

Pic 4

DMF: Visual aid for diagnosis of thermal issues

9. Low thermal load

Description

- Friction surface slightly discoloured (gold/yellow)
- No tarnish at the outer edges of the DMF or in the rivet area

Cause

- Thermal load

Effect

- None

Remedy

- No remedial measures required



10. Moderate thermal load

Description

- Friction surface discoloured blue due to temporary thermal load (220 °C)
- No discolouration in the rivet area

Cause

- Discolouration of the friction surface is a normal occurrence during operation

Effect

- None

Remedy

- No remedial measures required



DMF: Visual aid for diagnosis of thermal issues

11. High thermal load

Description

- Tarnish in rivet area and/or at the outer diameter; no tarnish on the friction surface
- The DMF was in continued operation after high thermal load had occurred

Cause

- High thermal load (280 °C)

Effect

- Depending on the duration of the thermal load applied, the DMF may become defective

Remedy

- Replace DMF

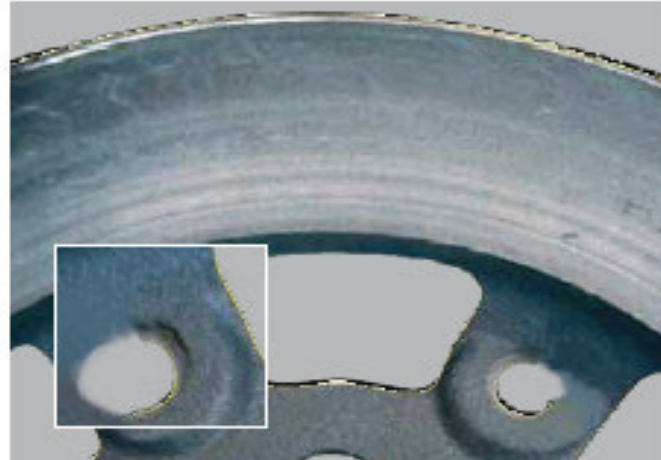

12. Very high thermal load

Description

- DMF discoloured blue/purple at the side or on the back and/or is visibly damaged, e.g. cracks

Cause

- Very high thermal load

Effect

- DMF is defective

Remedy

- Replace DMF

